



# ALLWEILER PROGRESSING CAVITY PUMP AEB-DE DOSING PUMP SERIES

FOUR PUMP SIZES  
ONE INSTALLATION FOOTPRINT



**SPACE-SAVING MODULAR DESIGN**  
**CUSTOMIZABLE WITH SELECTED ROTOR AND STATOR**  
**CAPABLE OF BI-DIRECTIONAL FLOW**

## A NEW ALLWEILER TRADITION FOR FLEXIBLE INSTALLATION

---



Metering and dosing of high viscosity and particulate-filled fluids requires a progressing cavity pump that can achieve high efficiency and failure-free operation. Today, however, pump skid builders and their customers need and expect more than stable pump performance and accurate dosing capabilities. They look for pump suppliers that can offer traditional quality and reliability solutions but also combine them with cost-effective pricing and reasonable delivery times. All of this can be found in the next-generation ALLWEILER AEB-DE dosing pump series. We have combined proven and long lasting features from our trusted industrial pump range with optimized rotor and stator geometries for the utmost in accurate metering. But the added value this new series offers sets a new bar for flexible installation.

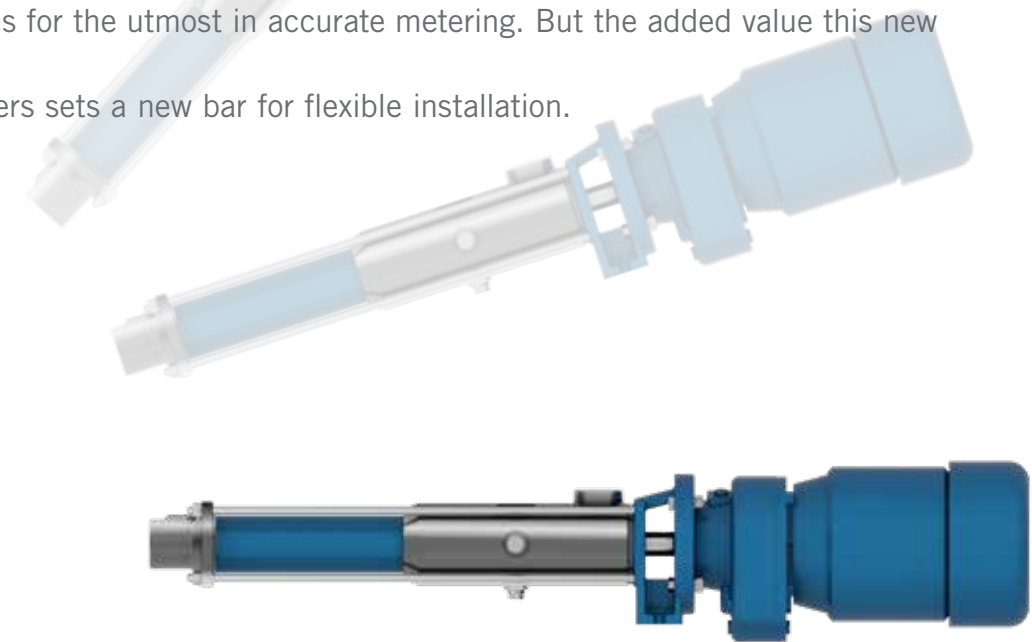



# FOUR PUMP SIZES. ONE INSTALLATION FOOTPRINT.

The modular setup of the AEB-DE series makes it simple for skid builders to standardize their designs without regard to flow rate and liquid characteristics. A compact modular design adapts to skids with ease. Skid builders simply outfit the installation space for the specified pump according to the operating data provided. Four pump sizes with identical outside dimensions are available to suit user needs and are capable of bi-directional flow. This flexibility facilitates future variations in needed flow rates with simple changeouts of conveying elements. No cost-intensive refurbishments or adjustments to piping are necessary.

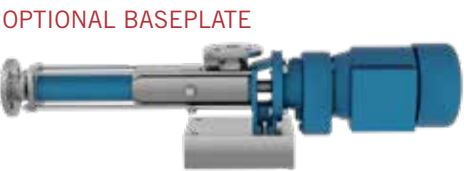
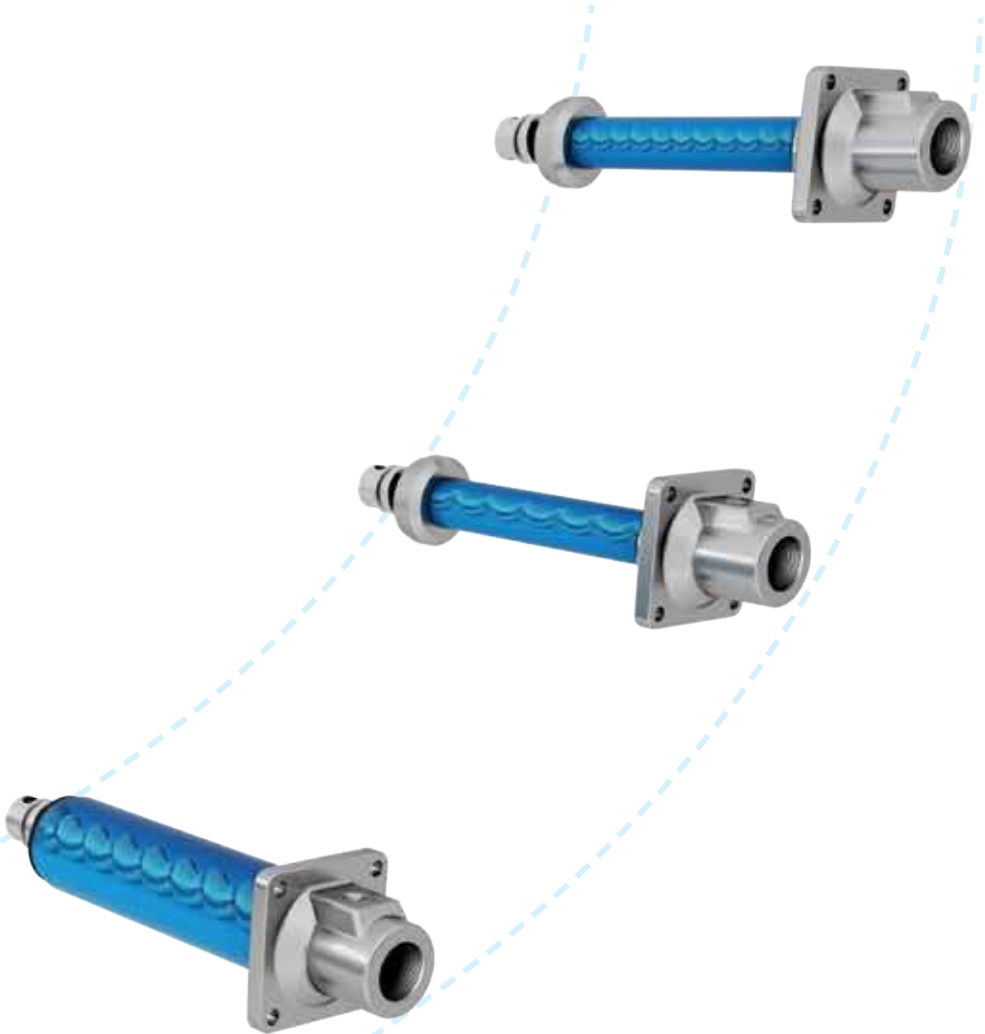
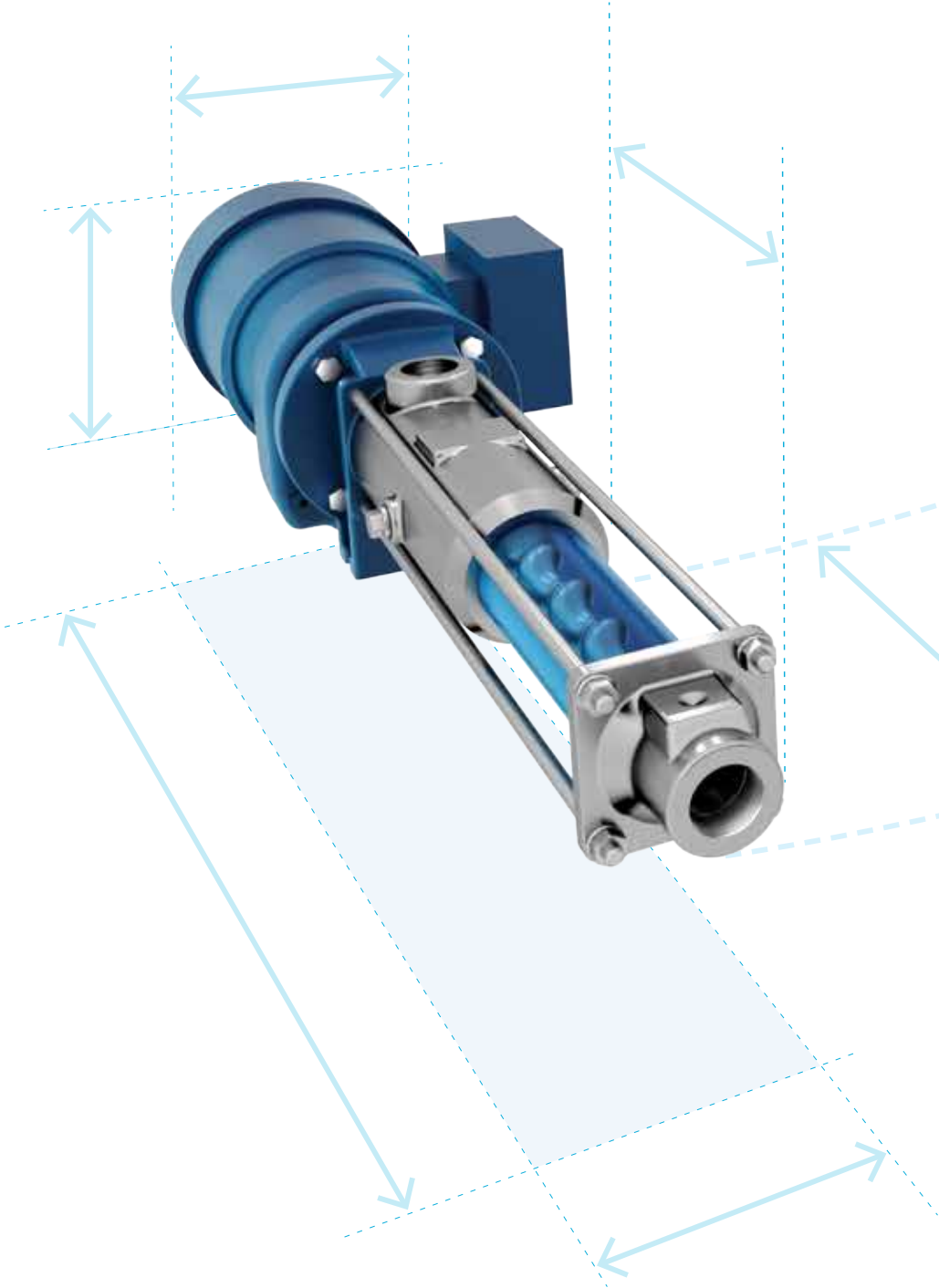

Users have a choice between threaded and flanged pump connections with an optional baseplate.

## OPTIMIZED FOR SAFETY AND UPTIME

The innovative design of the new suction casing has three additional closed drillings that can be used for various functions. Customers have the ability to fill the pump, to drain it, or to install additional auxiliaries if needed. Further, the new design of the casing ensures a permanent flushing and cooling of the seal as it is located in the flow of liquid. Due to this, the pump can also be installed vertically without any risk of harmful dry run. (If required, a quench connection can be offered as a seal option or the pump can be equipped with a gland packing.) To further ensure safe plant operation and preventable breakdowns or damage to the pump, the AEB-DE series can be upgraded with smart dry running protection (ATLS-T1) or a pressure sensor (ATLS-P).

**SAFE & SMART – DRY-RUNNING PROTECTION**  
A dry running protection prevents catastrophic breakdowns and downtime by detecting dry-running.

**SAFE & SMART – MONITORING**  
The pressure transmitter monitors the pressure and the provided signal can be used to increase plant safety, preventing overpressures and damages to the pump and piping.

**EXCELLENT PERFORMANCE**  
Optimized rotor and stator geometries for high efficiency and accurate metering capabilities

**ENGINEERED TO LAST**  
Proven and robust industrial joint design with exchangeable & hardened wear parts. Supplemented by using special joint oil the design results in long lifetime and less downtime.

**FLEXIBLE INSTALLATION**  
Choose between threaded and flanged connections, without any risk of seal failure and dry run.

**CONFIGURED TO COMPLY WITH CUSTOMER NEEDS**  
The geared motor is selected and configured to the best fit for every application. Optional VFDs and can be provided on top of the motor terminal box for speed & flow adjustments.

**SEALING OPTIONS**  
The standard mechanical seal also has a quench connection option. Or a stuffing box with a gland seal may be selected. As the seal is in the liquid flow the pump can be installed either horizontally or vertically without any risk of seal failure and dry run.

**AUXILIARY CONNECTION**  
Suction casing can be rotated by 90° for further flexibility. With three drillings the drainage of the pump is assured.

**OPTIONAL BASEPLATE**  
A baseplate can be provided if required.

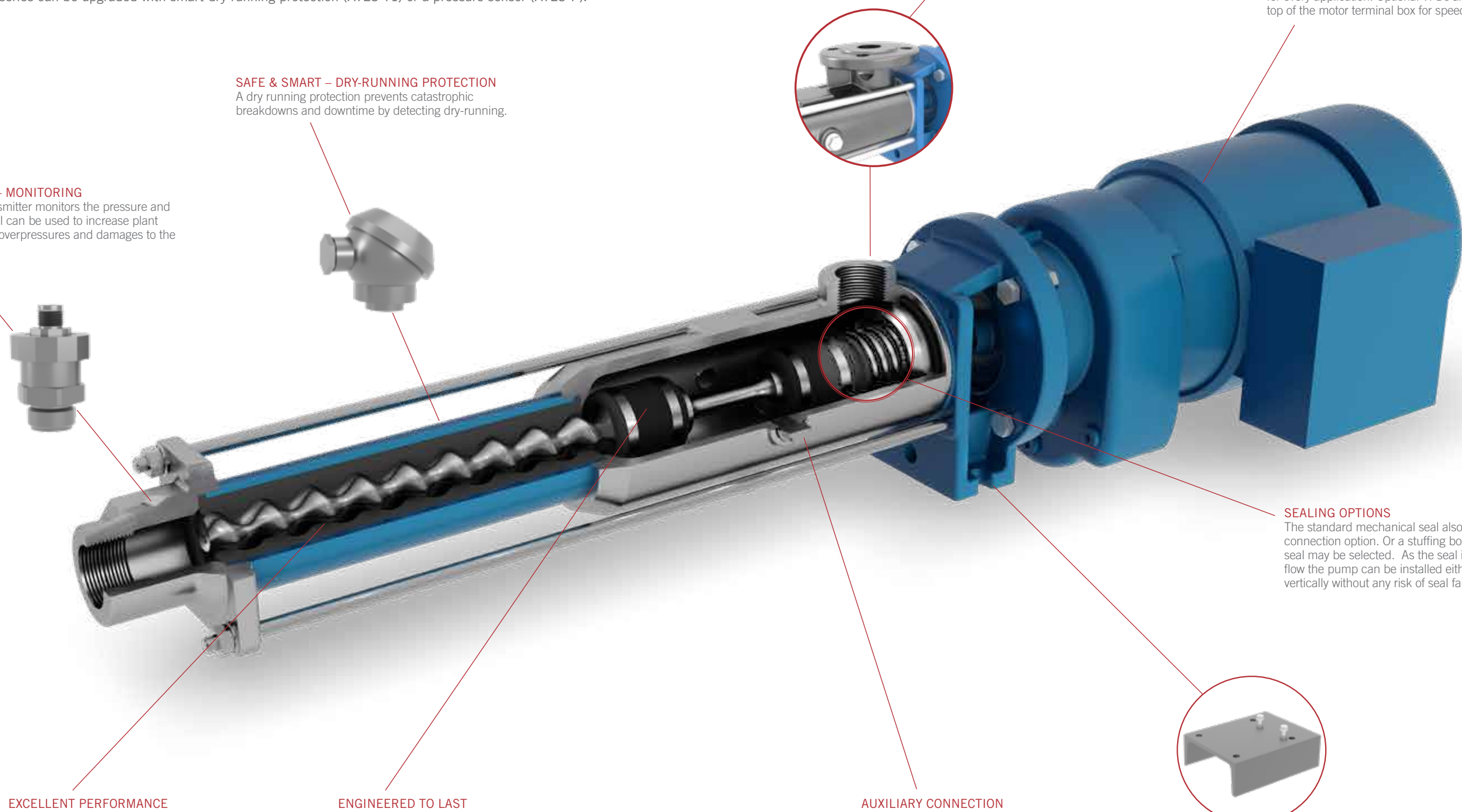

## ONE PUMP SERIES FOR MORE OF YOUR DOSING APPLICATIONS

Versatile and compact, the AEB-DE pump series accommodates wide viscosity, flow rate and temperature ranges and delivers reliable high volumetric efficiency. The geared motor is selected and configured to the best fit for every application. Optional VFDs can be provided on top of the motor terminal box for speed and flow adjustments. The geometry and technical details of key components have been optimized to further improve metering accuracy and performance curve stability. High-grade stainless steel material allows pumps to cover even more applications than before, including:



### WATER & WASTEWATER

Polymer, Flocculant



### PULP & PAPER

Additives, PVOH, Sizing Agent, Starch, Dye, Optical Brightening Agent, Polymer



### MARINE

Oily water, Urea, Bilge, Seawater



### GENERAL INDUSTRY

Caustic Soda, Glycol, Paints, Glues, Sealants



### CHEMICAL PROCESS INDUSTRY

Acid, Leachate, Catalysts, Condensate, Additives



### MINING

Polymer, Tenside, Catalyst



### FOOD

Oil, Sauce, Chocolate, Liquor



### POWER

Urea, Waste Oil, Slop Oil



# EASY TO SELECT PERFORMANCE DATA

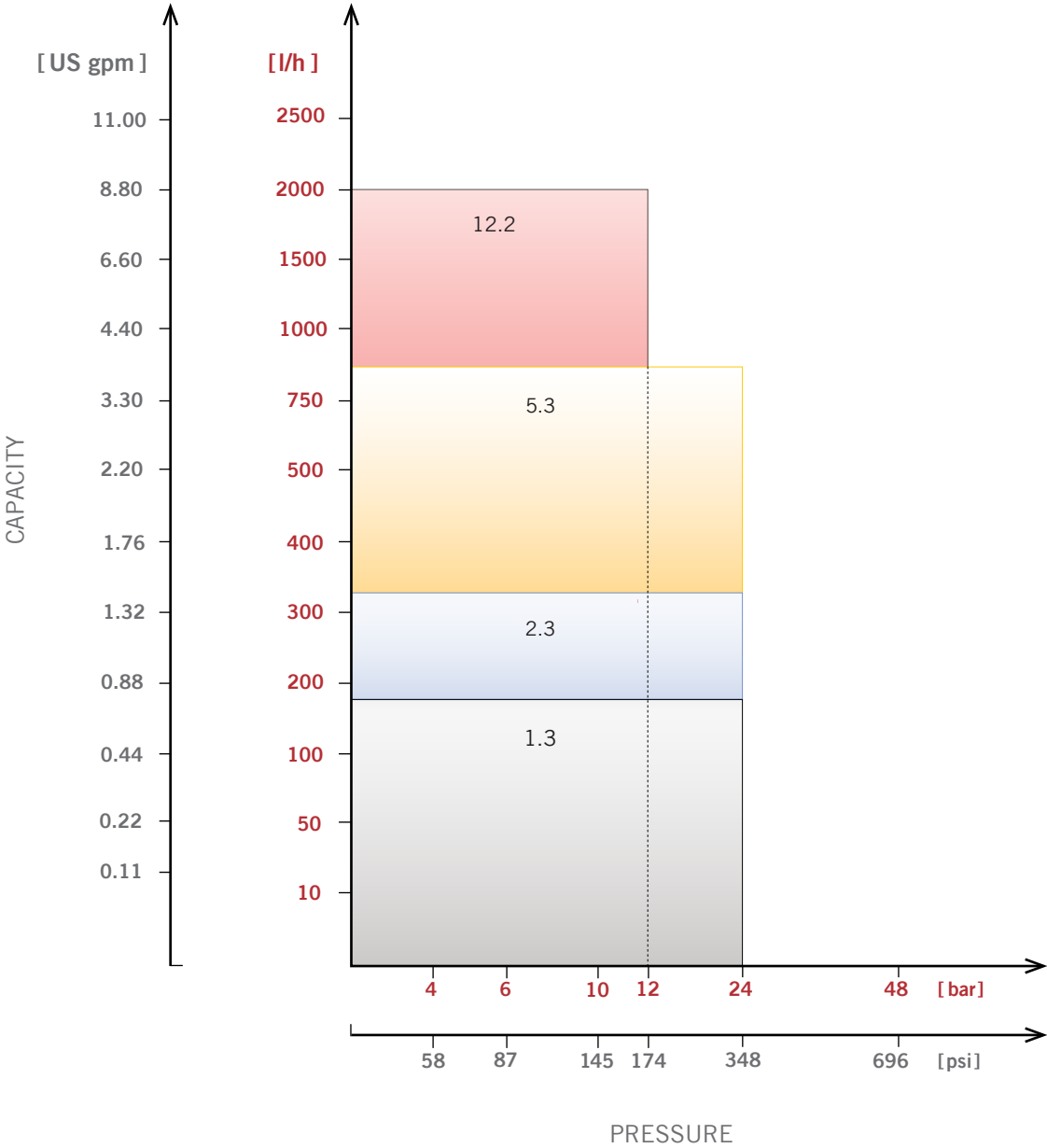

PERFORMANCE DATA			
<b>CAPACITY</b>	Q	UP TO	33 l/min / 8,7 GPM
<b>DIFFERENTIAL PRESSURE</b>	$\Delta P$	UP TO	24 bar / 348 PSI*
<b>ACHIEVABLE UNDERPRESSURE</b>	P <sub>s</sub>	UP TO	0,9 bar / 13 PSI
<b>OUTLET PRESSURE</b>	P <sub>d</sub>	UP TO	25 bar / 363 PSI
<b>LIQUID TEMPERATURE</b>	t	UP TO	100 °C / 212°F
<b>LIQUID VISCOSITY</b>	$\nu$	UP TO	28.000 mPas
<b>PERMISSIBLE PROPORTION OF SOLIDS</b>	vol %	UP TO	60

\* Pump size 12.2 limited to 12 bar / 174 PSI

# TECHNICAL INFORMATION AND OPTIONS

## SECTIONAL VIEW

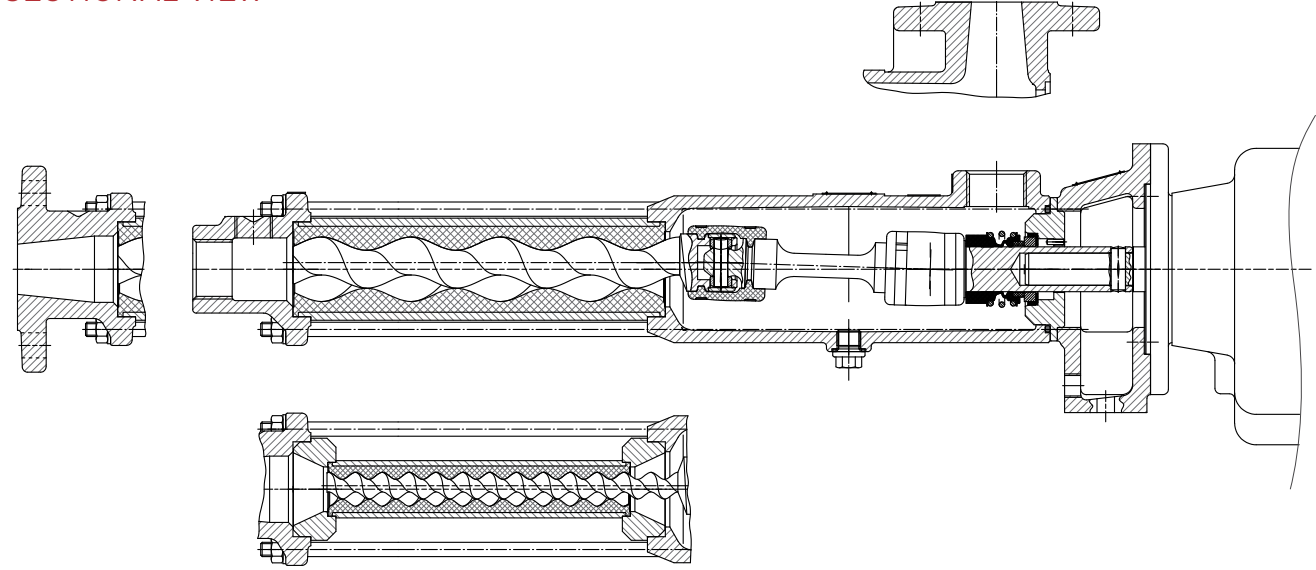

## SEALING

The standard single acting non balanced mechanical seal is also available with a quench.

Alternatively the pump can be equipped with a stuffing box.

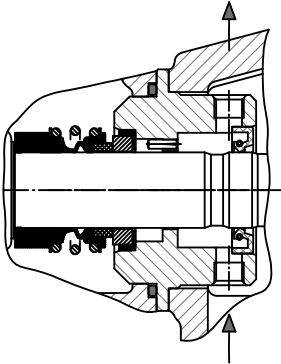

Permitted pressure at shaft seal  
 P= -0,5 to 12 bar (16 bar) / -7,3 PSI to 174 PSI (232 PSI)

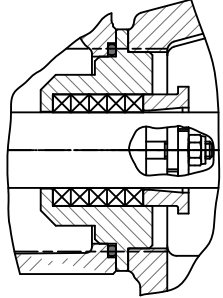

Permitted pressure at shaft seal  
 P= -0,7 to 16 bar / -10,2 to 232 PSI



CIRCOR is a market-leading, global provider of integrated flow control solutions, specializing in the manufacture of highly engineered valves, instrumentation, pumps, pipeline products and services, and associated products, for critical and severe service applications in the oil and gas, power generation, industrial, process, maritime, aerospace, and defense industries.

## Excellence in Flow Control

Asia | Europe | Middle East | North America | South America

ALLWEILER GmbH  
Allweilerstr. 1  
78315 Radolfzell  
Germany  
Tel.: +49 7732 86 0

ALLWEILER GmbH  
Kirchhellener Ring 77-79  
46244 Bottrop  
Germany  
Tel.: +49 2045 966 60

CIRCOR Monroe  
1710 Airport Rd  
Monroe, NC 28110  
USA  
Tel.: 1-704-289-6511

CIRCOR Shanghai  
Unit 804, Venture International Park  
Building B No. 2679  
Hechuan Road  
Shanghai 201103 China  
Tel.: +86 21 6248 1395



[circorpt.com/allweiler-pc](http://circorpt.com/allweiler-pc)

CIRCOR and ALLWEILER are registered trademarks of CIRCOR International or its subsidiaries in the U.S. and/or other countries. ©2020, CIRCOR International. All rights reserved. GB-IND029-AEBDE-02/2020