

EMTEC®-C PUMPEN FÜR HOCHDRUCK-KÜHLMITTELVERSORGUNG

KÜHLMITTELPUMPEN AUF HÖCHSTEM LEISTUNGSNIVEAU

LÄNGERE LEBENSDAUER.
HÖHERE EFFIZIENZ.
NIEDRIGERE PULSATION.

PUMPEN SIE LEBEN IN IHRE KRITISCHSTE ANLAGE

EMTEC-C KÜHLMITTELPUMPEN VERLÄNGERN DIE LEBENSDAUER IHRES SYSTEMS WESENTLICH

Entwickelt um Ihre Anlage effizient zu kühlen und zu schützen, verlängert EMTEC-C die Lebensdauer und liefert gleichzeitig eine unübertroffene Zuverlässigkeit.



ANWENDUNGSBEREICHE

Die EMTEC-C wurde für die Handhabung von gut-, mittel- bis schlechtschmierenden abrasiven Medien in der Kühlschmierstoff- oder Verfahrenstechnik ausgelegt. Sie erweist sich als ein wesentliches Element in Metallbearbeitungsanwendungen, Transferstraßen und sowohl in Schleif- als auch Tiefbohrmaschinen.

EMTEC

FORTSCHRITTLICHE TECHNOLOGIE FÜR LANGE LEBENSDAUER

EMTEC-Pumpen wurden speziell für die raue Umgebung des Hochdruckkühlmittelkreislaufes in Werkzeugmaschinen ausgelegt. Spezielle Härteverfahren erzeugen in den Gehäusebohrungen eine keramikähnliche Oberflächenhärte, wobei die Elastizität beibehalten wird. Die Gefahr eines Oberflächenschadens in der Bohrung wird somit vermieden. Um eine lange Lebensdauer zu erreichen, sind die Spindeln gehärtet. Der Ausgleichskolben der Antriebsspindel ist zur Verbesserung des volumetrischen Wirkungsgrads extra lang ausgeführt. Der Flüssigkeitsstrom, der über den Ausgleichskolben fließt, dient zum Kühlen und Schmieren der Dichtflächen der Gleitringdichtung aus Siliziumkarbid.

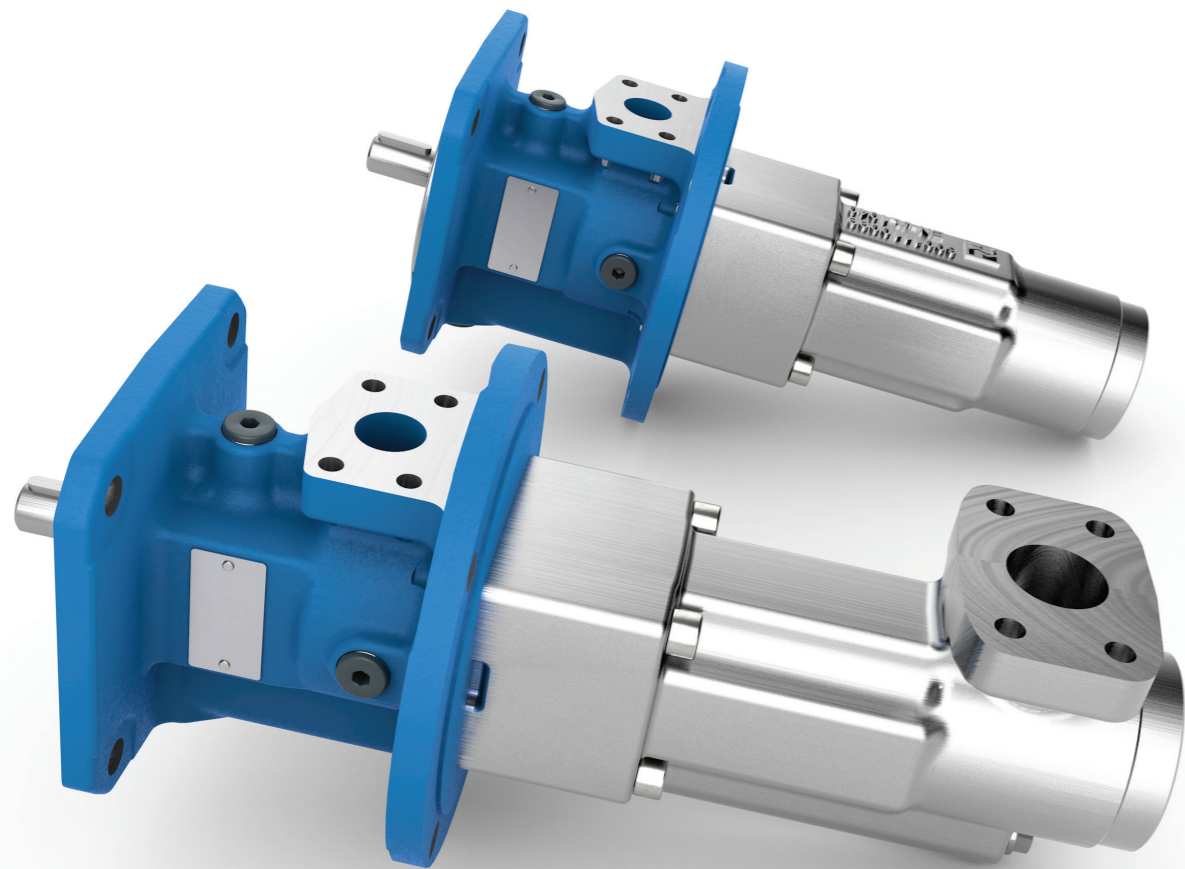

DIE NEU KONSTRUIERTE EMTEC-C

EINE JAHRZEHNTELANGE ENTWICKLUNG

Wir haben unsere beispiellose Branchenerfahrung genutzt, um die innovative EMTEC-C zu entwickeln. Die EMTEC-C ist eine wartungsfreundliche dreispindelige Schraubenspindelpumpe, die unter Verwendung einer einzigartigen Technologie aus hochwertigsten Materialien hergestellt wird und eine präzise und effiziente Leistung bei unschlagbarer Zuverlässigkeit bietet.

ÜBERSICHT BEARBEITUNGSZENTRUM

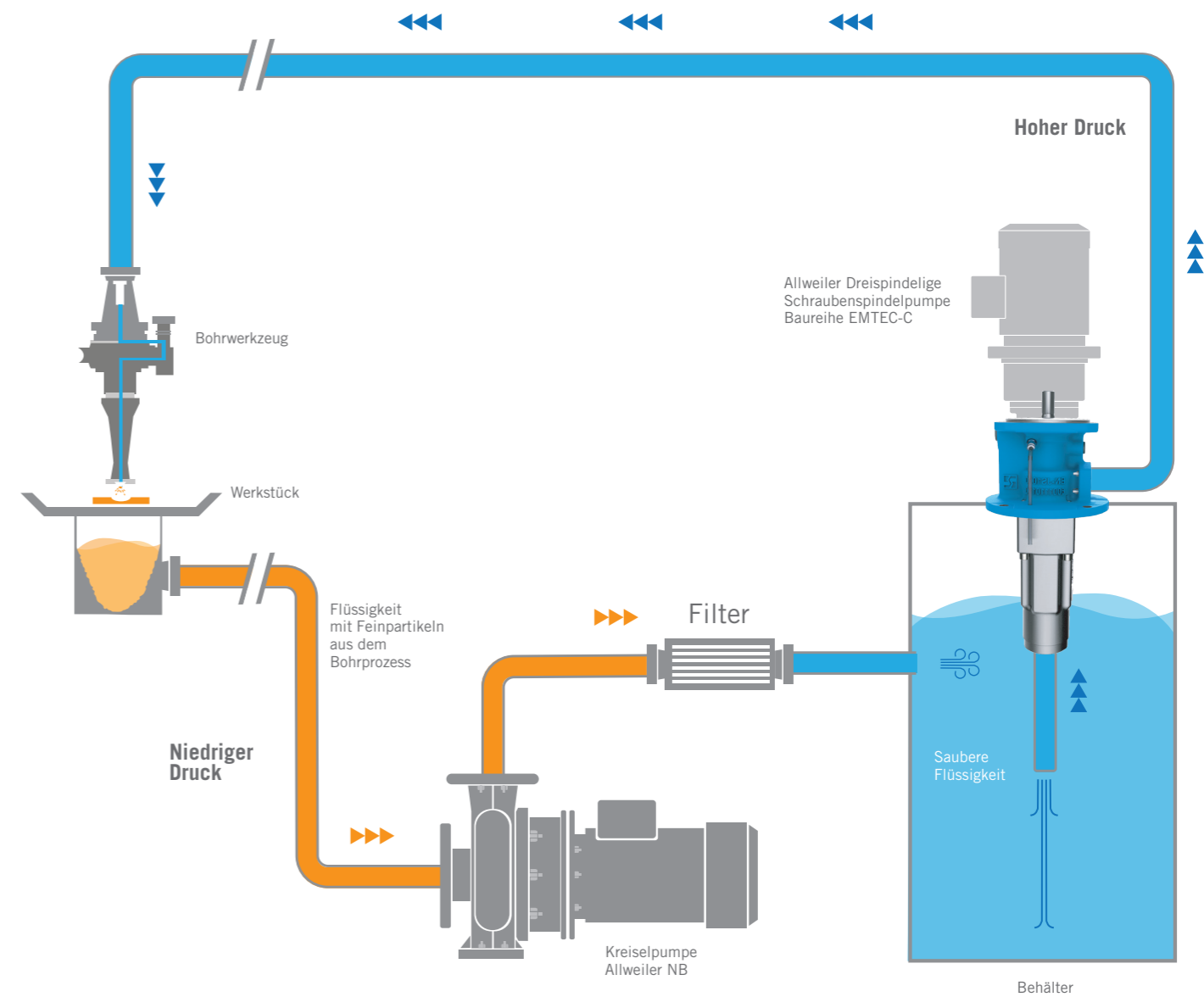

WIR MACHEN EINE GUTE PUMPE NOCH BESSER

EMTEC-C

Die robuste neue EMTEC-C wurde komplett neu konstruiert und zeichnet sich dadurch aus, dass sie Späne, Partikel und Wärme von den Schneidflächen wegbewegt und sie bietet darüber hinaus eine verbesserte Beständigkeit und erstklassige Effizienz. Die EMTEC-C ist außerdem in verschiedenen Baugrößen und Spindelsteigungswinkeln erhältlich, wodurch Kapazitätsanpassungen über den gesamten Leistungsbereich ermöglicht werden.

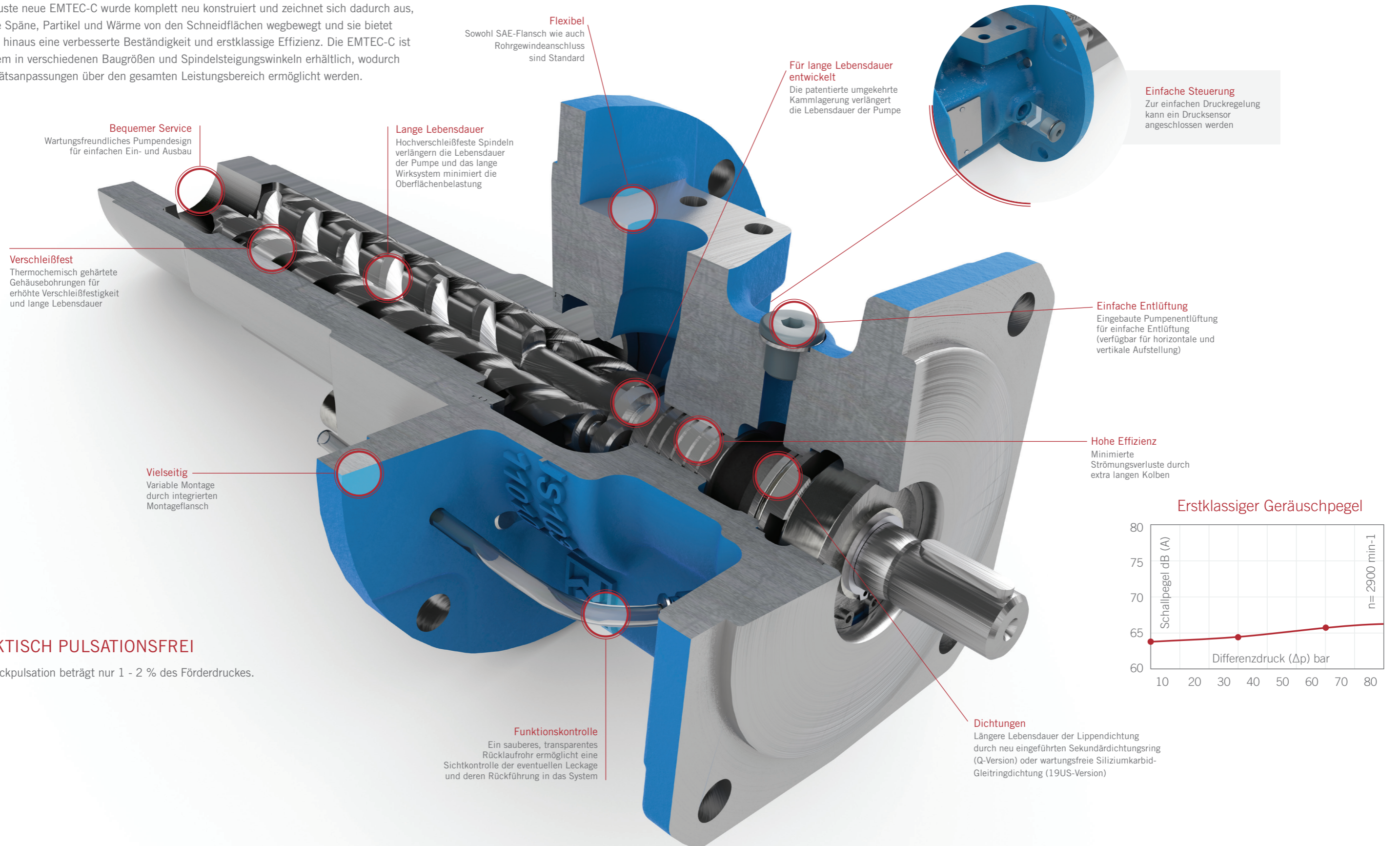

PRAKTISCH PULSATIONSFREI

Die Druckpulsation beträgt nur 1 - 2 % des Förderdruckes.

Erstklassiger Geräuschpegel

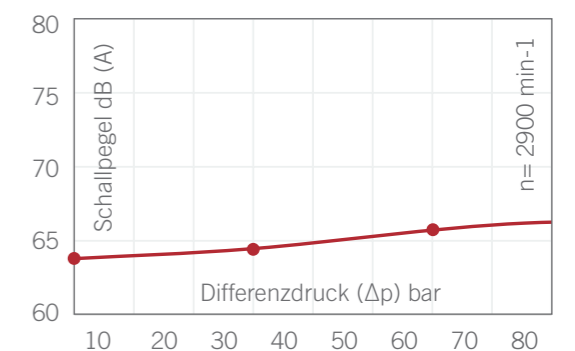

EMTEC-C RADIAL

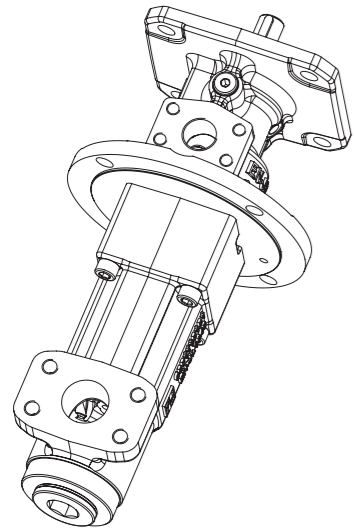

Dichtungsart	Baugröße	Steigung	Bezeichnung		
Gleitringdichtung (19US)	20	28	EMTEC-C20R28D19US-W110332		
		38	EMTEC-C20R38D19US-W110332		
		46	EMTEC-C20R46D19US-W110332		
		56	EMTEC-C20R56D19US-W110332		
	40	38	EMTEC-C40R38D19US-W110332		
		46	EMTEC-C40R46D19US-W110332		
		Wellendichtring (Q)	20	28	EMTEC-C20R28DQ-W110332
				38	EMTEC-C20R38DQ-W110332
	40	46	EMTEC-C20R46DQ-W110332		
		56	EMTEC-C20R56DQ-W110332		
	40	38	EMTEC-C40R38DQ-W110332		
		46	EMTEC-C40R46DQ-W110332		

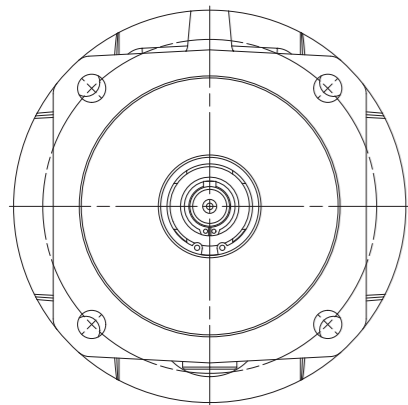
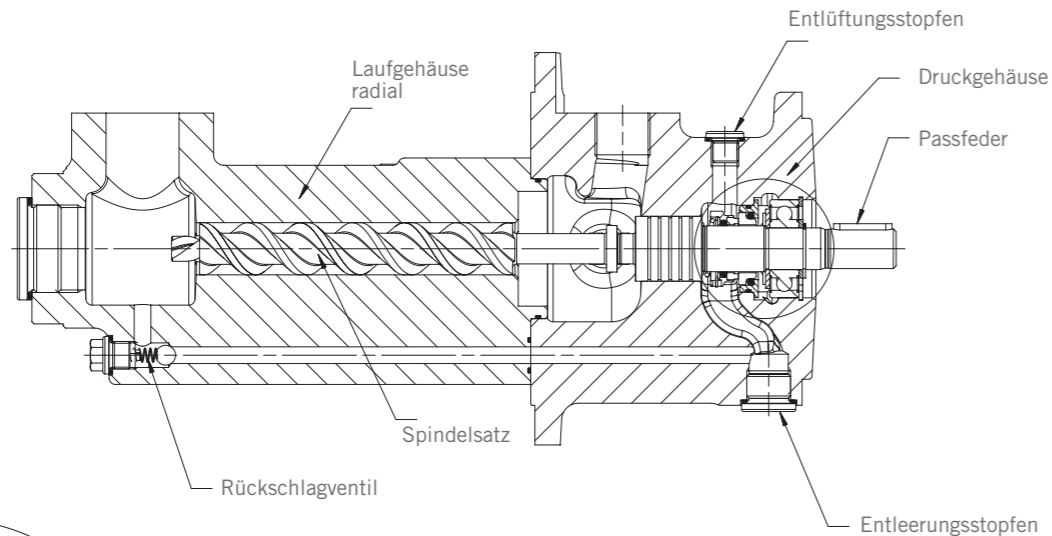

Ansicht von oben

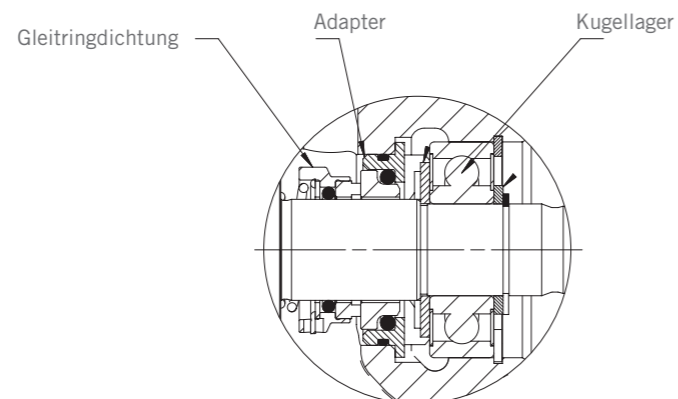

Gleitringdichtung

EMTEC-C AXIAL

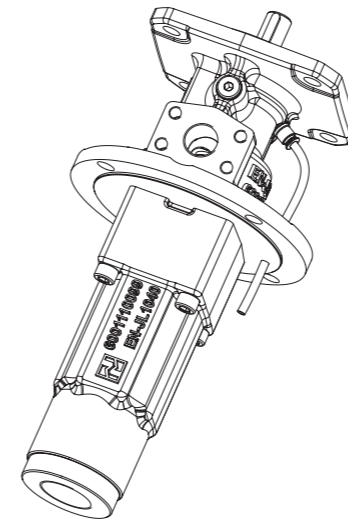

Dichtungsart	Baugröße	Steigung	Bezeichnung		
Gleitringdichtung (19US)	20	28	EMTEC-C20R28D19US-P-W110332		
		38	EMTEC-C20R38D19US-P-W110332		
		46	EMTEC-C20R46D19US-P-W110332		
		56	EMTEC-C20R56D19US-P-W110332		
	40	38	EMTEC-C40R38D19US-P-W110332		
		46	EMTEC-C40R46D19US-P-W110332		
		Wellendichtring (Q)	20	28	EMTEC-C20R28DQ-P-W110332
				38	EMTEC-C20R38DQ-P-W110332
	40	46	EMTEC-C20R46DQ-P-W110332		
		56	EMTEC-C20R56DQ-P-W110332		
	40	38	EMTEC-C40R38DQ-P-W110332		
		46	EMTEC-C40R46DQ-P-W110332		

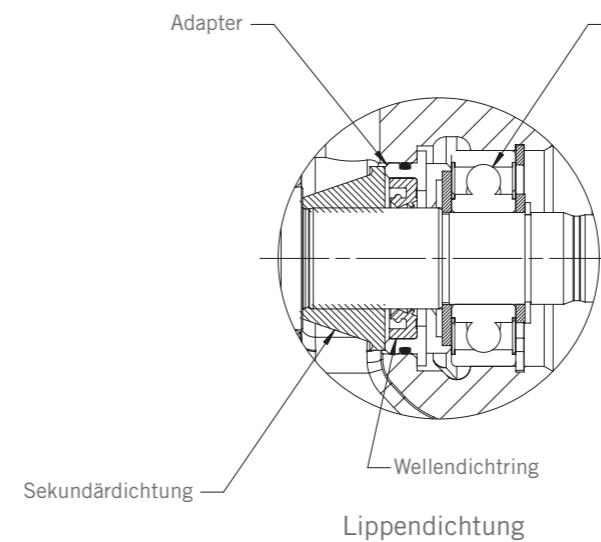
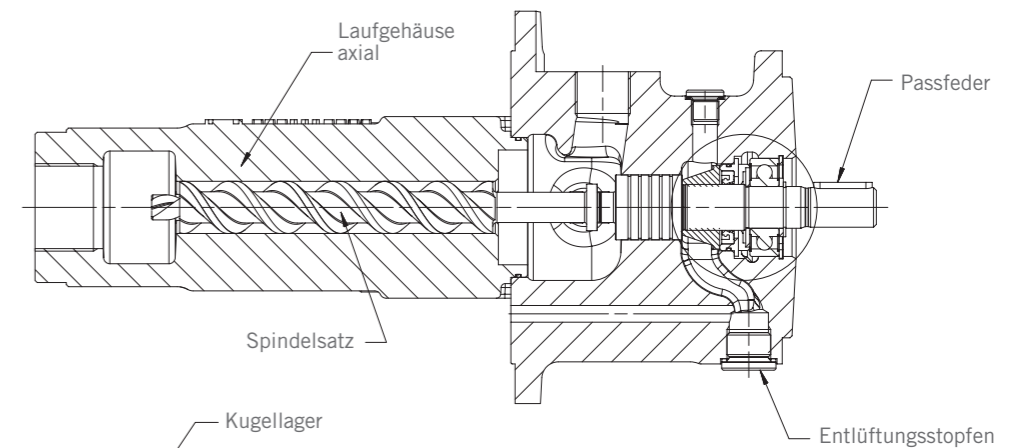

Lippendichtung

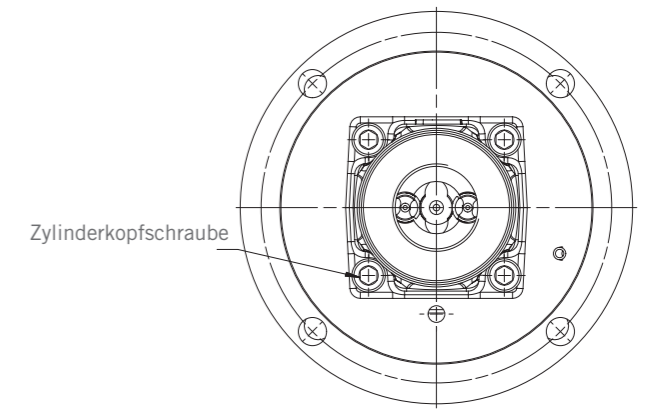

Ansicht von unten

ENTWICKELT UM JEDEN ANWENDUNGSBEDARF ZU ERFÜLLEN

In verschiedenen Baugrößen und Steigungswinkeln erhältlich und in der Lage, eine Vielzahl von Kühlschmierstoffen in einem großen Durchflussbereich zu fördern, ist die anpassungsfähige EMTEC-C genau die richtige Ausstattung für Ihren Systembedarf. Die EMTEC-C verfügt über verschiedene Aufstellungsarten, um die Anforderungen Ihrer Anwendung zu erfüllen.

Der Tankaufbau ist durch den über dem Tankdeckel liegenden Druckanschluss einfach und kostengünstig.

Der getauchte Einbau spart im Vergleich zur Trockenmontage Platz, Wartung und Kosten.

Bei der Trockenanstellung sorgt eine Gleitringdichtung aus Siliziumkarbid für eine lange Lebensdauer.

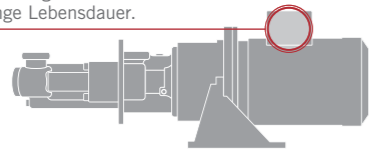
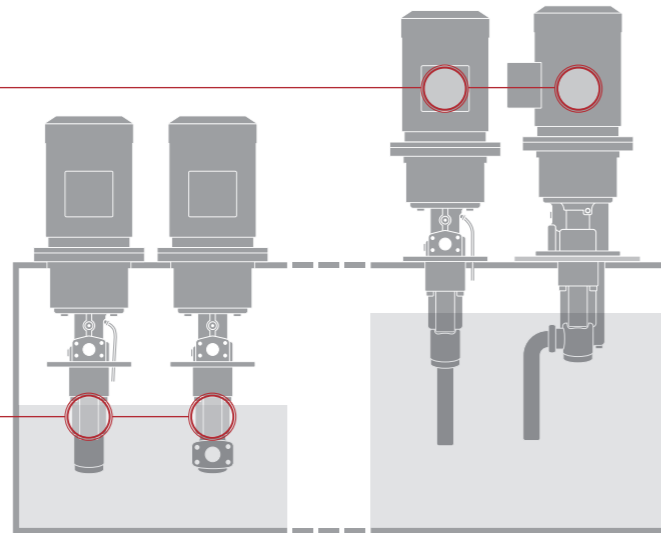

MAXIMAL ZULÄSSIGER LUFTGEHALT

10%: Emulsionen und Lösungen
7%: Schneidöl

Leitungsparameter ①	
Fördermenge (Q)	10 bis 80 l/min
Förderflüssigkeitstemperatur (t)	Bis 80 °C
Saug-/Zulaufdruck (p _s)	Bis 6 bar
Differenzdruck (Δp)	Bis zu 100 bar (Emulsion)
Pumpenenddruck (p _d)	Bis zu 100 bar
Viskositätsbereich ()	1 bis 760 mm ² /s
Verschmutzungsgrad	Bis 250 mg/l ③
Filterfeinheit	Bis 100 µm ③

① Für andere Leistungsanforderungen stehen weitere Pumpenbaureihen zur Verfügung.
② Der Eingangsdruck plus Differenzdruck plus Druckanstieg durch das Hydrauliksystem darf den Pumpenenddruck nicht überschreiten.
③ Druck, Verschmutzungsgrad und Filterfeinheit müssen aufeinander abgestimmt sein.

EMTEC-C HAUPTABMESSUNGEN

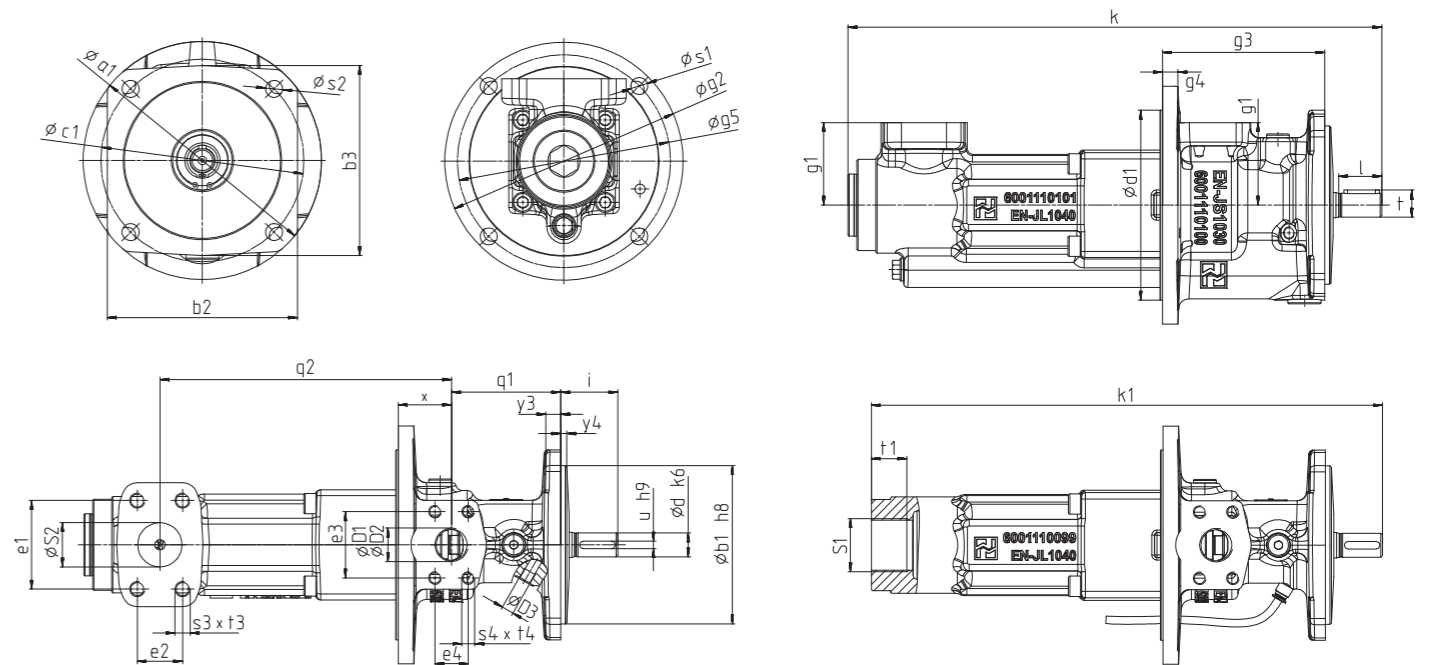

Pumpenbaugröße	Pumpenabmessungen (Metrisch – mm)												Wellenende				Flanschdeckel (DIN ISO 3019-2)									
	k	k1	i	q1	q2	x	g1	g2	g3	g4	g5	g6	d1	s1	d	l	u	t	a1	b1	b2	b3	c1	s2	y3	y4
EMT-C 20	421	403	45	86	230	42	65	188	128	12	168	-	150	13,5	19	34	6	21,5	188	125	150	150	160	13,5	12	5
EMT-C 40	464	453	45	86	273	42	65	188	128	12	168	-	150	13,5	19	34	6	21,5	188	125	150	150	160	13,5	12	5

Pumpenbaugröße	Pumpenabmessungen (US – Zoll)												Wellenende				Flanschdeckel (DIN ISO 3019-2)wv									
	k	k1	i	q1	q2	x	g1	g2	g3	g4	g5	g6	d1	s1	d	l	u	t	a1	b1	b2	b3	c1	s2	y3	y4
EMT-C 20	16.57	15.87	1.77	3.39	9.06	1.65	2.56	7.40	5.04	0.47	6.61	-	5.91	0.53	0.75	1.34	0.24	0.85	7.40	4.92	5.91	5.91	6.30	0.53	0.47	0.20
EMT-C 40	18.27	17.83	1.77	3.39	10.75	1.65	2.56	7.40	5.04	0.47	6.61	-	5.91	0.53	0.75	1.34	0.24	0.85	7.40	4.92	5.91	5.91	6.30	0.53	0.47	0.20

Pumpenbaugröße	Rohrgewinde		SAE Saugflansch (Metrisch - mm)					SAE Druckflansch					Leckageaustritt	
	Saugflansch		D1 = Rohrgewindeanschluss					D1 = Rohrgewindeanschluss						
	S1	t1	Zoll	s3xt3	e1	e2	S2	Zoll	s4xt4	e3	e4	D1		D2
EMT-C 20	G1¼	28	1½	M12x18	69,9	35,7	35	1	M10x18	52,4	26,2	G ¾	25	G 1/8
EMT-C 40	G1¼	28	1½	M12x18	69,9	35,7	35	1	M10x18	52,4	26,2	G ¾	25	G 1/8

Pumpenbaugröße	Rohrgewinde		SAE Saugflansch (US - Zoll)					SAE Druckflansch					Leckageaustritt	
	Saugflansch		D1 = Rohrgewindeanschluss					D1 = Rohrgewindeanschluss						
	S1	t1	Zoll	s3xt3	e1	e2	S2	Zoll	s4xt4	e3	e4	D1		D2
EMT-C 20	G1¼	1.10	1½	M12x18	2.75	1.41	1.38	1	M10x18	2.06	1.03	G ¾	0.98	G 1/8
EMT-C 40	G1¼	1.10	1½	M12x18	2.75	1.41	1.38	1	M10x18	2.06	1.03	G ¾	0.98	G 1/8

LEISTUNGSTABELLE

EMTEC-C

Drehzahl: 1450 1/min Kapazität: Q [l/min]
 Frequenz: 50 Hz Leistungsbedarf: P [kW]

Viskosität [mm²/s]	1.2 mm²/s = Emulsion / 20 mm²/s = Schneidöl mit EP-Additiv																												
	1.2 mm²/s	20 mm²/s	1.2 mm²/s	20 mm²/s	1.2 mm²/s	20 mm²/s	1.2 mm²/s	20 mm²/s	1.2 mm²/s	20 mm²/s	1.2 mm²/s	20 mm²/s	1.2 mm²/s	20 mm²/s	1.2 mm²/s	20 mm²/s	1.2 mm²/s	20 mm²/s	1.2 mm²/s	20 mm²/s									
Druck [bar]	0	10	20	30	40	50	60	70	80	90	100																		
20-28	Q	10.2	10.2	8.0	9.7	6.9	9.3	6.1	8.9	5.3	8.6	4.7	8.2	4.1	7.9	3.5	7.6	3.0	7.3	-	7.0	-	6.7						
	P	0.1	0.1	0.3	0.3	0.4	0.4	0.6	0.6	0.8	0.8	1.0	1.0	1.1	1.1	1.3	1.3	1.5	1.5	-	1.6	-	1.8						
20-38	Q	15.4	15.4	12.8	14.8	11.5	14.4	10.5	13.9	9.6	13.5	8.8	13.1	8.1	12.7	7.4	12.3	6.8	12.0	6.2	11.6	5.6	11.2						
	P	0.1	0.1	0.4	0.4	0.6	0.6	0.9	0.9	1.1	1.1	1.4	1.4	1.7	1.7	1.9	1.9	2.2	2.2	2.4	2.4	2.7	2.7						
20-46	Q	20.3	20.3	16.7	19.5	14.9	18.8	13.6	18.2	12.4	17.7	11.3	17.1	10.3	16.6	9.4	16.1	8.5	15.6	7.7	15.1	6.9	14.6						
	P	0.1	0.1	0.4	0.4	0.8	0.8	1.1	1.1	1.5	1.5	1.8	1.8	2.1	2.1	2.5	2.5	2.8	2.8	3.2	3.2	3.5	3.5						
20-56	Q	28.4	28.4	22.5	27.1	19.6	26.0	17.3	25.0	15.3	24.1	13.6	23.2	11.9	22.3	10.4	21.5	9.0	20.6	7.6	19.8	-	19.0						
	P	0.1	0.1	0.6	0.6	1.1	1.1	1.5	1.5	2.0	2.0	2.5	2.5	3.0	3.0	3.4	3.4	3.9	3.9	4.4	4.4	-	4.8						
40-38	Q	31.9	31.9	26.3	30.7	23.5	29.6	21.3	28.7	19.4	27.8	17.7	26.9	16.2	26.1	14.7	25.3	13.4	24.5	12.1	23.7	10.9	22.9						
	P	0.3	0.3	0.7	0.8	1.2	1.3	1.7	1.9	2.3	2.4	2.8	2.9	3.3	3.5	3.9	4.0	4.4	4.5	4.9	5.0	5.5	5.6						
40-46	Q	42.6	42.6	34.9	40.9	31.2	39.5	28.3	38.2	25.7	37.0	23.4	35.8	21.3	34.7	19.4	33.6	17.5	32.5	15.8	31.5	14.1	30.5						
	P	0.3	0.3	0.8	1.0	1.6	1.7	2.3	2.4	3.0	3.1	3.7	3.8	4.4	4.5	5.1	5.2	5.8	5.9	6.5	6.6	7.2	7.4						

EMTEC-C

Drehzahl: 1450 rpm Kapazität: Q [GPM]
 Frequenz: 50 Hz Leistungsbedarf: P [BHP]

Viskosität [cSt]	1.2 cSt = Emulsion / 20 cSt = Schneidöl mit EP-Additiv																												
	1.2 cSt	20 cSt	1.2 cSt	20 cSt	1.2 cSt	20 cSt	1.2 cSt	20 cSt	1.2 cSt	20 cSt	1.2 cSt	20 cSt	1.2 cSt	20 cSt	1.2 cSt	20 cSt	1.2 cSt	20 cSt	1.2 cSt	20 cSt									
Druck [psi]	0	145	290	435	580	725	870	1015	1160	1305	1450																		
20-28	Q	2.7	2.7	2.1	2.6	1.8	2.4	1.6	2.4	1.4	2.3	1.2	2.2	1.1	2.1	0.9	2.0	0.8	1.9	-	1.8	-	1.8						
	P	0.1	0.1	0.4	0.4	0.6	0.6	0.8	0.8	1.1	1.1	1.3	1.3	1.5	1.5	1.7	1.7	2.0	2.0	-	2.2	-	2.4						
20-38	Q	4.1	4.1	3.4	3.9	3.0	3.8	2.8	3.7	2.5	3.6	2.3	3.5	2.1	3.4	2.0	3.3	1.8	3.2	1.6	3.1	1.5	3.0						
	P	0.1	0.1	0.5	0.5	0.8	0.8	1.2	1.2	1.5	1.5	1.9	1.9	2.2	2.2	2.6	2.6	2.9	2.9	3.3	3.3	3.6	3.6						
20-46	Q	5.4	5.4	4.4	5.1	3.9	5.0	3.6	4.8	3.3	4.7	3.0	4.5	2.7	4.4	2.5	4.2	2.2	4.1	2.0	4.0	1.8	3.9						
	P	0.1	0.1	0.6	0.6	1.1	1.1	1.5	1.5	2.0	2.0	2.4	2.4	2.9	2.9	3.3	3.3	3.8	3.8	4.2	4.2	4.7	4.7						
20-56	Q	7.5	7.5	5.9	7.2	5.2	6.9	4.6	6.6	4.0	6.4	3.6	6.1	3.2	5.9	2.8	5.7	2.4	5.5	2.0	5.2	-	5.0						
	P	0.1	0.1	0.8	0.8	1.4	1.4	2.1	2.1	2.7	2.7	3.3	3.3	4.0	4.0	4.6	4.6	5.2	5.2	5.9	5.9	-	6.5						
40-38	Q	8.4	8.4	6.9	8.1	6.2	7.8	5.6	7.6	5.1	7.3	4.7	7.1	4.3	6.9	3.9	6.7	3.5	6.5	3.2	6.3	2.9	6.1						
	P	0.2	0.3	0.9	1.1	1.6	1.8	2.3	2.5	3.0	3.2	3.8	3.9	4.5	4.6	5.2	5.3	5.9	6.1	6.6	6.8	7.3	7.5						
40-46	Q	11.2	11.2	9.2	10.8	8.2	10.4	7.5	10.1	6.8	9.8	6.2	9.5	5.6	9.2	5.1	8.9	4.6	8.6	4.2	8.3	3.7	8.0						
	P	0.2	0.3	1.1	1.3	2.1	2.3	3.0	3.2	4.0	4.2	4.9	5.1	5.9	6.1	6.8	7.0	7.8	8.0	8.8	8.9	9.7	9.9						

LEISTUNGSTABELLE

EMTEC-C

Drehzahl: 1750 1/min Kapazität: Q [l/min]
 Frequenz: 60 Hz Leistungsbedarf: P [kW]

Viskosität [mm²/s]	1.2.2 mm²/s = Emulsion / 20 mm²/s = Schneidöl mit EP-Additiv																												
	1.2 mm²/s	20 mm²/s	1.2 mm²/s	20 mm²/s	1.2 mm²/s	20 mm²/s	1.2 mm²/s	20 mm²/s	1.2 mm²/s	20 mm²/s	1.2 mm²/s	20 mm²/s	1.2 mm²/s	20 mm²/s	1.2 mm²/s	20 mm²/s	1.2 mm²/s	20 mm²/s	1.2 mm²/s	20 mm²/s									
Druck [bar]	0	10	20	30	40	50	60	70	80	90	100																		
20-28	Q	12.3	12.3	10.1	11.8	9.0	11.4	8.2	11.0	7.4	10.7	6.8	10.3	6.2	10.0	5.6	9.7	5.1	9.4	4.6	9.1	4.1	8.8						
	P	0.1	0.1	0.4	0.4	0.6	0.6	0.8	0.8	1.0	1.0	1.2	1.2	1.4	1.4	1.6	1.6	1.8	1.8	2.0	2.0	2.2	2.2						
20-38	Q	18.6	18.6	16.0	18.0	14.7	17.6	13.7	17.1	12.8	16.7	12.0	16.3	11.3	15.9	10.6	15.5	10.0	15.2	9.4	14.8	8.8	14.4						
	P	0.1	0.1	0.5	0.5	0.8	0.8	1.1	1.1	1.4	1.4	1.7	1.7	2.0	2.0	2.3	2.3	2.6	2.6	2.9	2.9	3.2	3.2						
20-46	Q	24.5	24.5	20.9	23.7	19.1	23.0	17.8	22.4	16.6	21.9	15.5	21.3	14.5	20.8	13.6	20.3	12.7	19.8	11.9	19.3	11.1	18.8						
	P	0.1	0.1	0.6	0.6	1.0	1.0	1.4	1.4	1.8	1.8	2.2	2.2	2.6	2.6	3.0	3.0	3.4	3.4	3.8	3.8	4.2	4.2						
20-56	Q	34.3	34.3	28.4	33.0	25.5	31.9	23.2	30.9	21.2	30.0	19.4	29.1	17.8	28.2	16.3	27.4	14.9	26.5	13.5	25.7	12.2	24.9						
	P	0.1	0.1	0.7	0.7	1.3	1.3	1.9	1.9	2.4	2.4	3.0	3.0	3.6	3.6	4.1	4.1	4.7	4.7	5.3	5.3	5.9	5.9						
40-38	Q	38.5	38.5	32.9	37.3	30.1	36.2	27.9	35.3	26.0	34.4	24.3	33.6	22.8	32.7	21.3	31.9	20.0	31.1	18.7	30.3	17.5	29.6						
	P	0.2	0.3	0.8	1.0	1.5	1.6	2.1	2.3	2.8	2.9	3.4	3.6	4.0	4.2	4.7	4.8	5.3	5.5	6.0	6.1	6.6	6.8						
40-46	Q	51.4	51.4	43.7	49.7	40.0	48.3	37.1	47.0	34.5	45.8	32.2	44.7	30.1	43.5	28.2	42.4	26.3	41.4	24.6	40.3	22.9	39.3						
	P	0.2	0.3	1.0	1.2	1.9	2.1	2.8	2.9	3.6	3.8	4.5	4.6	5.3	5.5	6.2	6.3	7.0	7.2	7.9	8.1	8.7	8.9						

EMTEC-C

Drehzahl: 1750 rpm Kapazität: Q [GPM]
 Frequenz: 60 Hz Leistungsbedarf: P [BHP]

Viskosität [cSt]	1.2 cSt = Emulsion / 20 cSt = Schneidöl mit EP-Additiv																												
	1.2 cSt	20 cSt	1.2 cSt	20 cSt	1.2 cSt	20 cSt	1.2 cSt	20 cSt	1.2 cSt	20 cSt	1.2 cSt	20 cSt	1.2 cSt	20 cSt	1.2 cSt	20 cSt	1.2 cSt	20 cSt	1.2 cSt	20 cSt									
Druck [psi]	0	145	290	435	580	725	870	1015	1160	1305	1450																		
20-28	Q	3.2	3.2	2.7	3.1	2.4	3.0	2.2	2.9	2.0	2.8	1.8	2.7	1.6	2.6	1.5	2.6	1.3	2.5	1.2	2.4	1.1	2.3						
	P	0.2	0.2	0.5	0.5	0.7	0.7	1.0	1.0	1.3	1.3	1.6	1.6	1.8	1.8	2.1	2.1	2.4	2.4	2.7	2.7	2.9	2.9						
20-38	Q	4.9	4.9	4.2	4.8	3.9	4.6	3.6	4.5	3.4	4.4	3.2	4.3	3.0	4.2	2.8	4.1	2.6	4.0	2.5	3.9	2.3	3.8						
	P	0.2	0.2	0.6	0.6	1.0	1.0	1.4	1.4	1.9	1.9	2.3	2.3	2.7	2.7	3.1	3.1	3.5	3.5	3.9	3.9	4.4	4.4						
20-46	Q	6.5	6.5	5.5	6.3	5.1	6.1	4.7	5.9	4.4	5.8	4.1	5.6	3.8	5.5	3.6	5.4	3.4	5.2	3.1	5.1	2.9	5.0						
	P	0.2	0.2	0.7	0.7	1.3	1.3	1.8	1.8	2.4	2.4	2.9	2.9	3.5	3.5	4.0	4.0	4.6	4.6	5.1	5.1	5.7	5.7						
20-56	Q	9.1	9.1	7.5	8.7	6.7	8.4	6.1	8.2	5.6	7.9	5.1	7.7	4.7	7.5	4.3	7.2	3.9	7.0	3.6	6.8	3.2	6.6						
	P	0.2	0.2	1.0	1.0	1.7	1.7	2.5	2.5	3.3	3.3	4.0	4.0	4.8	4.8	5.6	5.6	6.3	6.3	7.1	7.1	7.9	7.9						
40-38	Q	10.2	10.2	8.7	9.8	8.0	9.6	7.4	9.3	6.9	9.1	6.4	8.9	6.0	8.6	5.6	8.4	5.3	8.2	4.9	8.0	4.6	7.8						
	P	0.2	0.5	1.1	1.3	2.0	2.2	2.8	3.0	3.7	3.9	4.6	4.8	5.4	5.6	6.3	6.5	7.1	7.4	8.0	8.2	8.9	9.1						
40-46	Q	13.6	13.6	11.6	13.1	10.6	12.8	9.8	12.4	9.1	12.1	8.5	11.8	8.0	11.5	7.4	11.2	7.0	10.9	6.5	10.6	6.1	10.4						
	P	0.2	0.5	1.4	1.6	2.5	2.8	3.7	3.9	4.8	5.1	6.0	6.2	7.1	7.4	8.3	8.5	9.4	9.6	10.6	10.8	11.7	11.9						

LEISTUNGSTABELLE

EMTEC-C

Drehzahl: 2950 1/min Kapazität : Q [l/min]
 Frequenz: 50 Hz Leistungsbedarf: P [kW]

Viskosität [mm²/s]	1.2 mm²/s = Emulsion / 20 mm²/s = Schneidöl mit EP-Additiv																							
	1.2 mm²/s	20 mm²/s	1.2 mm²/s	20 mm²/s	1.2 mm²/s	20 mm²/s	1.2 mm²/s	20 mm²/s	1.2 mm²/s	20 mm²/s	1.2 mm²/s	20 mm²/s	1.2 mm²/s	20 mm²/s	1.2 mm²/s	20 mm²/s	1.2 mm²/s	20 mm²/s	1.2 mm²/s	20 mm²/s				
Druck [bar]	0	10	20	30	40	50	60	70	80	90	100													
20-28	Q	20.7	20.7	18.5	20.2	17.4	19.8	16.6	19.4	15.9	19.1	15.2	18.8	14.6	18.4	14.0	18.1	13.5	17.8	13.0	17.5	12.5	17.2	
	P	0.3	0.3	0.7	0.7	1.0	1.0	1.4	1.4	1.7	1.7	2.0	2.0	2.4	2.4	2.7	2.7	3.1	3.1	3.4	3.4	3.8	3.8	
20-38	Q	31.4	31.4	28.7	30.8	27.4	30.3	26.4	29.9	25.5	29.5	24.7	29.1	23.9	28.7	23.3	28.3	22.6	27.9	22.0	27.6	21.4	27.2	
	P	0.3	0.3	0.8	0.8	1.4	1.4	1.9	1.9	2.4	2.4	2.9	2.9	3.5	3.5	4.0	4.0	4.5	4.5	5.0	5.0	5.6	5.6	
20-46	Q	41.3	41.3	37.8	40.5	36.0	39.9	34.7	39.3	33.5	38.7	32.4	38.2	31.4	37.7	30.5	37.2	29.6	36.7	28.8	36.2	28.0	35.7	
	P	0.3	0.3	1.0	1.0	1.7	1.7	2.4	2.4	3.1	3.1	3.8	3.8	4.4	4.4	5.1	5.1	5.8	5.8	6.5	6.5	7.2	7.2	
20-56	Q	57.8	57.8	52.0	56.5	49.1	55.5	46.8	54.5	44.8	53.6	43.0	52.7	41.4	51.8	39.8	51.0	38.4	50.2	37.0	49.4	35.7	48.6	
	P	0.3	0.3	1.3	1.3	2.2	2.2	3.2	3.2	4.2	4.2	5.1	5.1	6.1	6.1	7.1	7.1	8.0	8.0	9.0	9.0	10.0	10.0	
40-38	Q	65.0	65.0	59.4	63.7	56.6	62.7	54.4	61.8	52.5	60.9	50.8	60.1	49.2	59.2	47.8	58.4	46.4	57.6	45.1	56.9	43.8	56.1	
	P	0.4	0.8	1.5	1.8	2.6	2.9	3.7	4.0	4.7	5.1	5.8	6.2	6.9	7.3	8.0	8.3	9.1	9.4	10.2	10.5	11.2	11.6	
40-46	Q	86.6	86.6	79.1	84.9	75.4	83.6	72.4	82.3	69.8	81.1	67.5	80.0	65.4	78.9	63.5	77.8	61.6	76.7	59.8	75.7	58.2	74.7	
	P	0.4	0.8	1.8	2.2	3.3	3.6	4.7	5.1	6.2	6.5	7.6	8.0	9.1	9.4	10.5	10.9	12.0	12.3	13.4	13.7	14.8	15.2	

EMTEC-C

Drehzahl: 2950 rpm Kapazität: Q [GPM]
 Frequenz: 50 Hz Leistungsbedarf: P [BHP]

Viskosität [cSt]	1.2 cSt = Emulsion / 20 cSt = Schneidöl mit EP-Additiv																							
	1.2 cSt	20 cSt	1.2 cSt	20 cSt	1.2 cSt	20 cSt	1.2 cSt	20 cSt	1.2 cSt	20 cSt	1.2 cSt	20 cSt	1.2 cSt	20 cSt	1.2 cSt	20 cSt	1.2 cSt	20 cSt	1.2 cSt	20 cSt				
Druck [psi]	0	145	290	435	580	725	870	1015	1160	1305	1450													
20-28	Q	5.5	5.5	4.9	5.3	4.6	5.2	4.4	5.1	4.2	5.0	4.0	4.9	3.9	4.9	3.7	4.8	3.6	4.7	3.4	4.6	3.3	4.5	
	P	0.4	0.4	0.9	0.9	1.4	1.4	1.8	1.8	2.3	2.3	2.7	2.7	3.2	3.2	3.7	3.7	4.1	4.1	4.6	4.6	5.0	5.0	
20-38	Q	8.3	8.3	7.6	8.1	7.3	8.0	7.0	7.9	6.8	7.8	6.5	7.7	6.4	7.6	6.2	7.5	6.0	7.4	5.8	7.3	5.7	7.2	
	P	0.4	0.4	1.1	1.1	1.8	1.8	2.5	2.5	3.2	3.2	3.9	3.9	4.6	4.6	5.3	5.3	6.0	6.0	6.7	6.7	7.4	7.4	
20-46	Q	10.9	10.9	10.0	10.7	9.5	10.5	9.1	10.4	8.8	10.2	8.5	10.1	8.3	9.9	8.0	9.8	7.8	9.7	7.6	9.5	7.4	9.4	
	P	0.4	0.4	1.4	1.4	2.3	2.3	3.2	3.2	4.1	4.1	5.0	5.0	6.0	6.0	6.9	6.9	7.8	7.8	8.7	8.7	9.7	9.7	
20-56	Q	15.3	15.3	13.7	14.9	12.9	14.6	12.3	14.4	11.8	14.1	11.3	13.9	10.9	13.7	10.5	13.4	10.1	13.2	9.8	13.0	9.4	12.8	
	P	0.4	0.4	1.7	1.7	3.0	3.0	4.3	4.3	5.6	5.6	6.9	6.9	8.2	8.2	9.5	9.5	10.8	10.8	12.1	12.1	13.4	13.4	
40-38	Q	17.2	17.2	15.7	16.8	14.9	16.6	14.4	16.3	13.9	16.1	13.4	15.8	13.0	15.6	12.6	15.4	12.3	15.2	11.9	15.0	11.6	14.8	
	P	0.5	1.0	2.0	2.5	3.4	3.9	4.9	5.4	6.4	6.8	7.8	8.3	9.3	9.7	10.7	11.2	12.2	12.6	13.6	14.1	15.1	15.5	
40-46	Q	22.9	22.9	20.9	22.4	19.9	22.1	19.1	21.7	18.4	21.4	17.8	21.1	17.3	20.8	16.7	20.5	16.3	20.2	15.8	20.0	15.4	19.7	
	P	0.5	1.0	2.5	2.9	4.4	4.9	6.4	6.8	8.3	8.8	10.2	10.7	12.2	12.6	14.1	14.6	16.0	16.5	18.0	18.4	19.9	20.4	

LEISTUNGSTABELLE

EMTEC-C

Drehzahl: 3550 1/min Kapazität: Q [l/min]
 Frequenz: 60 Hz Leistungsbedarf: P [kW]

Viskosität [mm²/s]	1.2 mm²/s = Emulsion / 20 mm²/s = Schneidöl mit EP-Additiv																							
	1.2 mm²/s	20 mm²/s	1.2 mm²/s	20 mm²/s	1.2 mm²/s	20 mm²/s	1.2 mm²/s	20 mm²/s	1.2 mm²/s	20 mm²/s	1.2 mm²/s	20 mm²/s	1.2 mm²/s	20 mm²/s	1.2 mm²/s	20 mm²/s	1.2 mm²/s	20 mm²/s	1.2 mm²/s	20 mm²/s				
Druck [bar]	0	10	20	30	40	50	60	70	80	90	100													
20-28	Q	24.9	24.9	22.7	24.4	21.6	24.0	20.8	23.6	20.0	23.3	19.4	22.9	18.8	22.6	18.2	22.3	17.7	22.0	17.2	21.7	16.7	21.4	
	P	0.4	0.4	0.8	0.8	1.2	1.2	1.7	1.7	2.1	2.1	2.5	2.5	2.9	2.9	3.3	3.3	3.7	3.7	4.1	4.1	4.6	4.6	
20-38	Q	37.8	37.8	35.1	37.2	33.8	36.7	32.8	36.3	31.9	35.9	31.1	35.5	30.4	35.1	29.7	34.7	29.1	34.3	28.5	33.9	27.9	33.6	
	P	0.4	0.4	1.1	1.1	1.7	1.7	2.3	2.3	2.9	2.9	3.6	3.6	4.2	4.2	4.8	4.8	5.5	5.5	6.1	6.1	6.7	6.7	
20-46	Q	49.7	49.7	46.1	48.9	44.3	48.2	43.0	47.6	41.8	47.1	40.7	46.5	39.7	46.0	38.8	45.5	37.9	45.0	37.1	44.5	36.3	44.0	
	P	0.4	0.4	1.2	1.2	2.1	2.1	2.9	2.9	3.7	3.7	4.6	4.6	5.4	5.4	6.2	6.2	7.0	7.0	7.9	7.9	8.7	8.7	
20-56	Q	69.6	69.6	63.6	68.3	60.8	67.2	58.5	66.2	56.5	65.3	54.7	64.4	53.1	63.5	51.6	62.6	50.1	61.8	48.8	61.0	47.5	60.2	
	P	0.4	0.4	1.6	1.6	2.7	2.7	3.9	3.9	5.1	5.1	6.2	6.2	7.4	7.4	8.5	8.5	9.7	9.7	10.9	10.9	12.0	12.0	
40-38	Q	78.2	78.2	72.5	76.9	69.8	75.9	67.6	74.9	65.7	74.1	64.0	73.2	62.4	72.4	61.0	71.5	59.6	70.7	58.3	70.0	57.1	69.2	
	P	0.5	1.0	1.8	2.3	3.1	3.6	4.4	4.9	5.7	6.2	7.1	7.5	8.4	8.8	9.7	10.1	11.0	11.4	12.3	12.7	13.6	14.0	
40-46	Q	104.2	104.2	96.6	102.5	92.9	101.1	89.9	99.9	87.4	98.7	85.1	97.5	83.0	96.4	81.0	95.3	79.2	94.2	77.4	93.1	75.8	92.1	
	P	0.5	1.0	2.3	2.7	4.0	4.5	5.7	6.2	7.5	7.9	9.2	9.7	11.0	11.4	12.7	13.2	14.4	14.9	16.2	16.6	17.9	18.4	

EMTEC-C

Drehzahl: 3550 rpm Kapazität: Q [GPM]
 Frequenz: 60 Hz Leistungsbedarf: P [BHP]

Viskosität [cSt]	1.2 cSt = Emulsion / 20 cSt = Schneidöl mit EP-Additiv																							
	1.2 cSt	20 cSt	1.2 cSt	20 cSt	1.2 cSt	20 cSt	1.2 cSt	20 cSt	1.2 cSt	20 cSt	1.2 cSt	20 cSt	1.2 cSt	20 cSt	1.2 cSt	20 cSt	1.2 cSt	20 cSt	1.2 cSt	20 cSt				
Druck [psi]	0	145	290	435	580	725	870	1015	1160	1305	1450													
20-28	Q	6.6	6.6	6.0	6.4	5.7	6.4	5.5	6.3	5.3	6.3	5.1	6.2	5.0	6.2	4.8	6.2	4.7	6.1	4.5	6.1	4.4	6.1	
	P	0.6	0.4	1.1	1.1	1.7	1.7	2.2	2.2	2.8	2.8	3.3	3.3	3.9	3.9	4.5	4.5	5.0	5.0	5.6	5.6	6.1	6.1	
20-38	Q	10.0	10.0	9.3	9.8	8.9	9.7	8.7	9.7	8.4	9.6	8.2	9.6	8.0	9.5	7.9	9.5	7.7	9.5	7.5	9.4	7.4	9.4	
	P	0.6	0.4	1.4	1.4	2.3	2.3	3.1	3.1	3.9	3.9	4.8	4.8	5.6	5.6	6.5	6.5	7.3	7.3	8.2	8.2	9.0	9.0	
20-46	Q	13.1	13.1	12.2	12.9	11.7	12.8	11.3	12.7	11.0	12.7	10.7	12.6	10.5	12.5	10.2	12.5	10.0	12.4	9.8	12.4	9.6	12.3	
	P	0.6	0.4	1.7	1.7	2.8	2.8	3.9	3.9	5.0	5.0	6.1	6.1	7.2	7.2	8.3	8.3	9.5	9.5	10.6	10.6	11.7	11.7	
20-56	Q	18.4	18.4	16.8	18.0	16.1	17.9	15.4	17.7	14.9	17.6	14.5	17.5	14.0	17.4	13.6	17.3	13.2	17.2	12.9	17.2	12.6	17.1	
	P	0.6	0.4	2.1	2.1	3.7	3.7	5.2	5.2	6.8	6.8	8.3	8.3	9.9	9.9	11.5	11.5	13.0	13.0	14.6	14.6	16.1	16.1	
40-38	Q	20.7	20.7	19.2	20.3	18.4	20.2	17.8	20.0	17.3	19.9	16.9	19.8	16.5	19.7	16.1	19.6	15.7	19.6	15.4	19.5	15.1	19.4	
	P	0.7	1.0	2.5	3.1	4.2	4.8	6.0	6.6	7.7	8.3	9.5	10.1	11.2	11.8	12.9	13.6	14.7	15.3	16.4	17.1	18.2	18.8	
40-46	Q	27.5	27.5	25.5	27.1	24.5	26.9	23.8	26.7	23.1	26.5	22.5	26.4	21.9	26.3	21.4	26.2	20.9	26.1	20.5	26.0	20.0	25.9	
	P	0.7	1.0	3.0	3.7	5.4	6.0	7.7	8.3	10.0	10.7	12.4	13.0	14.7	15.3	17.0	17.6	19.4	20.0	21.7	22.3	24.0	24.6	



CIRCOR ist ein marktführender, weltweit tätiger Anbieter integrierter Durchflussregelungslösungen, der sich auf die Herstellung hochtechnischer Ventile, Instrumente, Pumpen, Rohrleitungsprodukte und -dienstleistungen sowie Zubehör für kritische und schwere Anwendungen in der Öl- und Gas-, Stromerzeugungs-, Anlagen-, Prozess-, See-, Luft- und Raumfahrt- sowie Rüstungsindustrie spezialisiert hat.

Excellence in Flow Control

Asien | Europa | Naher Osten | Nordamerika | Südamerika

ALLWEILER GmbH
Allweilerstr. 1 78315 Radolfzell
Deutschland
+49 7732 86 0

CIRCOR
1710 Airport Rd
Monroe, NC 28110
USA

Unit 804, Venture International Park
Building B No. 2679
Hechuan Road
Shanghai 201103 China
+86 21 6248 1395



DE-IND025-20187, Ident-No. 488212 - D/03-2019

circorpt.com/emtec-de

CIRCOR and ALLWEILER are registered trademarks of CIRCOR International or its subsidiaries in the U.S. and/or other countries.
©2019, CIRCOR International. All rights reserved. DE-IND025-20187, 488212 - D/03.2019