



# ALLHEAT®: Some Like it Hot

Pumps that are designed specifically for heat transfer.



© NESS Wärmetechnik GmbH

## REDEFINING HANDLING OF HEAT TRANSFER FLUIDS

CIRCOR is redefining what's possible in Heat Transfer applications, collaborating with engineers and operators like you to develop the best fluid-handling solutions for your application. With its ALLHEAT® series, CIRCOR is defining a new generation of handling heat transfer fluids. The ALLHEAT® series is one of the few pump designs on the market that (with absolutely no changes!) can pump thermal oil up to 400 °C/752 °F, or hot water up to about 207 °C/405 °F. In addition, ALLHEAT® can also be used with modern very-low-viscosity synthetic thermal oils with virtually no limitations. You'll never find a more universal pump!

More than 100,000 thermal oil pumps have been built and commissioned during the last fifteen years. Today, the Allweiler brand of CIRCOR commands 25 % of the global market, making it one of the major players in the industry. Allweiler® thermal oil pumps are in operation in virtually every industrialized country of the world.

Your toughest challenges are addressed with more than just an off-the-shelf product when you partner with CIRCOR. You get 150 years of application experience, technology that's relied on to support numerous plants every day worldwide, and a team of product and service specialists tasked with maximizing the efficiency of your operation – from the very start to the finish of your project. All of this is enabled by a broad portfolio of pumps and engineered systems from brands you and your clients know and trust — Allweiler®, Houttuin™, lmo® and Warren® — ensuring that you get the reliability your operations demand and the expert levels of service that you require during design, commissioning and throughout operations.

As your single-source global supplier, we call this "Total Savings of Ownership" reducing the overall costs of your operations and increasing your profitability.

## ALLHEAT®: PUMPS FOR THERMAL OILS AND HOT WATER

FOR MORE THAN 40 YEARS DEVELOPING AND MANUFACTURING PUMPS FOR HEAT-CARRIER FLUIDS.

If you need reliable pumps with considerably lower lifecycle costs for moving oils at temperatures as high as 400 °C/752 °F or hot water up to 207 °C/405 °F, at Allweiler® you will find just what you are looking for. CIRCOR's Allweiler® brand began developing thermal oil pumps back in 1960. Since that time, Allweiler® GmbH has produced and delivered several hundred thousand pumps for heat-carrier applications. Today, with a global market share of approximately 25 percent, Allweiler® is one of the industry's major players. In fact, Allweiler® brand heat-carrier pumps are used successfully in every industrialized country of the world. When you choose a heat-carrier pump from CIRCOR's Allweiler® brand, you are choosing a supplier with more than 40 years' experience and designs that are optimized for real-world conditions.

### For every heat carrier and every pumping task

Allweiler® produces its own pump units and complete pump packages for virtually every requirement related to heat transfer. This includes both mineral-based as well as synthetic heat-carrier oils and hot water. Depending on your exact requirements, you will choose either pumps with a shaft seal or magnetically-coupled pumps without a shaft seal.

ALLHEAT® heat-carrier pumps are universally useful for all heat-carrier liquids. ALLMAG® pumps with magnetic drive are 100-percent hermetically sealed, so they meet the most stringent environmental requirements. With process, block, and inline versions, it is easy to adapt the pumps to the installation conditions at your plant.

### Service and support guaranteed

If you decide to use an ALLHEAT® pump, you can count on rapid service at your location no matter where you are in the world. Global service and support centers ensure that customers have access to qualified maintenance for any pump unit whenever necessary.

The Allweiler® brand QuickServe® program guarantees that common wearing parts will be shipped anywhere in the world within certain response times. Depending on the pump, Allweiler® will deliver either complete repair kits or individual parts, anywhere and anytime. Repair kits contain all necessary gaskets and other wearing parts. They are delivered with an open invoice and with all necessary paperwork, so you get your parts without jumping over bureaucratic hurdles.

### WITH THE ALLHEAT® SERIES, ALLWEILER® FULLY IMPLEMENTS THE REQUIREMENTS FOR MODERN HEAT-CARRIER PUMPS:

- For all heat-transfer oils, even low-viscosity oils
- Strong seals, even for hot water above 140 °C/284 °F
- Seals are stable without external cooling
- Replace traditional water pumps with special seals
- Very mechanically durable
- Unrivalled price/performance ratio



All ALLHEAT® pumps are ATEX certified

### Maximum performance data of Allweiler brand Heat-Carrier Centrifugal Pumps\*

	Water up to 100 °C up to 212 °F	Hot water up to 207 °C up to 405 °F	Thermal oil mineral based	synthetic	with magnetic coupling	
<b>Q</b>	2,300 / 10,128	1,450 / 6,385	1,450 / 5,504	1,450 / 6,385	300 / 1,321	m³/h / gpm
<b>H</b>	145 / 476	100 / 328	145 / 476	100 / 328	145 / 476	m / ft
<b>P<sub>d</sub></b>	16 / 232	25 / 363	16 / 232	25 / 363	25 / 363	bar / psi

\* All performance data listed here and in the following tables apply to 50-Hz operation.

# THE NTT SERIES: DESIGNED TO BE ROBUST, ECONOMICAL, AND RAPIDLY AVAILABLE

A SPECIAL DESIGN ENSURES A LONG SERVICE LIFE COUPLED WITH LOW COSTS FOR MAINTENANCE AND OPERATION

## THE BENEFITS:

### Reliability

Pressure-safe, torsion-proof housing parts; designed for high operational safety.

### Maintenance-free

Uncooled, unrelieved mechanical seal.

### Energy efficiency

Air flow cools the bearing housing/throttle section and thereby also the shaft seal and groove ball bearing.

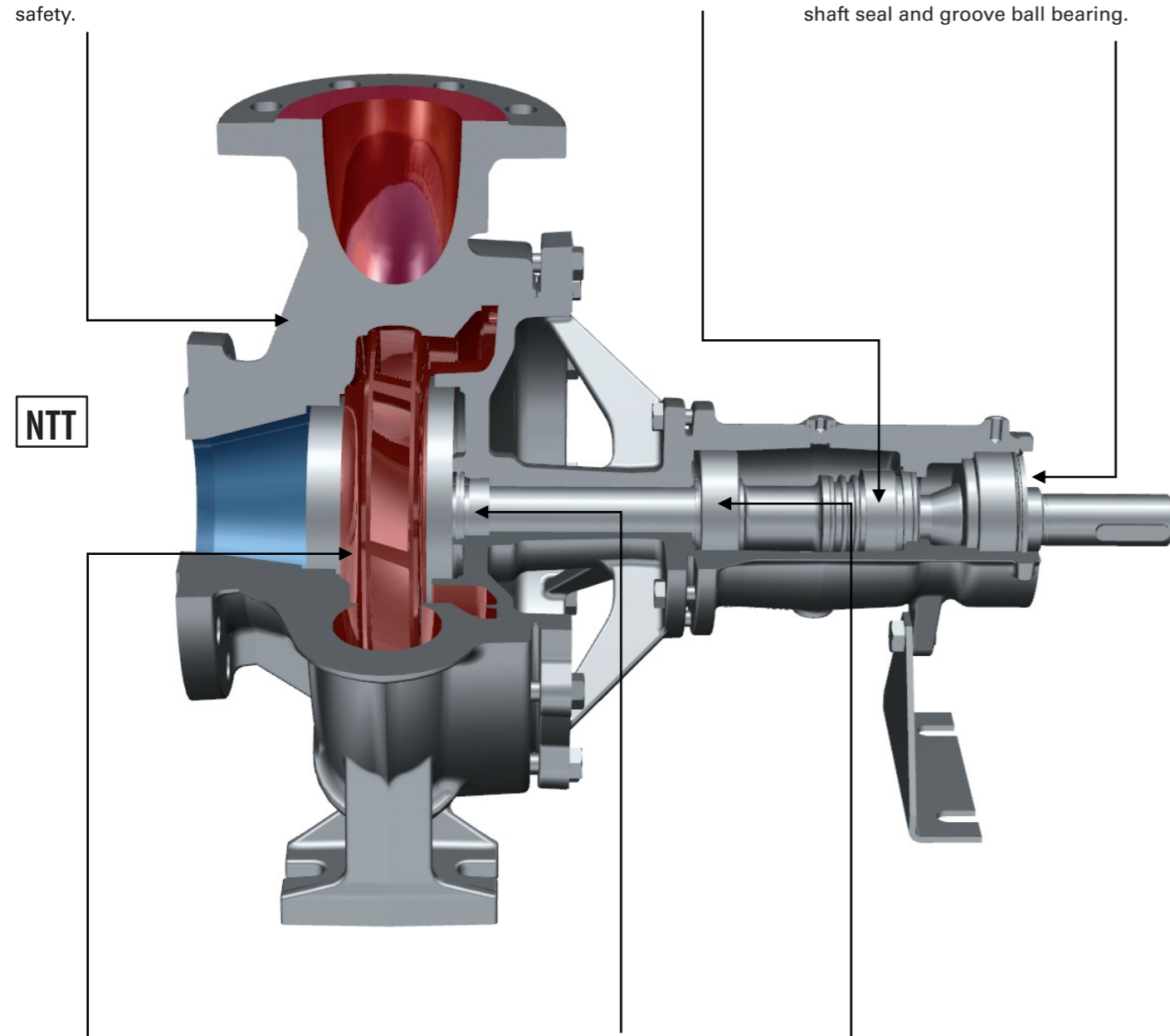

### Individually adapted for high delivery heads

One- or two-stage design depending on required delivery head. Connection dimensions are the same. High delivery heads with relatively small flow rates in the two-stage version.

### Safety

Safety stuffing box with downstream throttle/cooling section.

### Long service life

The heat barrier (cooling section) and air-flow cooling keep temperature at the liquid-side of the bearing and at the seal below 100°C/212 °F when the pumped liquid is at maximum temperature.

The NTT, NBT and NIT product series are ideal for moving mineral-based thermal oils. Their mechanical seals are located behind a heat barrier, where they are protected from high temperatures. The result is that simple standard gaskets (antimony-carbon/SiC) have a very long service life when used in the pumps. All three types are also available as two-stage versions with the same external dimensions, making them ideal for small flow rates with high delivery head.

Each version is available in several variations, so you will always get a pump that fits perfectly into your installation. Depending on how your pipes are laid out and how much space is available, one of the following will be ideal:

- NTT series with a separately-coupled motor and volute casing with foot attachment on a base plate
- NBT series in a directly-coupled block version, set up vertically or horizontally
- NIT series in a directly-coupled inline version, set up vertically or horizontally

All pumps are intended to be driven by a standard motor. The antifriction bearing on the pump side is always lubricated by the pumped liquid; on the NTT, the drive-side antifriction bearing is grease-lubricated.

### Highest safety

If the mechanical seal is compromised, additional safety elements ensure that only a small amount of liquid will leak out. Thanks to these design measures, the pumps exceed the requirements of DIN 4754. Any pumped liquid that does leak out can be completely captured and safely diverted.

The special design of the insert unit reduces temperature so effectively that the bearing and shaft seal always work flawlessly.

A quench for the mechanical seal is available as an option. This further reduces temperature at the mechanical seal and eliminates the possibility that fluid leaking out of the seal will oxidize and cause damage to the seal.



### Maximum performance data

	NTT	NBT	NIT	
Q	1,250 / 5,504	270 / 1,189	220 / 969	m <sup>3</sup> /h / gpm
H	145 / 476	145 / 476	145 / 476	m / ft
p <sub>d</sub>	16 / 232	16 / 232	16 / 232	bar / psi
t	350 / 662	350 / 662	350 / 662	°C / °F

# ALLHEAT®: INNOVATIVE DESIGN MAKES IT AN ALL-ROUND SOLUTION

SAFE IN OPERATION AND WITH A LONG SERVICE LIFE THANKS TO A SPECIAL BEARING AND SEAL DESIGNED ESPECIALLY FOR LOW-VISCOSITY LIQUIDS

## THE BENEFITS:

### Pressure safety

Housing parts constructed of ductile iron for high operational safety.

### Stability and durability

Unrivalled mechanical strength and stiffness resulting from optimally arranged stiffening ribs, a large centering diameter, and an optimized angle.

### Low maintenance

Patented large-dimension seal space to avoid gas-bubble rotation and partial dry running of the mechanical seal.

### Long service life

Optimized antifriction bearing with guard disc and special grease.

### Efficiency

Hydraulically relieved impellers are optimized for high efficiency and minimal axial thrust on the shaft bearing.

### Flexibility

Bearing-seal combination can be easily upgraded from "All-round" to Heavy-duty.

### Operational safety

A very strong plain bearing lubricated by the pumped liquid; protected against dry running and tilting, can be disassembled separately.

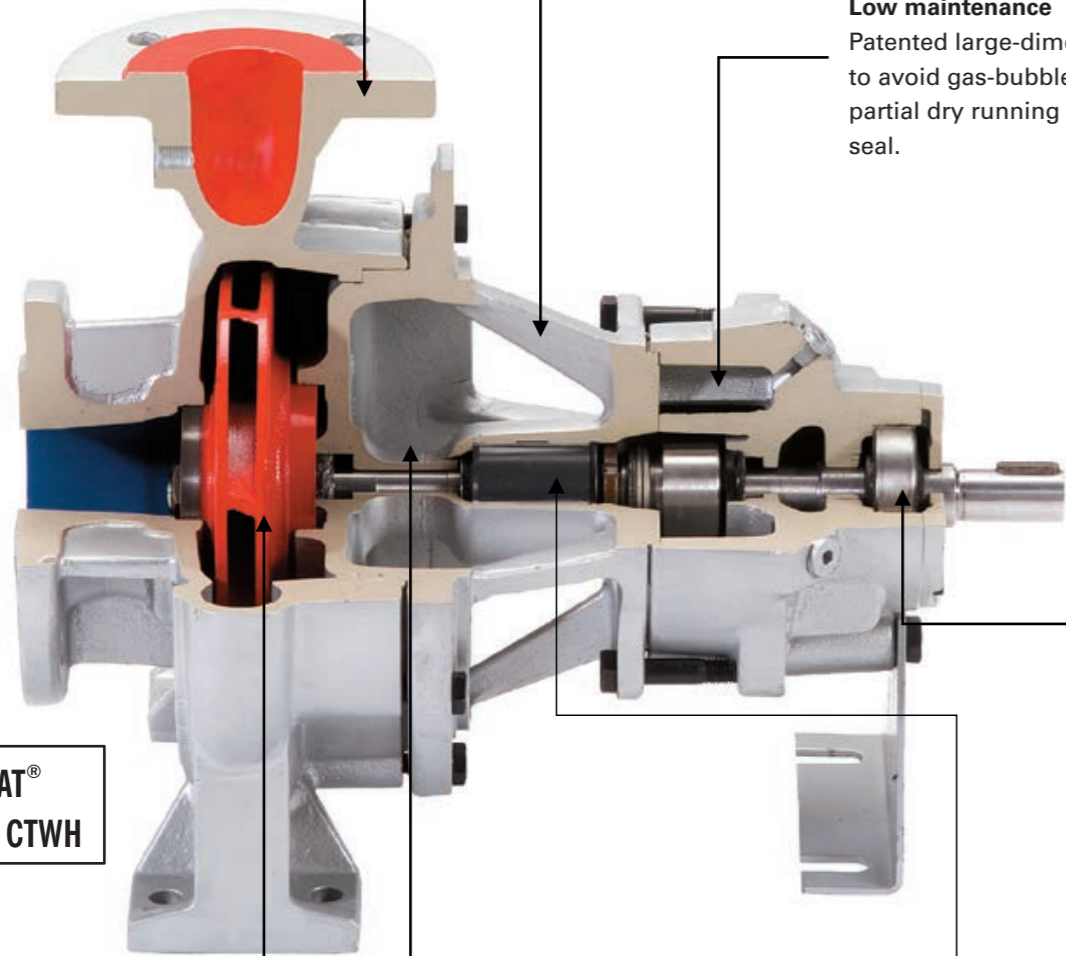

ALLHEAT®  
NTWH, CTWH

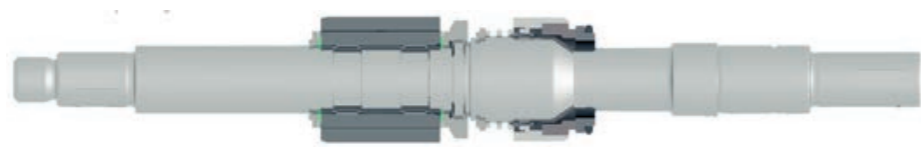

The ALLHEAT® series gives plant operators centrifugal pumps that were designed specifically for high-temperature applications employing low-viscosity heat carriers like synthetic thermal oils and hot water. These pumps have unrivalled versatility; they forgo external cooling and are extraordinarily durable in continuous operation. Very little heat is lost by the entire system and maintenance intervals are usually longer than twelve months even when operated continuously under difficult conditions. The CBWH and CIWH series are the world's only block-type pumps with an air-cooled shaft seal that pump hot water above 183 °C/361 °F without external cooling. Due to their maximum oil temperature of 400 °C/752 °F, CTWH, CBWH, and CIWH 350°C/662 °F are also ideal for modern applications like solar power stations.

### Highly available

Design details ensure high reliability and safety. These pumps are unrivalled in mechanical strength. Both the seals and the bearing are cooled efficiently and protected from dry running. The mechanical seal's weight-bearing capacity and service life are extraordinarily high thanks to a special bearing geometry and tilting suspension.

### Safe

Safety gland packing, minimal axial thrust, antifriction bearings with a long service life, optimal quench and seals, and a double cardanic coupling for special applications increase the safety of often critical heat-transfer applications.

### Highly variable and individualized

You choose from six variations: coupling, block, and inline versions each with two pressure stages (for PN16 and pump dimensions according to EN 733 or for PN 25 and dimensions according to ISO 2858). Two bearing-seal combinations are available: an unrelieved all-round mechanical seal with a carbon-antimony bearing or a relieved heavy duty seal with a silicon carbide plain bearing.



Depending on the environmental conditions, you can choose the coupling version (NTWH/CTWH), block version (NBWH/CBWH), or inline version (NIWH/CIWH).

### Maximum performance data ALLHEAT®

	NTWH	NBWH	NIWH	CTWH	CBWH	CIWH	
Q	1,250 / 5,504	270 / 1,189	220 / 969	1,450 / 6,385	240 / 1,057	105 / 462	m <sup>3</sup> /h / gpm
H	100 / 328	92 / 302	92 / 302	100 / 328	63 / 207	58 / 190	m / ft
p <sub>d</sub>	16 / 232	16 / 232	16 / 232	25 / 363	25 / 363	25 / 363	bar / psi
t	183 / 361 (hot water), 350 / 662 (oil)			207 / 405 (hot w.), 400 / 752 (oil)		350 / 662	°C / °F

## ALLHEAT® 1000 SERIES: FOR HIGH PERFORMANCE

### COMPACT AND LOW MAINTENANCE PUMPS FOR THERMAL OILS

High-performance centrifugal pumps are specially designed for pumping thermal oils in heat-transfer systems at up to 400 °C/ 752 °F and across great distances and/or in large volumes. For example, at 50 Hz and a speed of 2,900 1/min, it achieves a capacity of 1,000 m<sup>3</sup>/h/4,403 gpm and a delivery head of 80 m/262 ft. The maximum capacity of the ALLHEAT® 1000 is 1,450 m<sup>3</sup>/h/6,385 gpm, maximum delivery head is 105 m/344 ft, and maximum working pressure is 25 bar/ 363 psi.

Like all ALLHEAT® pumps, ALLHEAT® 1000 does not require external cooling. It is characterized by a variety of innovative features. Instead of using larger-diameter impellers, the pump is specifically designed to achieve its performance characteristics at higher speeds of up to 2,900 1/min.

The resulting compact process design is easy to install. This keeps the operator's investment costs and total cost of ownership (TCO) low.

Like all other ALLHEAT® pumps, the ALLHEAT® 1000 is very reliable with extremely long maintenance intervals. The seal chamber is specially designed so that any gas ring appearing around the seal will be stripped off. Released gas collects in a stabilized zone and is vented without attacking the sliding surfaces of the gasket. The plain bearing's special lubrication geometry ensures optimal lubrication at extremely high loads and makes the bearing insensitive to contamination in the liquid.

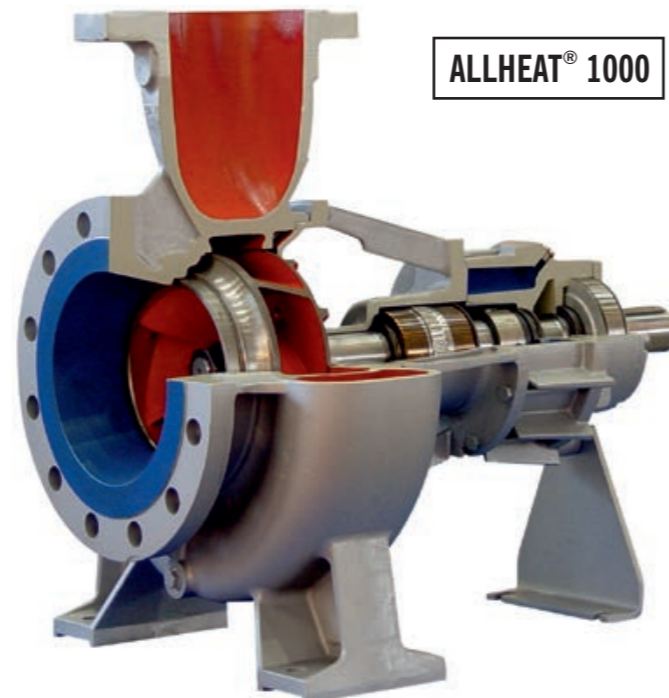

## INDEPENDENT OF EXTERNAL POWER SUPPLIES

### DISTURBANCE-FREE OPERATION EVEN IF THE POWER FAILS

Hatz diesel engines ensure that the pump has a continuous power supply even during power failures. As well as connection to a pump of the "NTT" series (shown in the figure), all other pumps can be operated in this manner as well.

The diesel units start as soon as the power supply fails. An automatic power-failure device ensures a rapid start. The large 60L fuel tank is adequate for regular usage without frequent refilling.

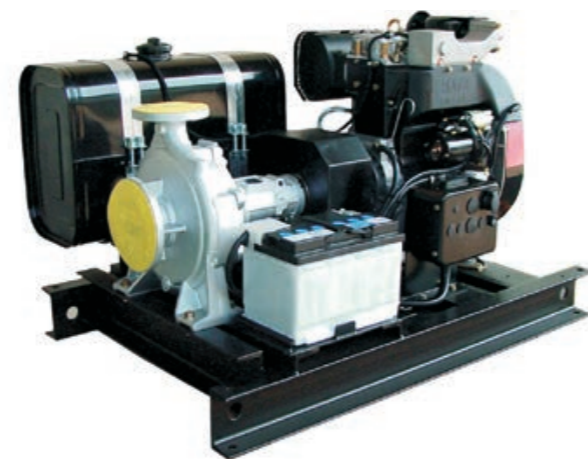

NTT with emergency power unit

## FOR WATER AND CHEMICALS

### STANDARDIZED WATER PUMP PROGRAM (NT) AND SEALS ACCORDING TO CHEMICAL SPECIFICATIONS (CWH)

The three series of standardized pumps (NT, NI, and NB) are ideal for pumping only hot water at 100 °C/212 °F or less. They merge reliability with low lifecycle costs and an attractive initial investment. When equipped with a special shaft seal, these series are also suitable for hot water up to 140 °C/284 °F. The pumps are available with a bearing bracket (NT), as a directly-coupled block (NB), and in an inline version (NI). The NB and NI versions can be installed vertically and horizontally.

NT is delivered with a separately coupled motor and with a volute casing on a base plate. The best choice for your particular situation will depend on how your pipes are laid out and how much space is available. All three design types are also available in two-stage versions with the same external dimensions. The two-stage version is ideal when a relatively small flow rate is needed but simultaneously a high delivery head, good efficiency, and low NPSH values.

The pumping capacity significantly exceeds the standardized rated power. Fifteen additional sizes round out the EN 733 performance range.

#### Specially for chemical applications

ALLHEAT® CWH pumps are specially designed for chemical plants and chemical applications, particularly for circulating heat-carrier oil or hot water in primary closed loops of large heat-carrier distribution systems. The hydraulics of ALLHEAT® CWH are dimensioned for high delivery heads with capacities between 500/2,202 and 1,200 m<sup>3</sup>/h/5,284 gpm. For this reason, this pump is the right choice when you need to supply complex heat-carrier circulation systems with many secondary closed loops.

The double-action, cartridge-type mechanical seal system complies with specifications of the textile fiber and chemical industries. Together with the specially developed thermosyphonic circulation system for the buffering fluid, it provides the highest possible security against leaks.

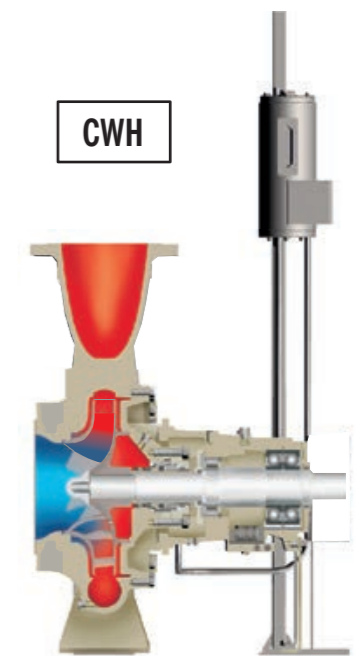
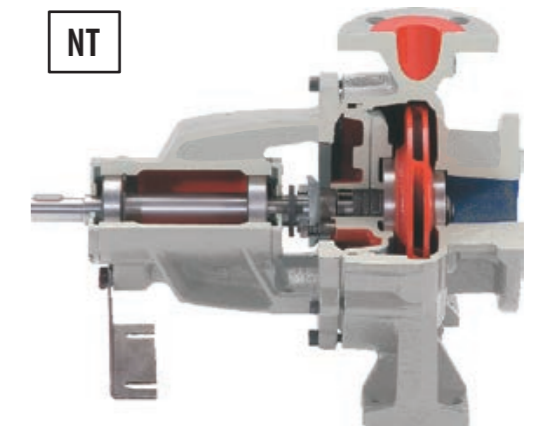

#### Maximum performance data of standard water pumps and chemical pumps

	NT	NI	NB	CWH	
Q	2,300 / 10,128	380 / 1,673	480 / 2,114	1,200 / 5,284	m <sup>3</sup> /h / gpm
H	145 / 476	140 / 459	145 / 476	97 / 318	m / ft
p <sub>d</sub>	10/16 / 145/232	10/16 / 145/232	10/16 / 145/232	25 / 363	bar / psi
t	140 / 284	140 / 284	140 / 284	350 / 662	°C / °F

# ALLMAG®: HERMETICALLY SEALED CENTRIFUGAL PUMPS WITH MAGNETIC DRIVE

WITH THE ALLMAG PUMPS YOU CAN SAFELY MOVE TOXIC, ENVIRONMENTALLY HAZARDOUS, AND ODOROUS HEAT-CARRIER LIQUIDS

## THE BENEFITS:

### Economical

Standardized parts and a small number of components keep stocks and replacement parts costs low.

### Operational safety

Large silicon-carbide bearing and symmetrical impeller lower axial and radial loads and distributes forces onto the bearing as efficiently as possible.

### Maintenance-free

Hydrodynamic lubrication of the bearing permits virtually unlimited service life even with low-viscosity liquids; the bearing is incorporated into patented tolerance rings.

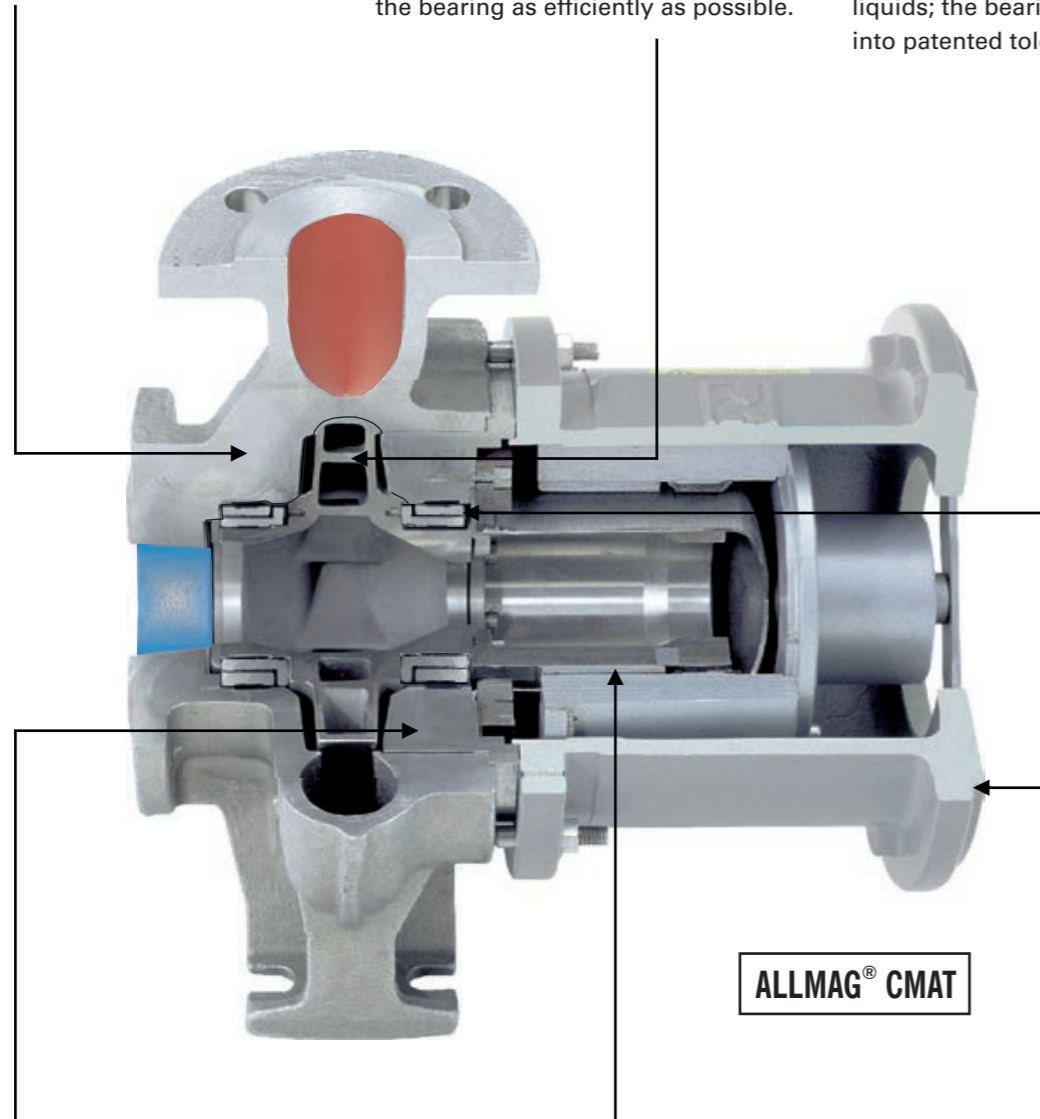

**ALLMAG® CMAT**  
Excellent price/  
performance ratio,  
patented pump  
concept for difficult  
liquids, block con-  
struction, horizontal  
or vertical instal-  
lation.

### Wear-resistant

Patented guidance of the rinse flow through the SiC plain bearing provides large tolerance for solid particles as well as security against leaks and protection for the can. Shaftless design results in short straight-line rinse flow that eliminates dead spaces and deposits in the rinse flow.

### Saves energy

Optimized cooling of the can and low heat losses because the pumped liquid absorbs lost heat.

### Robustness

Insensitive to external influences and disturbance-free absorption of line forces thanks to a special housing design with a robust lantern.

All ALLMAG® pumps are emissions-free and combine practical advances with the latest technologies and materials. The results are a high degree of operational safety and a long service life. Since the magnetic coupling eliminates all parts that are normally subject to wear, the need for maintenance and replacement parts is also reduced. The connection dimensions comply with DIN EN 22858/ISO 2858, making it easy to integrate the pumps into existing systems.

The magnetic components are specially designed to minimize heat losses to the outside. Compared to other magnetically-coupled pumps, ALLMAG® pumps radiate very little heat externally, making them the ideal solution in systems meant to transfer heat.

### Type CMAT/CMIT: Economical and innovative

With pump types CMAT (block version) and CMIT (inline version) you can economically and safely cover a variety of operational conditions. This innovative design contains no shaft. The benefits are outstanding heat dissipation, a high tolerance against solids in the liquid, gentle pumping action and minimal stress on the bearing.

### Model CNH-ML: Heavy duty and variable

Baseplate versions of the high-performance CNH-ML pumps are designed to handle previously insurmountable pumping challenges. These pumps are ready to take on extreme requirements. Their extraordinary insensitivity makes them reliable performers under the most difficult conditions, including, for example, low viscosities, stagnating liquids, and liquids contaminated with large amounts of solid particles.

### Individual solutions based on the successful CNH-ML standard

You choose the right supplemental units for your requirements:

- External flushing for sticky liquids or liquids that tend to stagnate
- Electric heating
- Leak monitoring with level sensor
- Torque monitor
- Version for pumped liquids with up to five percent solid particles
- Accessories completely according to the customer's specifications

### Maximum performance data ALLHEAT®

	CMAT	CMIT	CNH-ML	
<b>Q</b>	105 / 462	105 / 462	300 / 1,321	m <sup>3</sup> /h / gpm
<b>H</b>	55 / 180	55 / 180	145 / 476	m / ft
<b>p<sub>d</sub></b>	16 / 232	16 / 232	16/25 / 232/363	bar / psi
<b>t</b>	183 / 361 (hot water)		207 / 405 (hot water)	°C / °F
<b>t</b>	350 / 662 (oil)		350 / 662 (oil)	°C / °F

# ALLFUEL: VARIABLE SEALING DESIGN FOR DEPENDABLE OIL DELIVERY

SCREW PUMPS THAT MEET THE MOST STRINGENT REGULATIONS FOR ENVIRONMENTAL PROTECTION AND SAFETY

## THE BENEFITS:

### The best possible control

The vacuum gauge provides continuous information about the filter condition.

### No-interrupt maintenance

The non-return valve in the twin unit allows continuous operation even when removing and maintaining one of the pumps.

### Safety and reliability

When combined with an emergency-off controller, ALLSEAL gives the operator advance notice of the pump's condition and can prevent serious consequences associated with pump failures.

### Rapid maintenance

Vertical filter installation enables filter replacement without draining oil.

### Long service life and reliability

Thanks to the inside-out filter flow and a magnet in the floor of the filter, dirt and metal chips collect safely inside the filter.

### Good suction performance

Large filter surfaces ensure very good suction performance and extended maintenance intervals.

### Low-noise operation

The special shape of the threaded flanks produces virtually pulsation-free and quiet pumping action.

### Temperature insensitivity

Optional heating permits safe starting even when the ambient temperature is low.

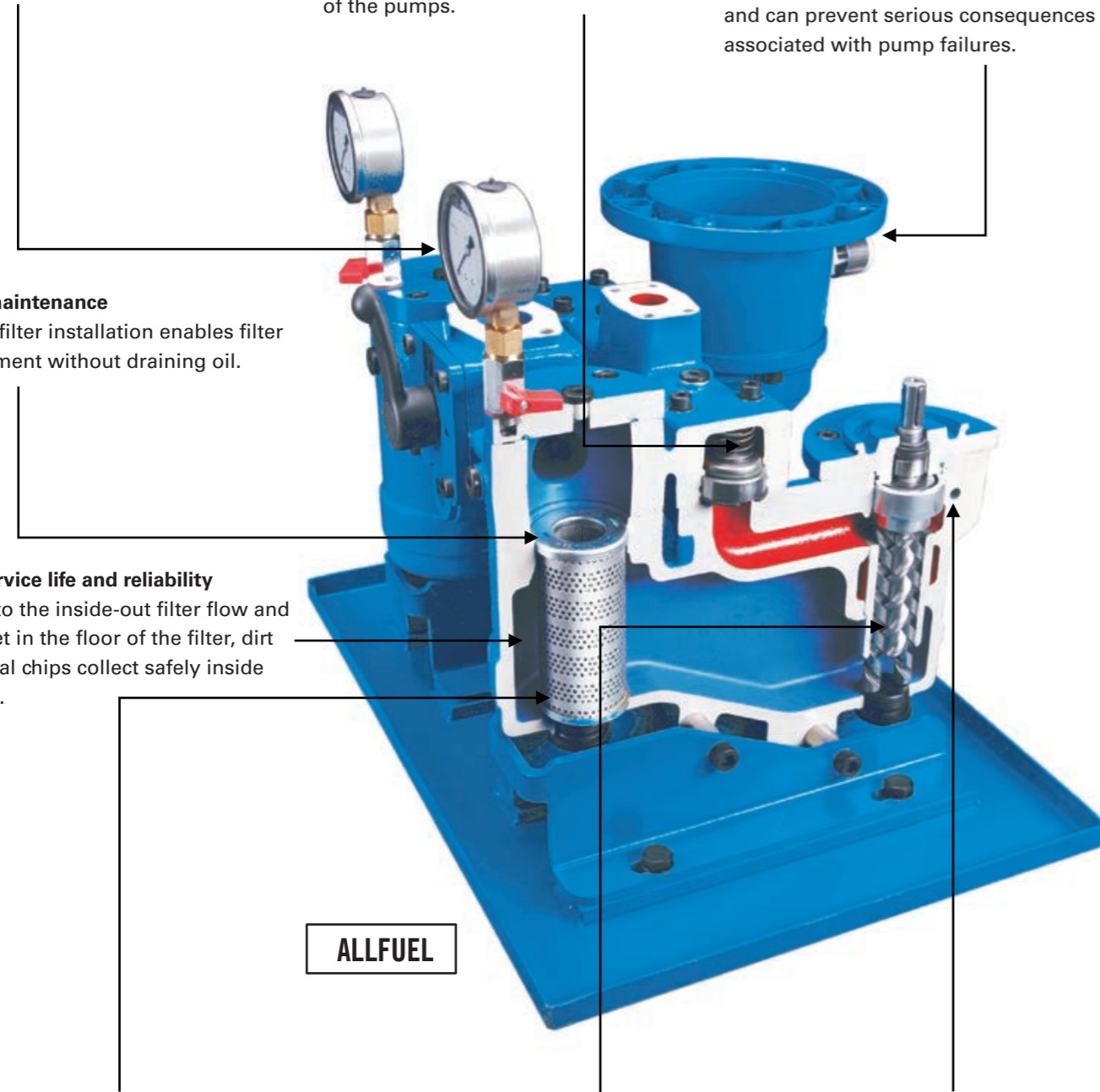

When you choose a screw pump from the ALLFUEL family, you get a pump unit that efficiently and reliably pumps all mineral-based and synthetic oils. These pumps work with virtually no noise and pulsation, they are self-priming, and need only a small amount of space. ALLFUEL pumps are ideal when you need to supply burner systems with fuel or must fill or empty heat-carrier oil systems.

### A safe solution for critical systems

Allweiler® developed an innovative sealing design in response to elevated safety and environmental requirements. Depending on your requirements, you may choose to equip the ALLFUEL series with the new ALLSEAL leak-collection and -detection system in addition to the regular mechanical seal. ALLSEAL's opto-electronic sensor will give you advance notice that the mechanical seal requires maintenance. When combined with an emergency-stop switch, ALLSEAL can prevent serious pump failures and related high expenses.

### Overview of the benefits:

- Continuous monitoring of the mechanical seal
- Early detection of unusual leaks
- Safe handling of critical fluids
- Compliance with stringent environmental standards
- Longer pump service life

A hermetically-sealed magnetic coupling (ALLFUEL AFM series) is an alternative to ALLSEAL and ensures a complete absence of leaks for even greater safety and reliability. The redundant twin units (AFM-T series) for critical systems can be switched and replaced without interrupting normal operations. The optional radial screen filter (AFM-F series) ensures disturbance-free pumping of even contaminated liquids.

### ALLFUEL: Two versions:

- “T” : Low-pressure “Transfer” pumps up to 6 bar/87 psi.
- “I” : “Injection” pumps for medium pressure up to 40 bar/580 psi.



### Maximum performance data of ALLFUEL

	AFI	AFT	AFM	
Q	112 / 424	108 / 409	112 / 424	l/min / gpm
t	150 / 302	150 / 302	150 / 302	°C / °F
p <sub>s</sub>	6 / 87	5 / 73	25 / 363	bar/ psi
p <sub>d</sub>	40 / 580	6 / 87	40 / 580	bar/ psi
V	1-750	1.4-380	1-3,000	mm <sup>2</sup> /s



## ALLHEAT® : REDEFINING EFFICIENCY OF HEAT TRANSFER APPLICATIONS

ALLHEAT® combines high engineering knowledge with application expertise that allows us to optimize your heat transfer applications.

Our commitment to you also includes unmatched understanding of your business challenges and global responsiveness to your needs. Our global team of experts ensure you have what you need when you need it – we are committed to being a partner in your success by redefining what's possible for you and your customers.

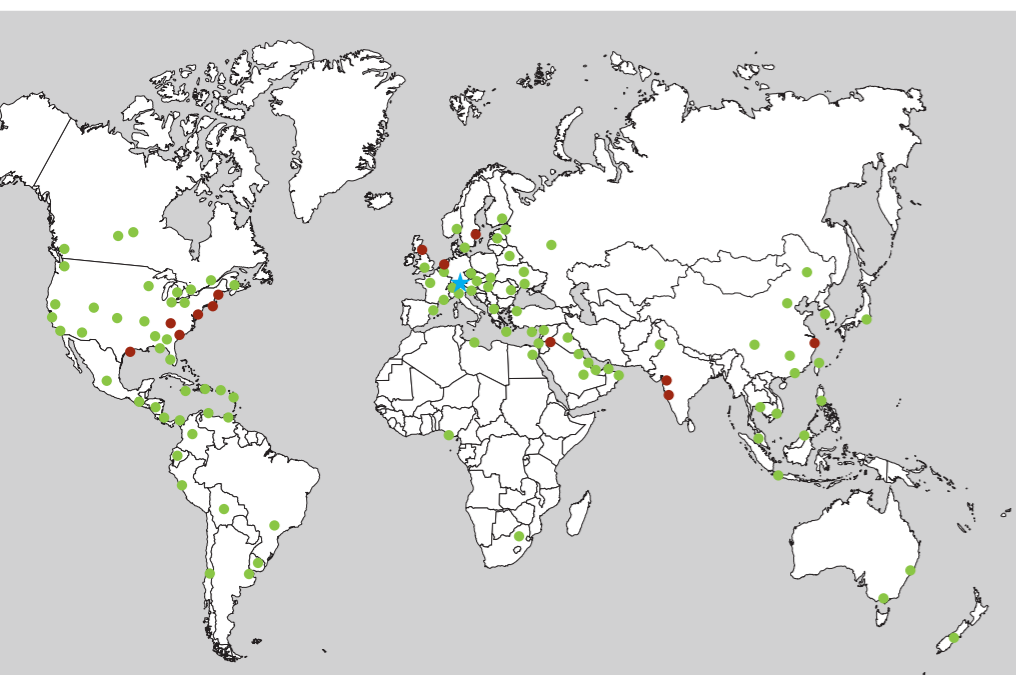

### REDEFINING WHAT'S POSSIBLE

CIRCOR has a global network of sales, production, and service capabilities to ensure that our customers receive competent and optimal support.

- ★ Headquarters
- Regional production and consultation centers
- Global sales network

### CIRCOR

ALLWEILER GmbH  
Allweilerstr. 1  
78315 Radolfzell  
Germany

1710 Airport Road  
Monroe, NC 28110  
USA

Unit 1803, 18/F  
Clifford Centre  
778 Cheung Sha Wan Road  
Lai Chi Kok, Kowloon  
Hong Kong

Unit 804,  
Venture International Park  
Building B  
No. 2679 Hechuan Road  
Shanghai 201103  
China

Tel. +49 7732 86 0

Tel. +1 704 289 65 11

Tel. +852 3473 2700

Tel. +86 21 6248 1395

[www.circorpt.com](http://www.circorpt.com)



Power & Industry Products & Services

ALLWEILER® HOUTTUIN™ IMO® WARREN®

CIRCOR, ALLWEILER, IMO, TUSHACO and WARREN are registered trademarks and HOUTTUIN is a trademark of CIRCOR or its subsidiaries in the U.S. and/or other countries. (c) 2018, CIRCOR. All rights reserved. 796566 - 2018.04





[www.circorpt.com](http://www.circorpt.com)

---

COMMERCIAL MARINE

DEFENSE

OIL & GAS

POWER & INDUSTRY

RELIABILITY SERVICES