

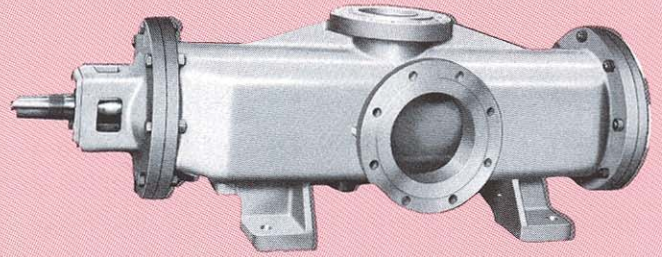

**300-800 GPM Up to 700 PSI**



## **Model T324N**

IMO Model T324N pumps are positive displacement, double-ended rotary, screw-type pumps designed and engineered for excellent suction capability over a wide range of fluid viscosities. Flow rates (300 to 800 GPM) are proportional to rotating speed when the pump is operated within the recommended pressure range (up to 700 PSI). The self-priming design permits both evacuation of air filled inlet lines and repriming if suction is lost.

The unique IMO design—only three moving parts—is the key to the Model T324N pump performance. A precision bored housing encases the driven screw (power rotor) and intermeshing sealing screws (idler rotors). The accurately machined idler rotors conform perfectly to the threads of the power rotor and to the housing bores, confining the fluid in a succession of closures or cavities. As the screws rotate, the fluid is moved axially from the inlet port to the outlet port in a continuous, uniform flow. This uniform axial flow results in a minimum of fluid pulsation and extremely quiet operation.

The rotating idler rotors generate a hydrodynamic film of fluid which supports the idlers in the housing bores and prohibits wearing contact. The strength

of this film is based on fluid viscosity, pump pressure and speed. As pressure requirements increase, the hydrodynamic film can be strengthened by increasing viscosity or speed. Both the flow rate and pressure capability of the IMO pump increase with speed; thus higher speeds generally result in better performance and longer life.

The symmetrical arrangement of the rotors (screws) eliminates the need for bearings to absorb radial loads. Axial loads are balanced hydraulically within the pump.

Model T324N pumps are offered in two rotor sizes for foot mounted configurations. A variety of construction materials are available to meet operating conditions and job specifications. Complete pump/driver assemblies can be provided as required.

The simple design of the Model T324N pump permits fast, easy installation, low maintenance, and ease of repair. All wearing parts are completely replaceable. Periodic inspections can be made without removing the pump, and routine maintenance can be performed without disturbing system piping.

## **Applications**

Model T324N pumps are designed to meet the requirements for a wide variety of applications including highly viscous fluids, hydraulic, lubricating, seal, distillate, residual, fuel and crude oils. These units have been widely utilized in refineries, chemical and petrochemical plants, mechanical transmissions, lubricating systems and high flow pump boosting stations—wherever high performance and reliability in a rugged design are required.

Typical applications are:

**Transfer** of polymers, glycols, vegetable oils,

paraffins, molasses, grease, paint, asphalt and other highly viscous and/or shear sensitive type fluids in pipelines and process systems.

**Loading and Unloading** of lube, fuel, bunker, crude, waste and similar type oils in refineries, factories, storage and settling tanks.

**Lubrication** of diesel engines, gas turbines, steam turbines, compressors, transmission gears, large centrifugal pumps, power recovery turbo expanders and other rotating machinery.



## ***Model T324N Specifications and Features***

<b>CASE</b> .....	High shock capacity ductile (nodular) iron. Optional steel case available.
<b>ROTOR HOUSINGS</b> .....	Bronze—Standard Bimetal—Nonstandard
<b>POWER &amp; IDLER ROTORS</b> . . .	Hardened alloy steel.
<b>SHAFT SEAL</b> .....	Type B—Buna N bellows mechanical carbon face type seal with cast iron seat—recommended for distillate oils.  Type ZT—Positive drive mechanical seal with tungsten carbide seat and carbon face—recommended for residual and crude oils.
<b>BEARING</b> .....	External grease packed deep groove ball type.
<b>PRESSURE</b> .....	700 PSIG. Consult IMO for higher pressures.
<b>SPEED LIMITS</b> .....	Maximum speed is 2300 RPM. All speeds above 1800 RPM must be factory approved.
<b>VISCOSITY</b> .....	Minimum is 2.0 cst ( $\approx$ 33 SSU). See tables for minimum viscosities for specific speeds and pressures.  Maximum for Type B seals is 3000 SSU. Above 3000 SSU, use Type ZT seals—consider cold startup condition.
<b>TEMPERATURE</b> .....	Type B seal construction: 0–180°F Type ZT seal construction: 0–250°F
<b>INLET</b> .....	65 PSIG maximum (special design to 400 PSIG available) Consult tables for minimum required inlet pressure
<b>ROTATION</b> .....	Clockwise rotation only, facing pump shaft
<b>DRIVE</b> .....	Direct only
<b>FILTRATION</b> .....	Inlet strainers are required to keep maximum abrasives out of the pump but they must be selected with consultation of strainer vendor to prevent pump starvation. Normally, 60 mesh for light and $\frac{1}{8}$ "– $\frac{3}{16}$ " openings for heavy oils are recommended.
<b>MOUNTING</b> .....	Foot mounted design only.
<b>WR<sup>2</sup> APPROXIMATE</b> .....	400P & 400 Sizes 322 lb.—ln <sup>2</sup>



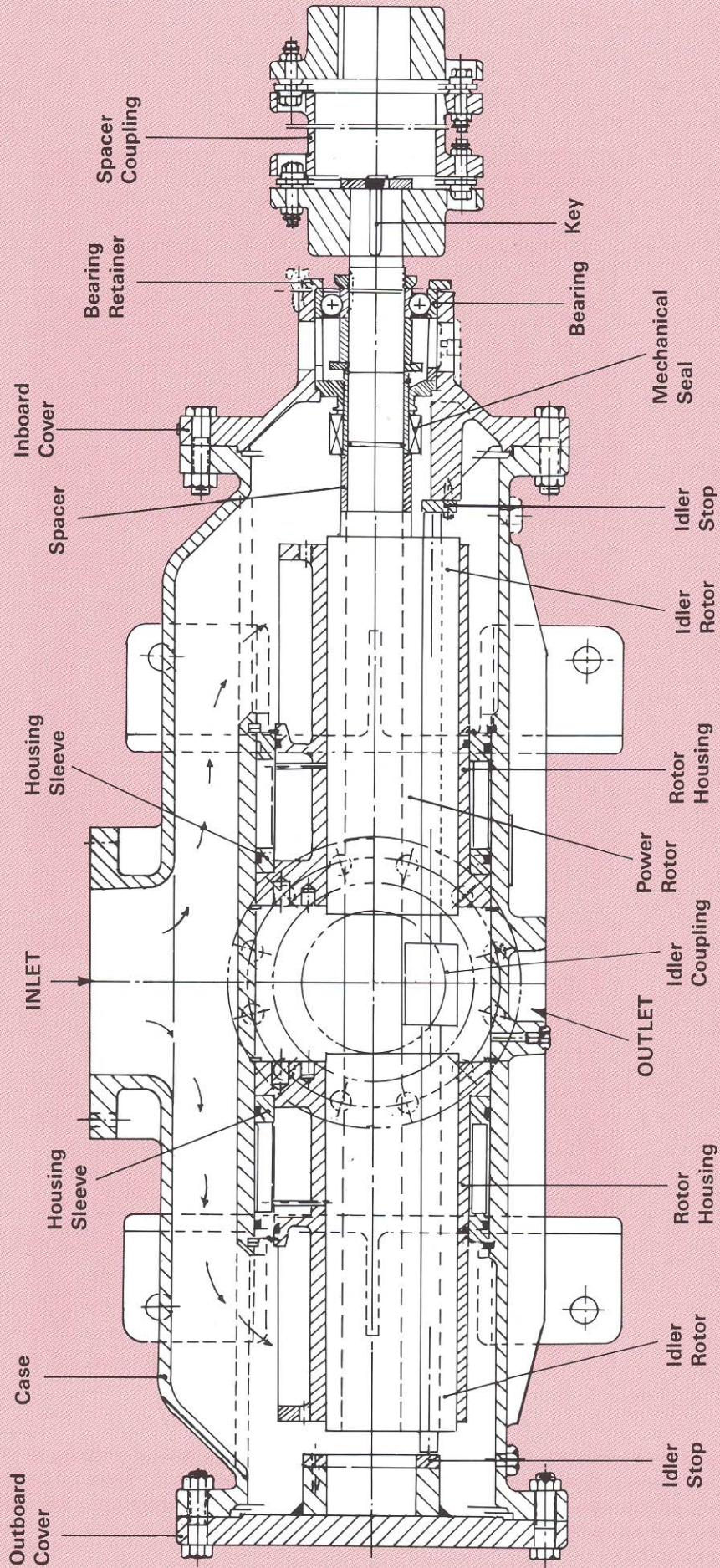

*Typical T324N Assembly (Bronze Construction)*



# Performance Tables

## T324N-400P

Speed 1750 RPM														
	Viscosity SSU	Pressure — PSI								Net Inlet Pressure Required PSI *				
		200	250	300	350	400	500	600	700					
GPM	33	569	554	541	—	—	—	—	—	—				
	40	580	567	555	544	534	—	—	—					
	60	601	590	580	571	563	548	534	—					
	100	621	613	605	598	592	580	569	560					
	200	641	635	630	625	621	612	605	598					
	1000	669	666	664	662	660	656	653	649					
BHP	200	93.2	113	133	153	173	214	254	294		6.7			
	500	102	122	143	163	183	223	264	304	7.8				
	1000	114	134	154	175	195	235	275	316	8.8				
	3000	147	167	187	207	227	268	308	349	12.7				
	5000	171	192	212	232	252	293	333	373	16.0				
	7000	193	213	233	253	273	314	354	394	21.0				

Speed 1150 RPM														
	Viscosity SSU	Pressure — PSI								Net Inlet Pressure Required PSI *				
		200	250	300	350	400	500	600	700					
GPM	33	332	317	304	—	—	—	—	—	—				
	40	343	330	318	307	297	—	—	—					
	60	363	353	343	334	326	310	397	—					
	100	384	376	368	361	355	343	332	322					
	200	404	398	393	388	384	375	368	361					
	1000	432	429	427	425	423	419	415	412					
BHP	200	58.5	71.7	85.0	98.3	111	138	164	191		4.9			
	500	62.6	75.9	89.1	102	115	142	168	195	5.4				
	1000	67.8	81.0	94.3	107	120	147	173	200	5.4				
	3000	82.1	95.3	108	121	135	161	188	214	6.4				
	5000	92.9	106	119	132	145	172	198	225	7.3				
	7000	102	115	128	141	155	181	208	234	8.8				
10000	114	127	140	154	167	193	220	246	10.0					

Speed 870 RPM														
	Viscosity SSU	Pressure — PSI								Net Inlet Pressure Required PSI *				
		200	250	300	350	400	500	600	700					
GPM	33	221	206	—	—	—	—	—	—	—				
	40	232	219	207	196	—	—	—	—					
	60	253	242	232	223	215	200	—	—					
	100	273	265	257	250	244	232	222	212					
	200	294	288	282	277	273	264	257	250					
	1000	321	318	316	314	312	308	305	302					
BHP	200	43.3	53.3	63.3	73.4	83.4	103	123	143		4.9			
	500	45.7	55.7	65.7	75.7	85.8	105	125	146	4.9				
	1000	48.6	58.6	68.7	78.7	88.7	108	128	148	4.9				
	3000	56.9	66.9	76.9	87.0	97.0	117	137	157	5.4				
	5000	63.1	73.1	83.1	93.2	103	123	143	163	5.8				
	7000	68.4	78.4	88.5	98.5	108	128	148	168	6.4				
10000	75.4	85.4	95.4	105	115	135	155	176	7.3					

\*Net inlet pressure required is the minimum allowable difference between the absolute pressure at the inlet port and the liquid's vapor pressure. When expressed in feet of liquid, net inlet pressure is the same as net positive suction head (NPSH).

1. Maximum pressure allowed is the pressure directly above the last entry in a specified viscosity row.
2. Do not interpolate maximum allowable pressure for intermediate viscosities.
3. For lower viscosity, consult IMO.



# Performance Tables

## T324N-400

Speed 1750 RPM										
Viscosity SSU	Pressure—PSI									
	200	250	300	350	400	500	600	700	Net Inlet Pressure Required PSI*	
GPM	33	721	705	—	—	—	—	—		—
	40	735	720	706	694	—	—	—	—	
	60	759	747	735	725	715	698	682	—	
	100	783	773	764	756	749	735	723	712	
	200	807	800	794	788	783	773	764	756	
BHP	1000	838	835	833	830	828	823	820	816	9.8
	200	113	138	163	189	214	264	315	365	
	500	122	148	173	198	223	274	324	375	
	1000	134	159	185	210	235	285	336	386	
	3000	167	192	217	243	268	318	369	419	25.0

Speed 1150 RPM										
Viscosity SSU	Pressure—PSI									
	200	250	300	350	400	500	600	700	Net Inlet Pressure Required PSI*	
GPM	33	425	408	—	—	—	—	—		—
	40	439	424	410	397	—	—	—	—	
	60	463	450	439	429	419	401	385	—	
	100	486	477	468	460	452	439	427	415	
	200	510	503	497	491	486	477	468	460	
BHP	1000	542	539	536	534	531	527	523	520	5.9
	200	71.7	88.3	104	121	138	171	204	237	
	500	75.9	92.5	109	125	142	175	208	241	
	1000	81.0	97.6	114	130	147	180	213	247	
	3000	95.3	111	128	145	161	194	227	261	
	5000	106	122	139	155	172	205	238	271	
	7000	115	131	148	165	181	214	247	281	
10000	127	144	160	177	193	226	260	293	18.0	

Speed 870 RPM										
Viscosity SSU	Pressure—PSI									
	200	250	300	350	400	500	600	700	Net Inlet Pressure Required PSI*	
GPM	33	287	—	—	—	—	—	—		—
	40	301	285	272	—	—	—	—	—	
	60	324	312	301	290	281	263	—	—	
	100	348	338	330	322	314	301	288	277	
	200	372	365	359	353	348	338	330	322	
BHP	1000	404	401	398	395	393	389	385	381	4.9
	200	53.3	65.8	78.4	90.9	103	128	153	178	
	500	55.7	68.2	80.8	93.3	105	130	156	181	
	1000	58.6	71.2	83.7	96.8	108	133	159	184	
	3000	66.9	79.4	92.0	104	117	142	167	192	
	5000	73.1	85.7	98.2	110	123	148	173	198	
	7000	78.4	91.0	103	116	128	153	178	203	8.3
	10000	85.4	98.0	110	123	135	160	185	210	9.7

\*Net inlet pressure required is the minimum allowable difference between the absolute pressure at the inlet port and the liquid's vapor pressure. When expressed in feet of liquid, net inlet pressure is the same as net positive suction head (NPSH).

1. Maximum pressure allowed is the pressure directly above the last entry in a specified viscosity row.
2. Do not interpolate maximum allowable pressure for intermediate viscosities.
3. For lower viscosity, consult IMO.

# Series T324N Pump Dimensions

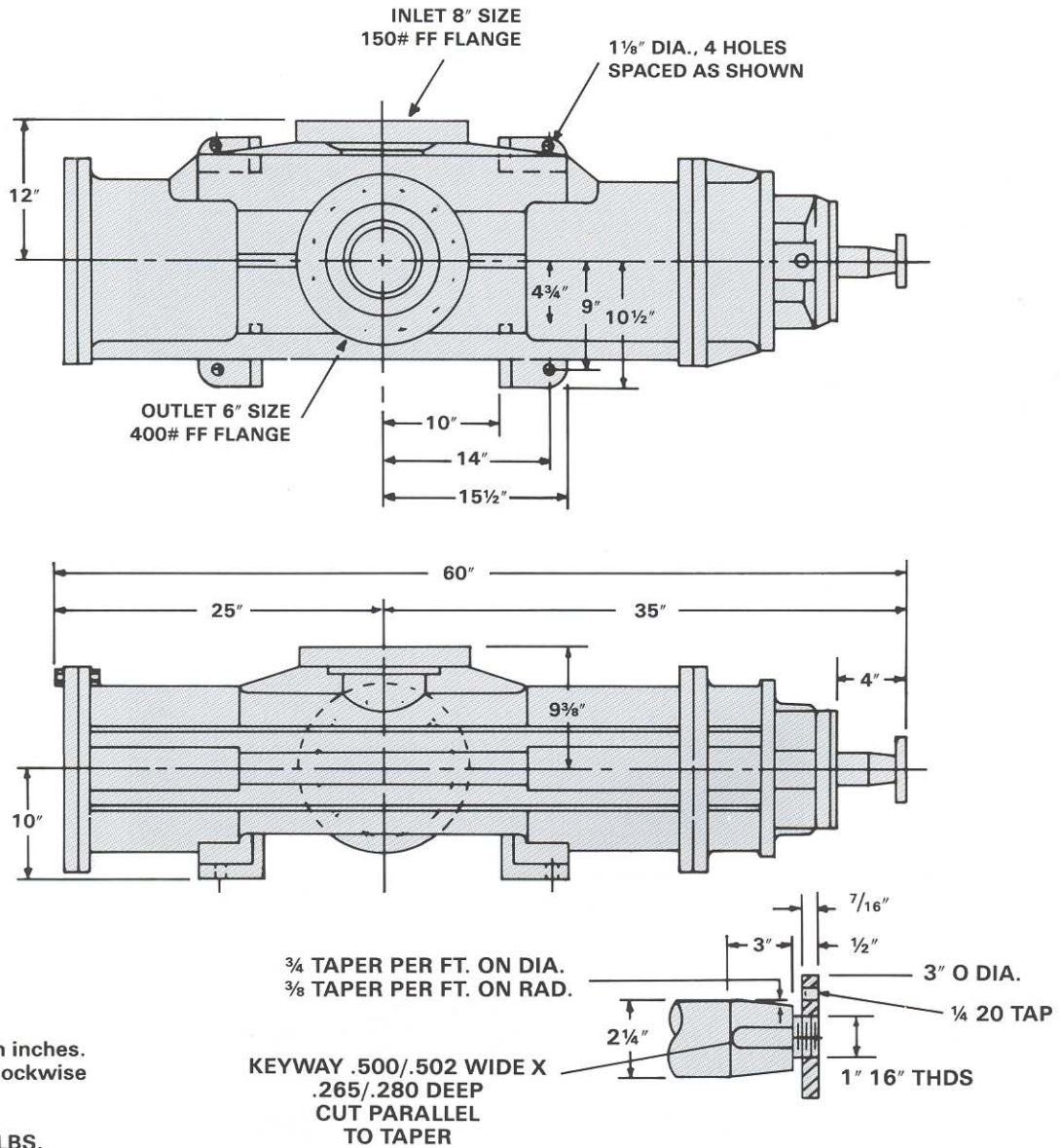

All dimensions are in inches.  
Standard rotation: clockwise

WEIGHT 2100 LBS.

Contact factory for steel construction details.

## T324N—400 and 400P

CUSTOMER	CUSTOMER ORDER	IMO ORDER	T324N
CERTIFIED BY	DATE	OFFICE	OFFICE NO.

IMO PUMP DIVISION



## Typical Pump/Driver Arrangements

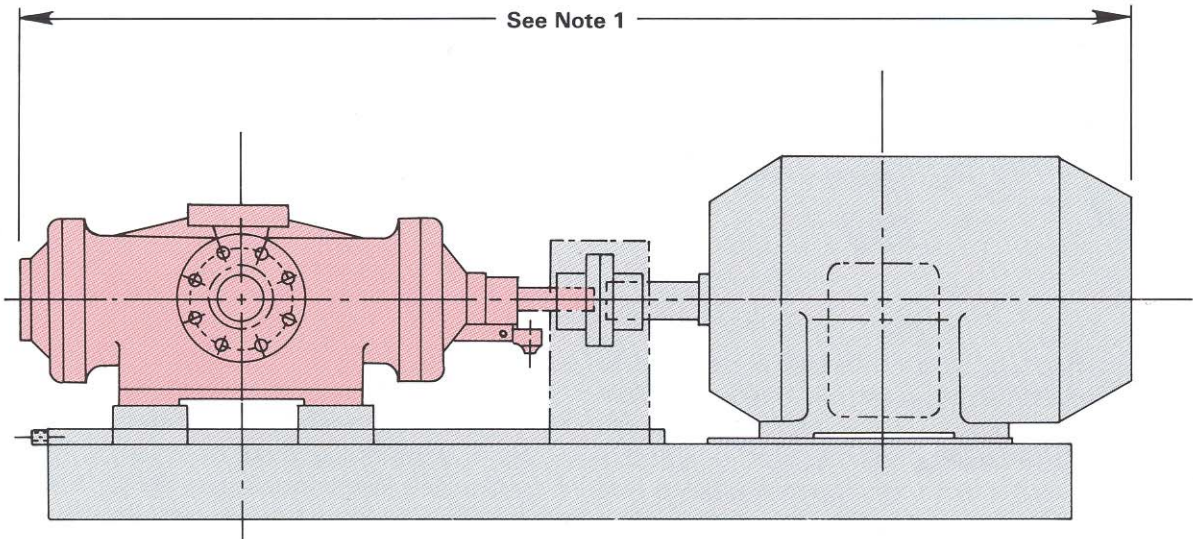

**T324N HORIZONTAL FOOT MOUNTED PUMP/MOTOR ASSEMBLY**

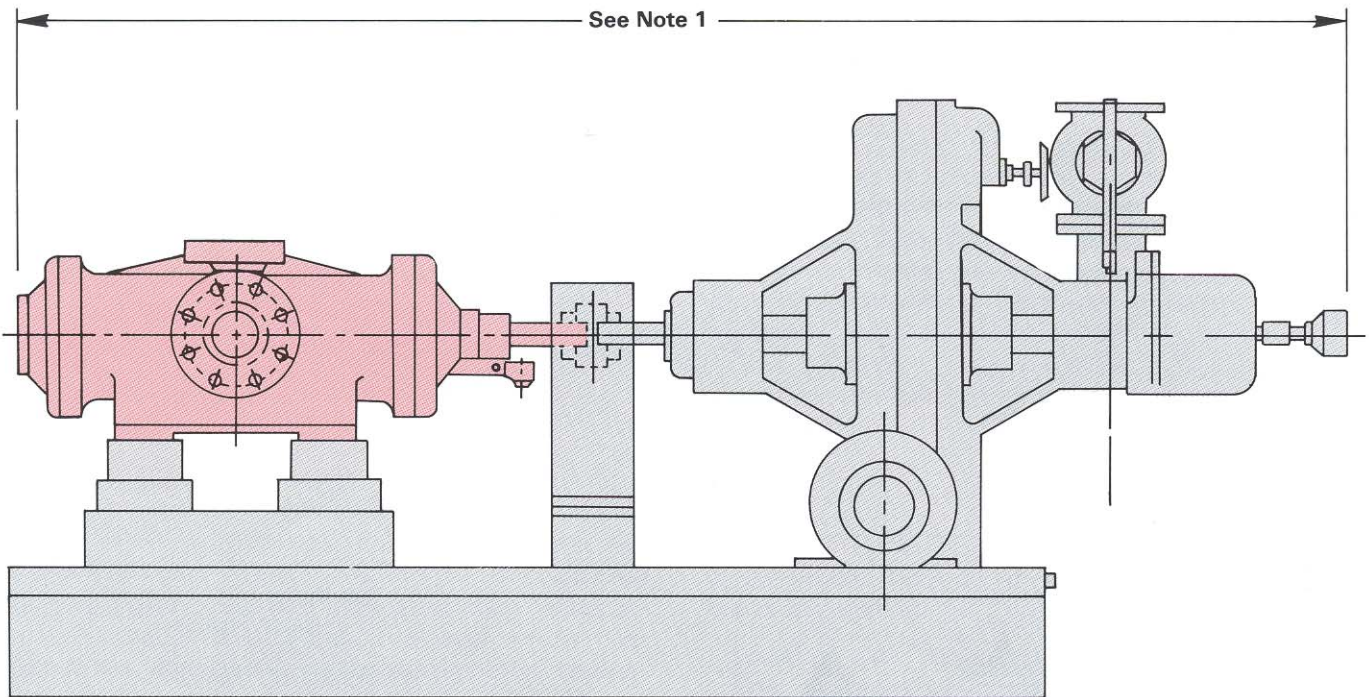

**T324N HORIZONTAL FOOT MOUNTED PUMP/TURBINE ASSEMBLY**

### NOTES:

1. Pump/driver assemblies with OSHA type coupling guard and shaft coupling factory mounted on a steel baseplate (with or without driprim) are available upon request.
2. For arrangements or variations not shown, contact IMO.

# Typical T324N Nomenclature

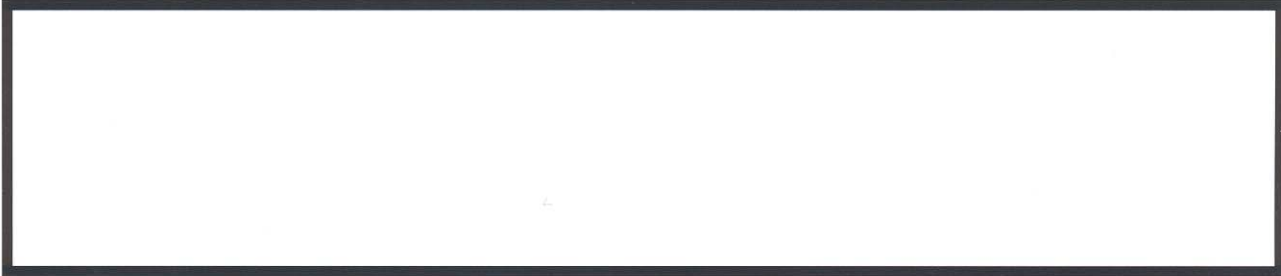
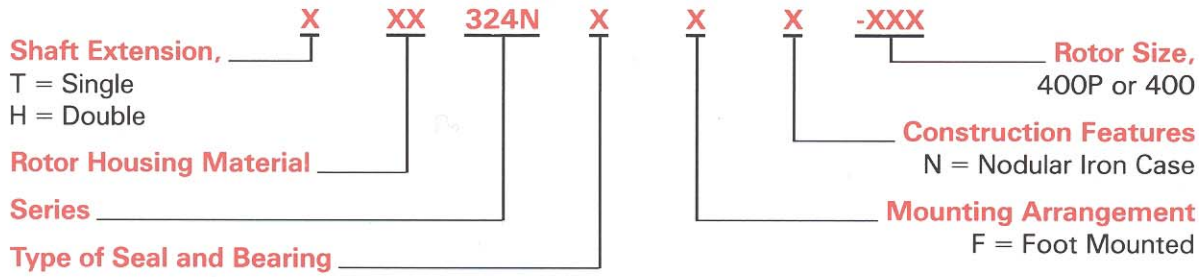

For additional sales and service information, contact your local IMO Sales Representative.



Quality Management System



**Imo Pump**  
 1710 Airport Road  
 PO Box 5020  
 Monroe, NC USA  
 28111.5020

tel 704.289.6511  
 fax 704.289.9273  
 e-mail Imo.Pump@ColfaxCorp.com  
 web WWW.IMO-PUMP.COM