



LESLIE
CONTROLS, INC.

A subsidiary of CIRCOR International, Inc.

12501 Telecom Drive, Tampa Florida 33637

**Installation, Operating and
Maintenance Instructions
PARTS LIST**

**90/4.5.1
Rev. 4**

**CONSTANTEMP
LOW PRESSURE STEAM-WATER HEATERS**

TABLE OF CONTENTS

SECTION I – INSTALLATION..... 2

SECTION II – START-UP..... 2

SECTION III – MAINTENANCE..... 3

SECTION IV – TROUBLE-SHOOTING GUIDE..... 4

PARTS LIST..... 8-19

RECIRCULATION SWITCH INSTALLATION..... 20

ILLUSTRATION INDEX

DRAWING, DIMENSIONS, TYPICAL INSTALLATIONS AND MISCELLANEOUS DATA

Figure 1 – Control Valve Complete..... 3

Figure 2 – Gain Control Adjustment Curve Diagram..... 4

Figure 3 – Actuator Assembly..... 5

Figure 4 – Valve Plug Guide..... 5

Figure 5 – Temperature Adjustor..... 5

Figure 6 – Key Cylinder..... 5

Drawing – Models E-1500L, E-1520L, E-300L and E-320L..... 8-10

Drawing – Models E-1500L, E-300L, E-600L, and E-620LDW..... 12

Drawing – Typical Installation for Drenching Showers..... 14

Drawing – Models E-4500L, E-600L, E-900L, E-10500L, and E-1200L..... 16-19

Drawing – Recirculation Switch Connection Diagram..... 20

Model Number and Material of Construction						
Model Number						Description
45 gpm	60 gpm	75 gpm	90 gpm	105 gpm	120 gpm	
E-4500L	E-600L	E-7500L	E-900L	E-10500L	E-1200L	Ductile Iron Shell, Copper Coils
E-4501L	E-601L	E-7501L	E-901L	E-10501L	E-1201L	Ductile Iron Shell, Admiralty Coils
E-4502L	E-602L	E-7502L	E-902L	E-10502L	E-1202L	Ductile Iron Shell, Cupro-Nickel Coils
E-4520L	E-620L	E-7520L	E-920L	E-10520L	E-1220L	Steel Shell, Copper Coils
E-4521L	E-621L	E-7521L	E-921L	E-10521L	E-1221L	Steel Shell, Admiralty Coils
E-4522L	E-622L	E-7522L	E-922L	E-10522L	E-1222L	Steel Shell, Cupro-Nickel Coils
E-4540L	E-640L	E-7540L	E-940L	E-10540L	E-1240L	Steel Shell, Copper Coils, ASME "U" Stamp
E-4541L	E-641L	E-7541L	E-941L	E-10541L	E-1241L	Steel Shell, Admiralty Coils, ASME "U" Stamp
E-4542L	E-642L	E-7542L	E-942L	E-10542L	E-1242L	Steel Shell, Cupro-Nickel Coils, ASME "U" Stamp
E-4550L	E-650L	E-7550L	E-950L	E-10550L	E-1250L	Steel Shell, Copper Coils, ASME "UM" Stamp
E-4551L	E-651L	E-7551L	E-951L	E-10551L	E-1251L	Steel Shell, Admiralty Coils, ASME "UM" Stamp
E-4552L	E-652L	E-7552L	E-952L	E-10552L	E-1252L	Steel Shell, Cupro-Nickel Coils, ASME "UM" Stamp

SECTION I

INSTALLATION

- HEATER MAY BE WALL OF FLOOR STAND MOUNTED — Allow recommended clearances over, under and around heater shown on Piping Layout Drawing for maintenance purposes; page 7-8.

WARNING: When connecting heater to other than copper pipe use dielectric unions, (isolators) to prevent possible galvanic action.

- CONNECTION OF STEAM TRAP DISCHARGE PIPING — Trap MUST discharge into an atmospheric or sub-atmospheric system. Condensate should be free flowing with no lift. If steam supply pressure is greater than 5 psig the MAXIMUM elevation of trap discharge line above Heater is 6 feet. If steam supply pressure can vary or if maximum efficiency is required, best results under all operating conditions will be obtained if trap discharges to atmospheric or sub-atmospheric line located below level of trap.
- A safety valve must be installed in inlet steam piping if steam pressure to Heater can exceed 75 psig for ductile iron exchangers, 150 psig for steel exchangers. See Piping Installation Drawing No. 90/2.4.1 for details.

An adequate trap system must be provided to insure that inlet steam piping to Heater is properly drained.

- A pressure gauge must be installed in the inlet steam piping close to Heater.
- A spring loaded relief valve is incorporated in the blending valve to relieve excess pressure that can be caused by thermal expansion of water during a shut-off or no load condition.
- Install a thermometer in hot water outlet piping close to Heater.
- OPERATING FEATURES — Normally a heat exchanger having a constant fixed steam supply pressure and a variable output flow demand allows water temperature to increase as flow demand decreased, and decrease as flow demand increases. This Heater has a unique adjustable gain feature incorporated in the Heater control system that automatically compensates in most part for the wide temperature variations normally encountered when an uncontrolled steam supply pressure is used. Compensation is accomplished by reportioning the blend ratio of hot and cold water on an automatic Feedforward basis. The blending valve incorporated a third window which is normally closed by a seal plate assembly. In the event that some dirt or foreign material enters the blending valve preventing its movement, the yielding spring will allow the diaphragm and stem to move upward, opening the third window. As seal plate uncovers third window, it allows cold water to flow into the blended mix, thus preventing water from becoming overheated.

STEAM AND WATER OPERATING PRESSURES FOR MODELS LOW PRESSURE CONSTANTEMP HEATERS

- STEAM PRESSURE — 2 to 15 psig.
- WATER PRESSURE AT COLD WATER INLET OF HEATER — Maximum water pressure MUST be 5 psig ABOVE maximum steam pressure used to operate heater.

SECTION II

START-UP PROCEDURE

1. Turn on cold water supply. With no water flow through heater, slowly open steam stop valve to heat exchanger making sure traps are functioning properly to prevent water hammer.
2. Loosen pipe plug in top of heat exchanger casing and vent all air from casing before retightening pipe plug.

NOTE: BEFORE making any water temperature or gain control adjustments, please refer to Capacity and Adjustment Table (Page 3) and Gain Control Curves Diagram (Page 4) so that maximum efficiency may be obtained from Heater by proper use of the information provided by these charts.

3. Loosen set screw in temperature adjustor (14) lock nut (13) and move lock nut away from cover plate (16) (See Fig. 1). Check Capacity and Adjustment Table and after determining Heater capacity shown under your operating conditions, adjust flow through Heater for approximately 50% of calculated capacity. Move temperature adjustor (14) to the right or left until the desired water temperature is achieved.
4. NOTE: There must be a water flow through Heater in order to adjust setpoint gain. Operate Heater from minimum to maximum flow and observe temperature at both of these extremes. Rotate gain control as shown on Gain Adjustment Curve Diagram until water temperature variations are reduced to a minimum. Move gain adjustor in small increments while adjusting, as total rotary movement of adjustor is only 30 degrees. (See Fig. 2)
5. After adjustments are completed, move lock nut (13) until it is against plate (16) and lock in place with lock nut set screw.
6. Heater is now adjusted and operating. No other adjustments should be necessary unless there is a change in your initial operating conditions. To SHUT DOWN HEATER close steam stop valve first, followed by water stop valve.

E-300L, E-600L, E-1500L, E-4500L CAPACITY AND ADJUSTMENT TABLE (Capacity in GPM) Numbers in brackets are approximate Gain Adjustor settings in degrees. * Maximum water temperature setting for E-1500L and E-300L is 150° ** Steam pressure is measured at the Heat Exchanger inlet.	INLET WATER TEMP °F	SET POINT °F	E-1500LM E-300L				E-4500L, E-600L			
			**STEAM PRESSURE PSIG							
			2	5	10	15	2	5	10	15
		120	27(25°)	20(24°)	30(23°)	30(22°)	54(15°)	60(14°)	60(13°)	60(12°)
		140	20(30°)	22(30°)	24(30°)	27(30°)	46(36°)	54(25°)	58(25°)	60(20°)
	40	150	17(30°)	19(30°)	21(30°)	23(30°)	40(30°)	49(30°)	53(27°)	54(25°)
		160	*	*	*	*	34(30°)	41(30°)	44(30°)	46(30°)
		180	*	*	*	*	21(30°)	23(30°)	25(30°)	28(30°)
		12	30(22°)	30(21°)	30(20°)	30(19°)	60(12°)	60(11°)	60(10°)	60(9°)
		140	23(25°)	25(24°)	27(23°)	30(22°)	57(15°)	59(14°)	60(13°)	60(12°)
	60	150	20(28°)	22(27°)	24(27°)	27(26°)	49(23°)	54(21°)	57(18°)	60(16°)
		160	*	*	*	*	42(30°)	49(28°)	51(25°)	56(20°)
		160	*	*	*	*	29(30°)	33(30°)	39(30°)	44(30°)

**TO DRAIN UNIT FOR PROLONGED SHUT-DOWN
(Where drainage is necessary)**

1. Turn off steam supply and water supply.
2. Open a vent line in high point of system piping.
3. Remove relief valve to drain water from control valve.
4. Open drain connections in steam and condensate lines.
5. Be sure all water is drained from hot water control valve and system if there is any danger of freezing.
6. When restarting system, tighten all connections and close all vents. Follow instructions shown in Section II - Start-up Procedure to put Heater back in operation.

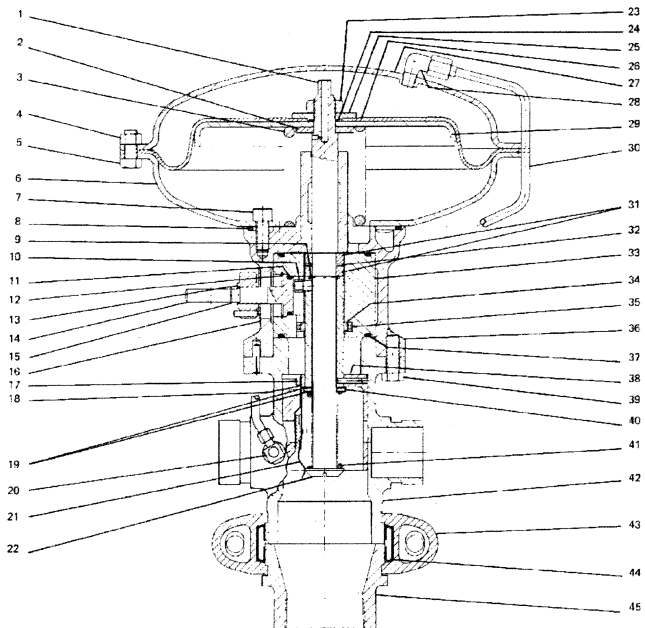

E-7500L, E-900L, E-10500L, E-1200L, CAPACITY AND ADJUSTABLE TABLE (Capacities in GPM) Numbers in brackets are approximate Gain Adjustor settings in degrees. **Steam Pressure is measured at the Heat Exchanger inlet.	INLET WATER TEMP. °F	SET POINT °F	E-7500L, E-900L				E-10500L, E-1200L			
			**STEAM PRESSURE PSIG							
			2	5	10	15	2	5	10	15
		105-110	87	90	90	90	116	120	120	120
		120	81(15°)	90(14°)	90(13°)	90(12°)	108(15°)	120(14°)	120(13°)	120(12°)
		140	69(30°)	81(28°)	87(25°)	90(20°)	92(30°)	108(28°)	116(25°)	120(20°)
	40	150	60(30°)	73(30°)	79(27°)	81(25°)	80(30°)	98(30°)	106(27°)	108(25°)
		160	51(30°)	61(30°)	66(30°)	69(30°)	68(30°)	82(30°)	88(30°)	92(30°)
		180	31(30°)	34(30°)	37(30°)	42(30°)	42(30°)	46(30°)	50(30°)	56(30°)
		105-110	90	90	90	90	120	120	120	120
		120	90(12°)	90(11°)	90(10°)	90(9°)	120(12°)	120(11°)	120(10°)	120(9°)
		140	85(15°)	88(14°)	90(13°)	90(12°)	114(15°)	118(14°)	120(13°)	120(12°)
	60	150	73(23°)	81(21°)	85(18°)	90(16°)	98(23°)	108(21°)	114(14°)	120(16°)
		160	63(30°)	73(28°)	76(25°)	84(20°)	84(30°)	98(28°)	102(25°)	112(20°)
		180	43(30°)	49(30°)	58(30°)	66(30°)	58(30°)	66(30°)	78(30°)	88(30°)

SECTION III

MAINTENANCE OF SYSTEM COMPONENTS Hot Water Control Valves Dismantling

1. Close all steam and water inlet and outlet stop valves. Disconnect tubing from valve body and upper diaphragm case.
2. Disconnect Victaulic coupling (43) and remove gasket (44). Remove reducing coupling (45) and remove tubing (30).
3. Loosen and remove casing bolts (5) and nuts (4). Lift off upper diaphragm case (27).
4. Remove retaining ring (15) from temperature adjustor (14) followed by lock nut (13) and cover plate (16).
5. Take out retaining ring (12) from adjusting sleeve (33) and take out temperature adjustor (14) and key cylinder (10).
6. Hold upper stem (1) fast by placing an open end wrench on the upper stem flats and remove the jam nut (23) with another wrench.
7. Take out the shouldered washer (25), O-ring (24), diaphragm (26), diaphragm plate (29), control valve spring (3), and the spring guide washer (2) from the lower diaphragm case (6).

CAUTION: Do not allow valve plug assembly to fall from lower end of the valve body.

8. Take valve plug assembly from lower opening of valve body (42).

9. Remove socket head cap screws (7) and take off lower diaphragm case (6). Take out O-ring (8) from top of yoke (36).
10. Disconnect Victaulic couplings from valve body (42) and remove gaskets.
11. Take out cap screws (39) and remove valve body (42).
12. Push temperature adjusting sleeve (33) out of yoke (36).
13. Valve plug assembly should not be disassembled unless parts replacement is necessary due to wear or damage. For disassembly, see instructions covering assembly of valve plug and reverse instruction procedure.
14. All parts should be cleaned with an approved solvent. Wipe off with a clean cloth. Do Not Use Abrasives of any kind. Care should be taken in handling parts so as not to damage critical surfaces. Replace any badly worn or damaged surfaces.

NOTE: If a complete dismantling of control valve is necessary, it is recommended that valve be removed from Heater and work performed on a work bench.

ACTUATOR ASSEMBLY

IMPORTANT: Lubricate all O-rings with Silicon Grease.

1. Place O-ring (8) in the top of yoke (36). Position and attach lower diaphragm case (6) to the yoke. (See Fig. 3) Fasten case to the yoke with cap screws 97 sequentially from each other until tight.
2. Install O-ring (37) in temperature adjusting sleeve (33) grooves. Insert guide energizer (35) (rubber) and valve

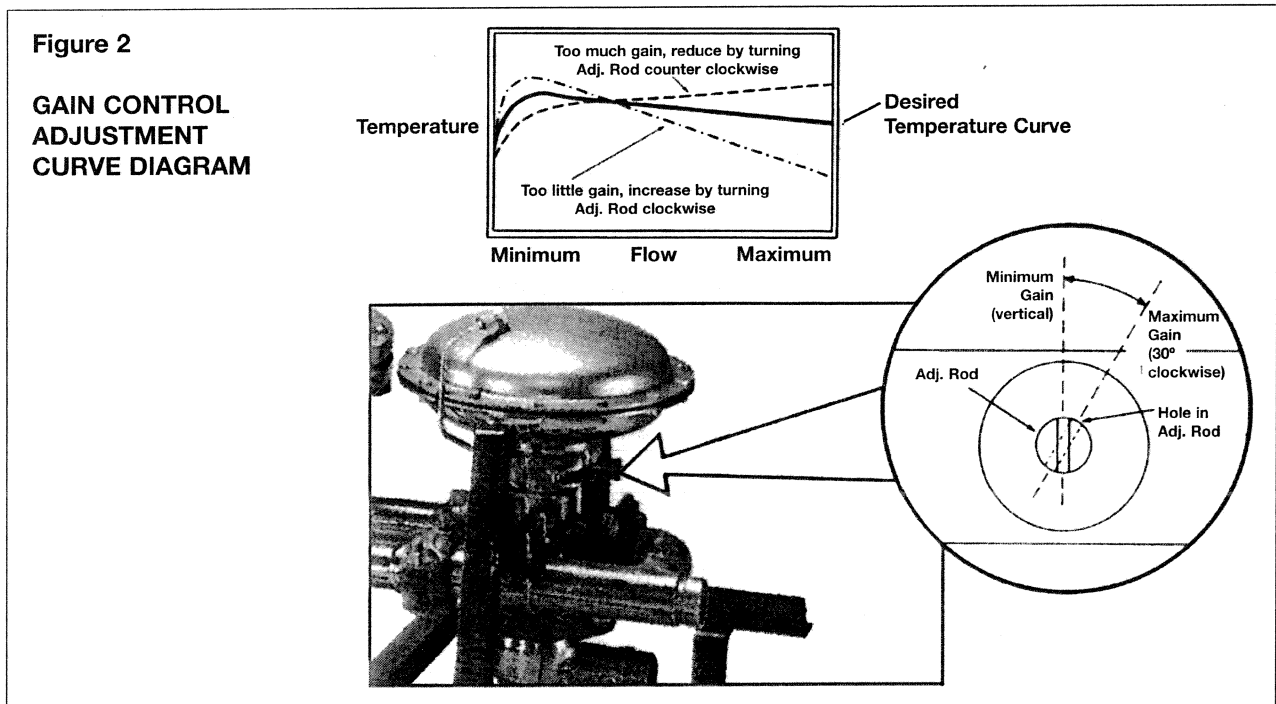

plug guide (34) (Teflon) into groove in bore of adjusting sleeve (33). Chamfer on guide to face out, ends should butt against the two Groove-pins. (See Fig. 4 and Fig. 6)

3. Insert temperature adjusting sleeve assembly (33) into yoke (36) with Teflon guide (34) facing out and hole in side of sleeve lining up with yoke window.

Figure 3

TOP VIEW SHOWING POSITION OF NOTCHES TO VALVE BODY, ALSO TUBING AND FITTING TO COLD WATER INLET

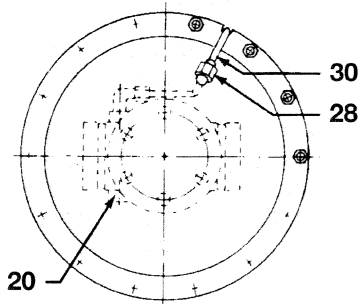

VALVE PLUG ASSEMBLY

4. Fasten seal plate assembly (21) to valve plug (38) with screws (17) and lock washers (18).
5. Place a stem collar washer (31), Teflon thrust washer (32), and a second stem collar washer (31) in this order over upper stem (1) making sure parts shoulder on step of upper stem. Insert Spirolox retaining ring (9) into upper stem (1) groove.

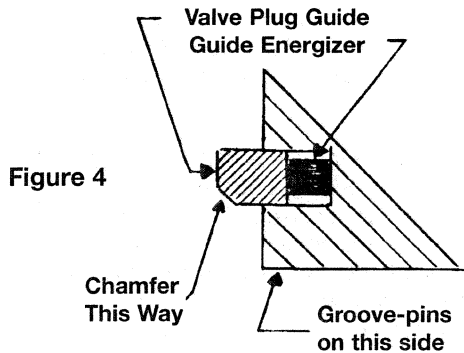

6. Insert upper stem (1) through small hole in valve plug (38) so that stem collar (31) will rest on the smaller end of valve plug.
7. Place bearing assembly, which consists of washing (19), thrust washer (40) and washer (19) over upper stem (1) into large bore of valve plug (38) so that it rests on bottom of bore, and follow with spring seat washer (19) and yield spring (41). Hold upper stem (1) at extreme upper end of stem with a wrench.
8. Tighten screw (22) making sure that screw shoulders on lower section of upper stem. Apply a light coating of Silicon Grease to the surface of the valve plug.

CONTROL VALVE ASSEMBLY

9. Install pressure relief valve (20) in boss on side of body. Make sure correct valve body (42) is used. Body is identified by a drilled hole on side of flange on center line above hot water inlet for E-300L body. E-600L has no identification hole drilled in flange.
10. Assemble valve body (42) to yoke (36) with cold water inlet facing in the same direction as window in yoke. Secure with cap screws (39).
11. Install O-ring (11) in groove of temperature adjustor (14), and, temporarily for alignment purposes, insert adjustor through yoke window. Keyway must be vertical and notch on outer diameter of adjustor, and line up with pin in temperature adjusting sleeve (33) (See Fig. 5) DO NOT INSTALL RETAINING RING (12).

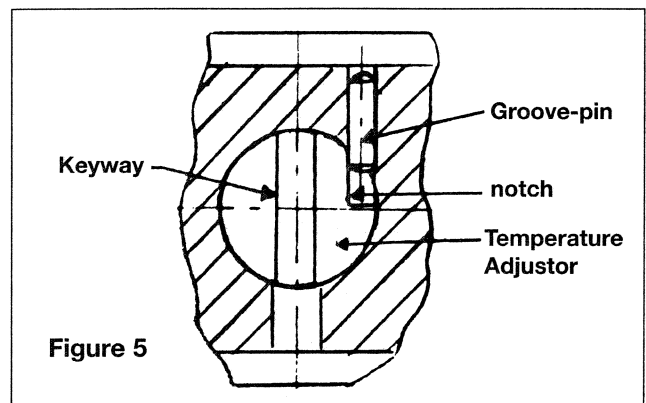

12. With valve plug key and temperature adjustor (14) lined up on approximately the same center line, insert valve plug assembly into valve body (42) bore. Plug assembly will move freely into body bore until stem collar hits Teflon guide in temperature adjusting sleeve (33). Push plug stem up through guide until plug hits stop in valve body. If plug does not bottom against valve stop, turn temperature adjustor (14) back and forth while pushing plug upwards until key enters into keyway in temperature adjustor (14). With plug against stop in body, the lower end of plug will be approximately 2-3/16 inches inside the lower face of body.

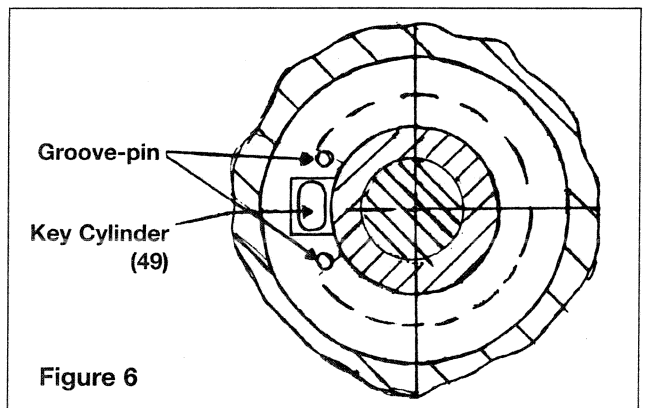

IMPORTANT: Plug assembly must be held in place during step 13.

13. Holding valve plug assembly in place, install the control valve spring (3). Make sure spring seats properly on yoke (36) spring seat area. Place spring guide washer (2) over upper stem and seat. Install diaphragm plate (29), diaphragm (26), O-ring (24), shouldered washer (25), and jam nut (23) over upper stem. Tighten jam nut after positioning diaphragm holes over lower diaphragm case (6) holes.
14. Install upper case (27) and position over diaphragm holes. Make sure diaphragm lays flat on flange and is not pinched or twisted. Fasten bolts (5) and nuts (4) sequentially across from each other until tight.

MAINTENANCE OF SYSTEM COMPONENTS HEAT EXCHANGER

Check tightness of all casing bolts and nuts after unit has been in operation for a few hours and again in twenty-four hours.

DISASSEMBLY

1. Disconnect water piping.
2. Remove all nuts around casing.
3. Remove casing from base plate.
4. Remove manifold nuts and lock rings. Coil manifold and manifold gaskets.

ASSEMBLY

Clean all parts and replace any damaged parts. Use new gaskets.

5. Install manifold gaskets between manifold collar and base plate. Insert coil manifolds into base plate.
6. Place lock rings over manifold ends with locks fitted into slots. Install manifold nuts and tighten securely. (A light coating of thread lubricant should be used on manifold threads before assembly of nuts.)
7. Place casing gasket on base plate and follow with casing. Make sure recesses inside casing line up with top of manifolds.
8. Install nuts and bolts and tighten evenly to assure a tight leakproof seal.
9. Reinstall water piping.
10. Vent steam side of heater as described under Section II - Start-up Procedure.

SECTION IV - TROUBLE SHOOTING GUIDE FOR LESLIE CONSTANTEMP HEATERS - TYPES E-1500L, E-300L, E-4500L, E-600L

IMPORTANT! Study installation drawings and CAREFULLY read the details concerning installation of your Heater and Trapping System. Following these recommendations will insure that you obtain the maximum efficiency from your CONSTANTEMP HEATER.

TROUBLE SHOOTING GUIDE Recirculating Systems

1. PROBLEM: EXCESSIVE RISE IN WATER TEMPERATURE OCCURRING DURING OR AFTER PROLONGED PERIODS WHEN NO WATER IS BEING USED FROM HEATER AND A RECIRCULATING SYSTEM IS PROVIDED.
 1. Too much water being recirculated through heater. Reduce water flow through heater by throttling recirculation stop valve to allow enough time for water in piping system to cool and assume new temperature setting. If piping system is extensive and contains a large volume of water, readjustment of temperature can be speeded up by closing steam supply stop valve to heat exchanger and by then opening faucets etc.; preferably at end of loop until water temperature drops a few degrees below heaters' adjusted water temperature. Close off recirculation stop valve and open steam stop valve to heater. With recirculating pump in operation, open recirculation stop valve in small increments while allowing adequate time for water to be recirculated throughout piping before proceeding to next increment of adjustment. Continue until desired recirculation water temperature is achieved.
 2. IF A THREE-WAY THERMOSTATIC VALVE IS USED, the port connected to the heaters' cold water supply MUST CLOSE to prevent excessive flow of water back to heater. An excessive flow will cause water temperature in piping to rise above adjusted temperature setting of heater. If port does not close, check for dirt or obstruction between seating surfaces, or for damaged element or seals.
 3. CHECKING FOR FAULTY ELEMENT, immerse unit in an agitated bath of hot water. With a rise in water temperature of from 10 to 12°F above rated operating range of element, the port connected to heaters' cold water supply pipe should be replaced.
4. NOTE: Operating range of Thermostatic Valve should normally be from 10 to 15°F lower than that of Heaters' adjusted water operating temperature. If heater is adjusted for 140°F hot water and a 110°F 3-way valve is used, the recirculated water will assume a temperature of 110°F during prolonged periods when

no water is being used from heater. If a 180°F range unit is used under the same conditions as above, the recirculated water temperature will rise to 180°F.

2. **PROBLEM: EXCESSIVE DROP IN WATER TEMPERATURE OCCURRING DURING OR AFTER PROLONGED PERIODS WHEN NO WATER IS BEING USED FROM HEATER AND RECIRCULATING SYSTEM IS PROVIDED.**

1. Check for correct inlet steam pressure to heat exchanger.
2. No water being recirculated back to heater. Check recirculating system for proper operation of pump, recirculation valves and controls.

**TROUBLE SHOOTING GUIDE
Heat Exchanger and Blending Valve**

3. **PROBLEM: DROP IN CONTROLLED WATER TEMPERATURE OCCURRING BEFORE RATED CAPACITY (GPM) OF YOUR HEATER IS OBTAINED.**

1. Check for correct inlet water operating pressure and steam pressure to heater before and during any operational test. **LOW PRESSURE Heaters** - water pressure **MUST** be at least 5 psig **ABOVE** maximum steam pressure used to operate Heater.

The **MAXIMUM** water pressure for all Heaters is 150 psig.

NOTE: Seal plate (Part 45) must be tight seating to prevent cold water from leaking into blended water. This can cause an uncontrolled drop in blended water adjusted temperature.

2. Check to make sure all steam strainers are clean and that all traps are functioning efficiently. A flooded or partly flooded heat exchanger will cause little or no heat transfer. Excessive back pressure in trap discharge piping system, or partly clogged piping can restrict flow of condensate from Heater and cause flooding. Dirty or partly plugged strainer screens can also cause this problem.

The above system must be operating efficiently before any check for fouled coils can be made.

3. To check for fouled coils, remove pipe plugs from blending valve base and cover, and install a gauge in each connection. Temperature of water from heat exchanger outlet piping should be approximately 200 to 215°F when heater is being operated within its rated capacity. (Temperature may be checked by using a contact Pyrometer held against a smooth filed section of exchanger outlet piping.)

Steam pressures of from 2 to 15 psig may be checked by using the **CAPACITY AND ADJUSTMENT TABLE** found in your Heater Manual to determine GPM and water temperature per your operating conditions.

TEST PROCEDURE: With traps functioning efficiently, and with flow adjusted for 60% of heater rated capacity (approx. 5 psig differential across blending valve diaphragm), the heat exchanger outlet water temperature drops below 200°F and continues to drop as flow is increased to heaters' rated capacity in GPM, it indicates that coils are fouled and should be cleaned or replaced. A coil cleaning Adaptor Kit is available through your Leslie Representative, along with instructions for its use. If quality of water being used for Heater is poor, coils may foul rapidly indicating that corrective water treatment may be necessary.

4. **PROBLEM: INSUFFICIENT STEAM TO HEAT EXCHANGER.**

1. See Paragraphs 1 and 2 above of trouble shooting guide.
2. Check steam reducing valve operation, if one is used with Heater.

5. **PROBLEM: EXCESSIVE STEAM PRESSURE TO HEAT EXCHANGER.**

1. Check steam reducing valve if one is used or steam source supplying heater.

6. **PROBLEM: EXCESSIVE RISE IN WATER TEMPERATURE ABOVE HEATERS' SETPOINT OCCURRING AT LOW FLOWS.**

1. The above problem may occur if Heater Controlled Temperature is overset due to:

- a. fouled coils
- b. drop in inlet water supply pressure
- c. adjustment of controlled water temperature while exceeding Heaters' rated capacity in GPM.

See Paragraphs 1 and 2 of the second problem for further information.

7. **PROBLEM: EXCESSIVE DROP IN WATER TEMPERATURE BELOW HEATERS' ADJUSTED SETPOINT OCCURRING DURING LOW FLOW.**

1. See Paragraph 1 of Problem 2 above.
2. Inefficient trap operation or increase in trap discharge drain piping backpressure. See Paragraph 2 of Problem 3.
3. Too little gain. Readjust gain setting as shown in Paragraph 2 of Problem 3.

NOTE: A 3°F change in inlet water temperature to Heater will produce a change in the Heaters' adjusted water temperature of 1°F.

CONSTANTEMP HEATER, MODEL E-1500L, E-1520L, E-300L AND E-320L

MODEL		PIPE SIZE				E	F	H PSI	L
		A	B	C	K				
E-1500L	in	1-1/2	2	1-1/4	3	4-5/8	5-1/4	30	17.5
E-300L	mm	38.1	50.8	31.7	76.2	117.5	133.3	HQVAC	444.5
E-320L									
E-4500L	in	2	2	2	4	5-5/8	5-1/4	TO	17.5
E-600L	mm	50.8	50.8	50.8	101.6	142.9	133.3	30 PSI	444.5
E-620L									

MODEL		P	Q	R	S	T	U	X
E-1500L	in	12-1/16	6-11/16	5-23/32	1-1/4	10-1/4	15-13/16	1-3/16
E-300L	mm	306.4	169.9	145.3	31.7	260.3	401.6	30.2
E-1520L	in	11-1/4	5-7/8	5-3/4	11-11/16	10-1/16	15-13/16	1-3/16
E-320L	mm	285.7	149.2	146.0	296.5	255.6	401.6	30.2
E-4500L	in	12-1/2	5-5/8	5-3/4	3-7/8	7-7/8	17-13/16	1
E-4520L								
E-600L	mm	317.5	142.9	146.0	98.4	200	452.4	25.4
E-620L								

J - BOTTOM MTG. FRAME TO BOTTOM SIDE STEAM INLET ON EXCHANGER.
M - BOTTOM MTG. FRAME TO BOTTOM SIDE CONDENSATE OUTLET ON EXCHANGER.
N - BLEND VALVE BODY TO BOTTOM HOT WATER OUTLET

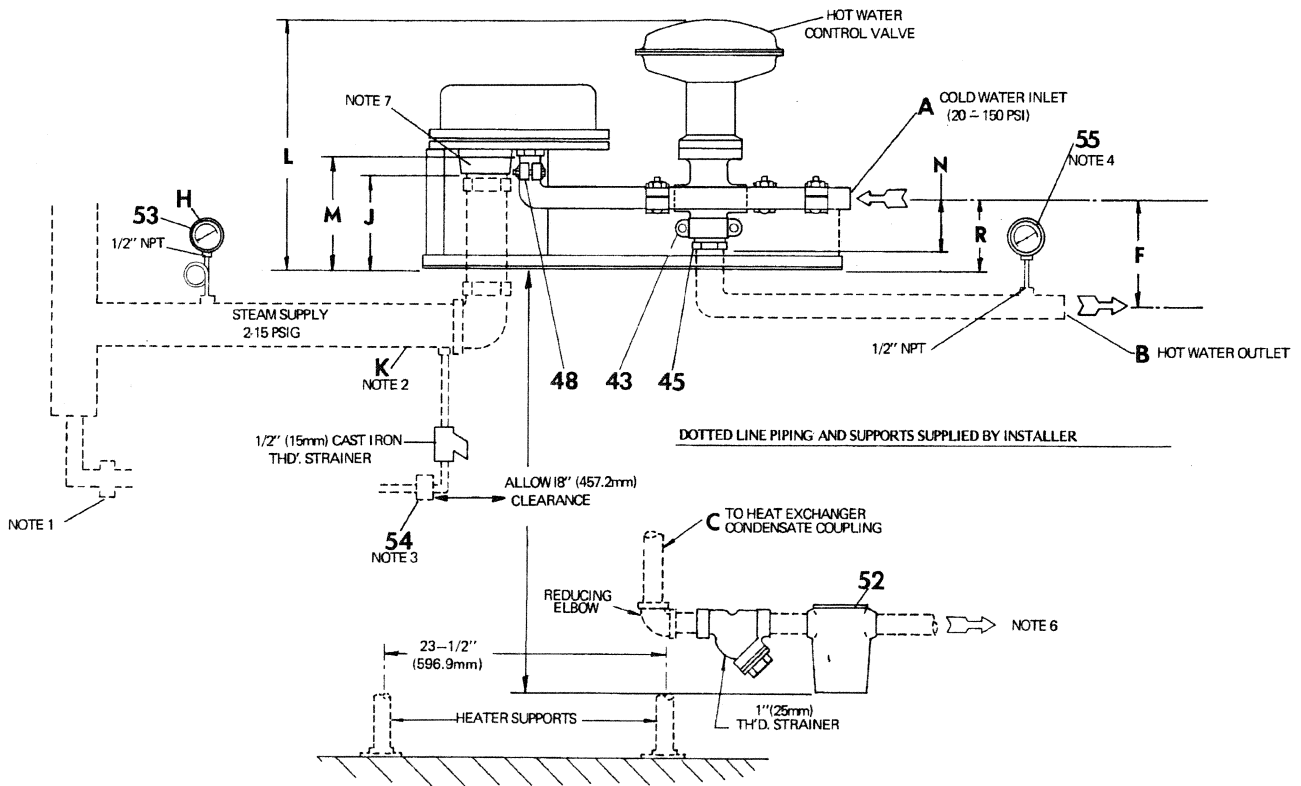

MODEL		J	M	N
E-1500L	in	8-3/4	10-3/8	5-3/16
E-300L	mm	222.2	263.5	131.8
E-1520L	in	9-9/32	10-11/16	5-3/16
E-320L	mm	235.7	271.5	131.8
E-4500L				
E-4520L				
E-600L				
E-620L				

CONSTANTEMP HEATER, MODEL E-1500L, E-1520L, E-300L AND E-320L

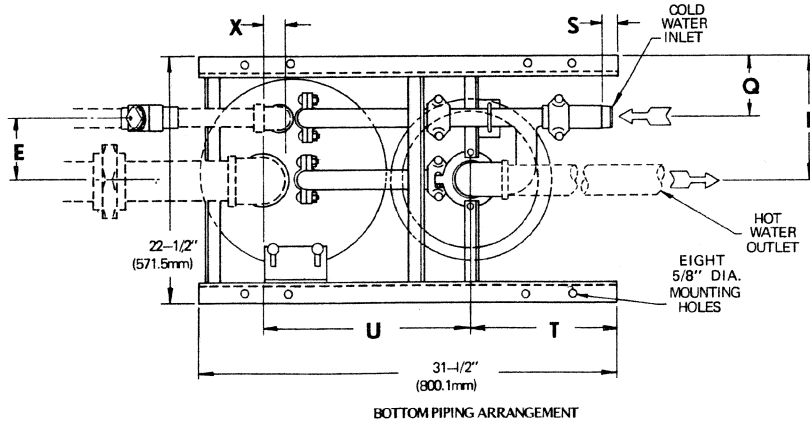
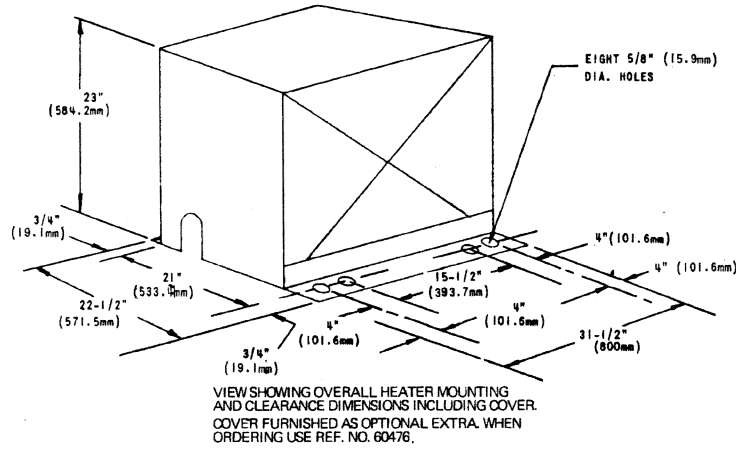

INSTALLATION CHECK LIST
NOTE 1: PROVIDE ADEQUATE DRIP LEG AND TRAP TO KEEP STEAM SUPPLY LINE FREE OF CONDENSATE.
NOTE 2: INSTALL SAFETY VALVE AT THIS CONNECTION WHEN STEAM SUPPLY PRESSURE MAY EXCEED 75 PSIG FOR DUCTILE IRON EXCHANGERS AND 150 PSIG FOR CAST STEEL EXCHANGERS.
NOTE 3: INSTALL SMALL TRAP AND STRAINER TO DRAIN CONDENSATION DURING NO LOAD OR STANDBY CONDITION.
NOTE 4: INSTALL THERMOMETER SUPPLIED IN OUTLET HOT WATER LINE.
NOTE 5: INSTALL STOP VALVES ON STEAM CONDENSATE AND WATER INLET AND OUTLET LINES.
NOTE 6: SEE TABLE FOR MAX. ELEVATION OF CONDENSATE DISCHARGE.

APPROXIMATE WEIGHT	E-1500L	260	117.8
EXCLUDING STEAM TRAP	E-300L	260	117.8
APPROXIMATE WEIGHT STEAM TRAP		27 lb	12.2 kg
HEATER MAY BE SUPPORTED BY FLOOR, SUSPENSION OR WALL BRACKET TYPE, FLOOR TYPE SHOWN			

MAXIMUM ELEVATION TABLE		
INLET STEAM PRESSURE (PSIG)	MAX. ELEV. COND. DISCHARGE	
	2-4	0 ft.
5-6	2 ft.	61. cm
7-8	4 ft.	121.9 cm
9-10	6 ft.	182.9 cm
10-12	8 ft.	243.8 cm
12-15	10 ft.	304.0 cm

CONSTANTEMP HEATER, MODEL E-1500L, E-1520L, E-300L AND E-320L

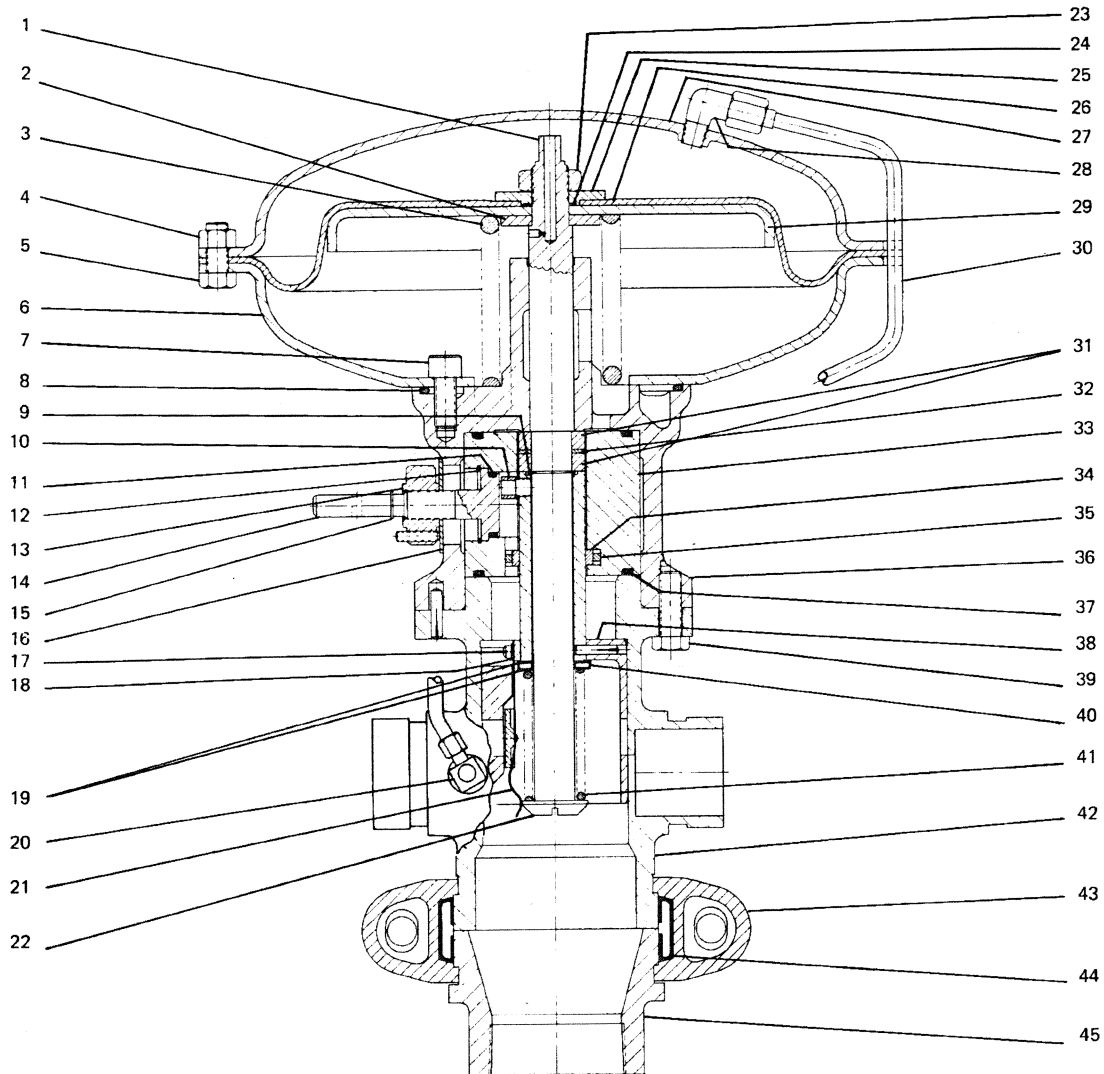

MODEL NUMBER AND MATERIALS OF CONSTRUCTION:

MODEL NUMBER		DESCRIPTION
15GPM	30GPM	
E-1500L	E-300L	Ductile Iron Shell, Copper Coils
E-1501L	E-301L	Ductile Iron Shell, Admiralty Coils
E-1502L	E-302L	Ductile Iron Shell, Cupro-Nickel Coils
E-1520L	E-320L	Steel Shell, Copper Coils
E-1521L	E-321L	Steel Shell, Admiralty Coils
E-1522L	E-322L	Steel Shell, Cupro-Nickel Coils
E-1540L	E-340L	Steel Shell, Copper Coils, ASME "U" Stamp
E-1541L	E-341L	Steel Shell, Admiralty Coils, ASME "U" Stamp
E-1542L	E-342L	Steel Shell, Cupro-Nickel Coils, ASME "U" Stamp
E-1550L	E-350L	Steel Shell, Copper Coils, ASME "UM" Stamp
E-1551L	E-351L	Steel Shell, Admiralty Coils, ASME "UM" Stamp
E-1552L	E-352L	Steel Shell, Cupro-Nickel Coils, ASME "UM" Stamp

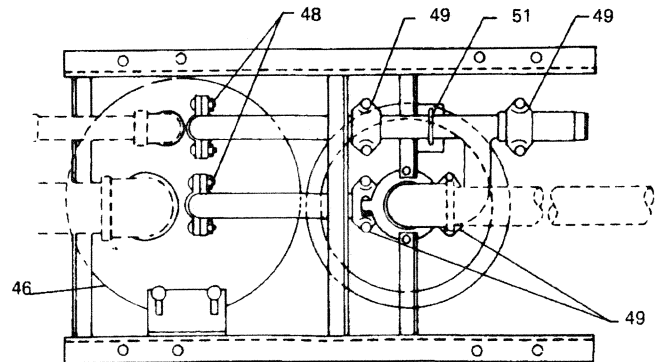

REFERENCE NUMBERS FOR PARTS NOT SHOWN ON DRAWING:

PART NAME	E-1500L	E-300L	E-1520L	E-320L
*Copper Coil For Part No. 46**	011854096	011854085	011964202	011854086
*Manifold Gasket For Part No. 46	72584	72584	72584	72584
*Casing Gasket For Part No. 46	56685-67	56685-67	57961-67	57961-67
*Coupling Gasket For Part No.47	56236	56236	56236	56236
*Coupling Gasket For Part No. 48	56548	56548	56548	56548
Coil Lock Ring (Note 2)	61394	61394	61394	61394
Coil Lock Nut (Note 2)	59409	59409	59409	59409

CONSTANTEMP HEATER, MODEL E-1500L, E-1520L, E-300L AND E-320L

PART NO.	PART NAME	MATERIAL	E-1500L QTY. PER UNIT	REF. NO.	E-300L QTY. PER UNIT	REF. NO.
1.	Upper Stem	Stainless Steel	1	66688	1	66688
2.	Spring Guide Washer	Stainless Steel	1	64632	1	64632
3.	Controlling Valve Spring	Stainless Steel	1	66696	1	66696
4.	Nut	Steel	14	26585	14	26585
5.	Bolt	Steel	14	37797	14	37797
6.	Diaphragm Case-Lower	Stainless Steel	1	64443	1	64443
7.	Socket H.D. Cap Screw	Steel	6	39655	6	39655
8. *	O-Ring	Synthetic Rubber	1	64769-94	1	64769-94
9. *	Spirolox Ring	Stainless Steel	1	59025	1	59025
10.	Key Cylinder	Stainless Steel	1	58998	1	58998
11. *	O-Ring	Synthetic Rubber	1	59052-94	1	59052-94
12. *	Retaining Ring	Stainless Steel	1	59023	1	59023
13.	Lock Nut-Complete	Brass	1	59001	1	59001
14. *	Gain Adjustor	Stainless Steel	1	58995	1	58995
15. *	Retaining Ring	Copper	1	59024	1	59024
16.	Cover Plate	Brass	1	59009	1	59009
17.	Screw	Stainless Steel	2	70929	2	70929
18.	Lockwasher	Stainless Steel	2	70930	2	70930
19.	Spring Seat Washer	Stainless Steel	2	59013	2	59013
20.	Relief Valve	Brass	1	59121	1	59121
21.	Seal Plate Assembly	Stainless Steel	1	59031	1	59031
22.	Screw	Bronze	1	59486	1	59486
23.	Jam Nut	Steel	1	50547	1	50547
24. *	O-Ring	Synthetic Rubber	1	49746-94	1	49746-94
25.	Shouldered Washer	Stainless Steel	1	64645	1	64645
26. *	Diaphragm	Synthetic Rubber	1	37809-94	1	37809-94
27.	Diaphragm Case-Upper	Stainless Steel	1	64442	1	64442
28.	Male Elbow-Flared	Brass	1	64829	1	64829
29.	Diaphragm Plate	Stainless Steel	1	64641	1	64641
30.	Formed Tubing	Copper	1	66690	1	66690
31.	Stem Collar Washer, Upper	Stainless Steel	1	59014	1	59014
32.	Thrust Washer	Graphite Filled Teflon or Stainless Steel	1	59015	1	59015
33. *	Temp. Adjusting Sleeve Compl.	Stainless Steel	1	58989	1	58989
34.	Guide	Graphite Filled Teflon	1	59107	1	59107
35. *	Guide Energizer	Synthetic Rubber	1	59166	1	59166
36.	Yoke	Cast Bronze	1	66686	1	66686
37.	O-Ring	Synthetic Rubber	2	59029-94	2	59029-94
38. *	Valve Plug Complete Note 3	Monel	1	73463	1	73463
39.	Cap Screw	Steel	(Note 1)	(Note 1)	(Note 1)	(Note 1)
40.	Needle Bearing	Nylon & Stainless Steel	1	68484	1	68484
41. *	Yielding Spring	Stainless Steel	1	59019	1	59019
42.	Body	Cast Bronze	1	58986	1	58986
43.	Coupling	Malleable Iron	1-3"	55569	1-3"	55569
44. *	Gasket	Commercial	1	56237	1	56237
45.	Reducing Coupler	Cast Bronze	1	55483	1	55483
46.	Heat Exchanger, E1500L/E300L	Ductile Iron/Copper Coil	1	71702	1	68609
46.	Heat Exchanger, E1520L/E320L	Steel/Copper Coil	1	717022022	1	686092022
47.	Coupling	Malleable Iron	2-1-1/4"	55568	2-1-1/4"	55568
48.	Coupling	Malleable Iron	4-1-1/2"	56547	4-1-1/2"	56547
49.	Mounting Frame	Carbon Steel	1	67761	1	67761
50.	U-Bolt With Nuts	Steel	1	58654	1	58654
51.	1" F + T Trap	Cast Iron	1	72308	1	72308
52.	Pressure Gauge	Steel Case	1	63092	1	63092
53.	1/2" Steam Trap	Cast Iron	1	70653	1	70653
54.	Thermometer	Stainless Steel	1	60184	1	60184
55.	1" Strainer	Cast Iron	1	F000220053W	1	F000220053W
56.	1/2" Strainer	Cast Iron	1	F000220051W	1	F000220051W
57.	Nipple	Brass	1	56639	1	56639
58.	Inlet Manifold	Cast Bronze	1	58172	1	58172
59.	Exchanger Manifold	Cast Bronze	2	64905	2	64905
60.	Fitting (Male Elbow)	Brass	1	64770	1	64770
61.	Pigtail Siphon	Cast Iron	1	56745	1	56745
62.	Stem Thrust Washer, Lower	Graphite Filled teflon or Stainless Steel	1	59014	1	59014

NOTE 1: Requires four (4) R/N 45840 and two (2) R/N 59478.

NOTE 2: Furnished with Heater Coil but may be ordered separately.

NOTE 3: Includes seal plate (#21), screws (#17) and lock washers (#15)

* Recommended spare parts.

* These parts should be on hand, plus recommended spare parts, when overhauling equipment.

STEAM WATER HEATERS, MODELS E-1500L, E-300L, E-4500L AND E-600L

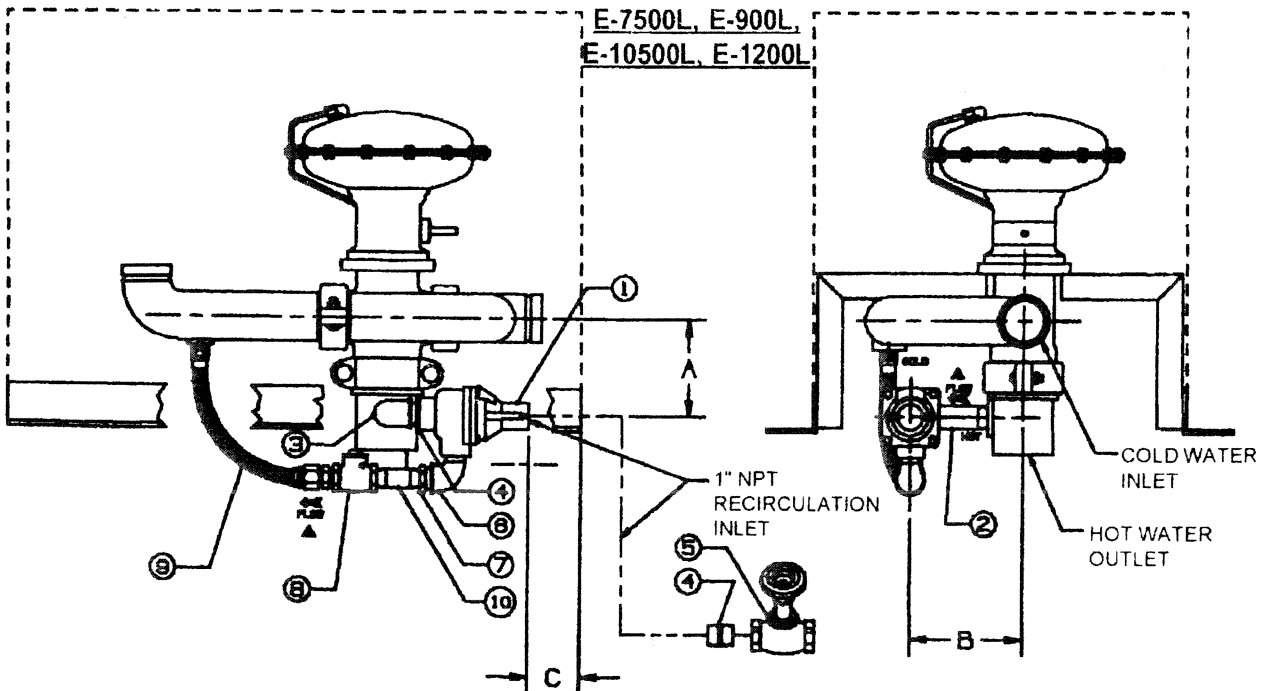
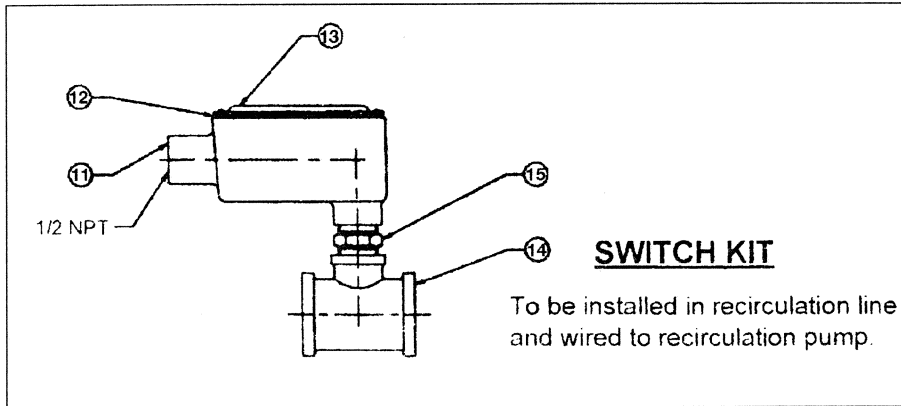
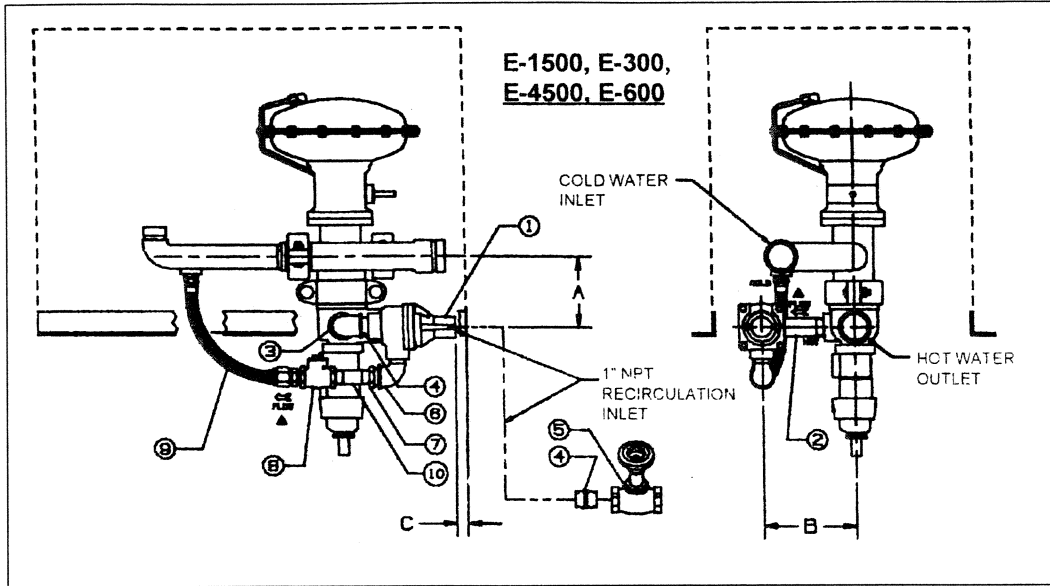

STEAM WATER HEATERS, MODELS E-1500L, E-300L, E-4500L AND E-600L

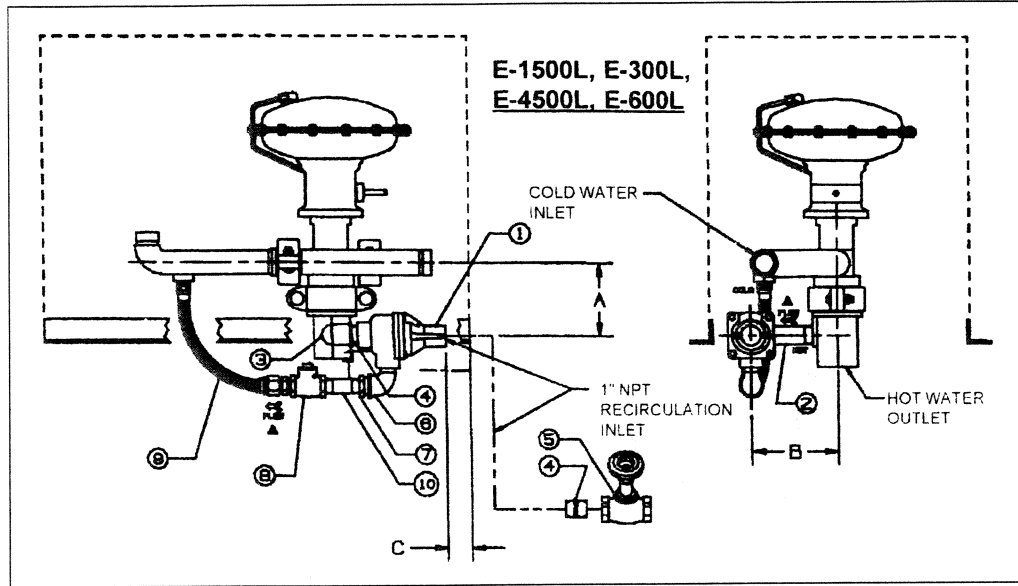

TABLE 1

FOR ALL HEATERS			
ITEM	QTY	REF NO	DESCRIPTION
1	1	SEE TABLE 2	3-WAY THERMOSTATIC VALVE
2	1	A74257	1" NPT x 3-1/2" NIPPLE
3	1	A60958	1" NPT 90° ELBOW, 125#
4	2	A60956	1" NPT x 1-1/2" NIPPLE
5	1	A70827	1" NPT GLOBE VALVE
6	1	A70823	1" NPT 90° STREET ELBOW
7	1	A70822	1" MALE NPT TO 3/4" NPT REDUCER
8	1	A70826	3/4" NPT CHECK VALVE
9	1	A70828	3/4" STAINLESS STEEL BRAIDED HOSE
10	1	A74256	3/4" NPT x 3" NIPPLE
11	1	A72763	CONDUIT BODY
12	1	A72765	CONDUIT BODY GASKET
13	1	A72764	CONDUIT BODY COVER
14	1	NB57113164	BRASS TEE 1 x 1 x 1/2"
15	1	SEE TABLE 2	THERMAL SWITCH

TABLE 2

FOR SPECIFIC TEMP RANGES		
KIT RATING	THERMO-VALVE REF. NO	THERMAL SWITCH REF. NO
95°F	A59809	A74274
110°F	A58935	A74267
120°F	A59295	A74270
130°F	A59259	A74269
140°F	A59593	A74273
150°F	A59518	A74271
160°F	A59543	A74272
170°F	A69881	A74275
180°F	A59201	A74268

TABLE 3

DIMENSIONS (± 0.1")			
HEATER STYLE	A	B	C
E-1500	5.3	6.9	0.8
E-300	5.3	6.9	0.8
E-4500	5.3	6.9	0.8
E-600	5.3	6.9	0.8
E-1500L	5.7	6.7	3.1
E-300L	5.7	6.7	3.1
E-4500L	5.7	6.7	3.1
E-600L	5.7	6.7	3.1
E-7500L	5.4	6.4	1.9
E-900L	5.4	6.4	1.9
E-10500L	5.4	6.4	1.9
E-1200L	5.4	6.4	1.9

NOTES:

- PARTS INDICATED ARE SUPPLIED TO CUSTOMER BAGGED, AND ARE TO BE PLACED IN LINE, AS SHOWN, WHEN HEATER IS INSTALLED.
- THERMAL SWITCHES ARE SET AT 10°F OVER NOMINAL THERMOSTATIC VALVE SETTING (KIT RATING).

The normal recirculation loop will require a one-inch thermostatic capsule. The setting of this capsule should be at least 10° F lower than the intended setpoint of the heater. The recirculating pump need only handle about 10% of the heater capacity with enough head to move the water around the recirculation loop.

START-UP OF THE STANDARD RECIRCULATION SYSTEM

- Open balancing valve fully.
- Start recirculating pump.

NOTE: Balancing valve is normally full open. Valve is throttle only when recirculation pump is over sized for the heater (10%).

Steam Water Heater, Model E-600L

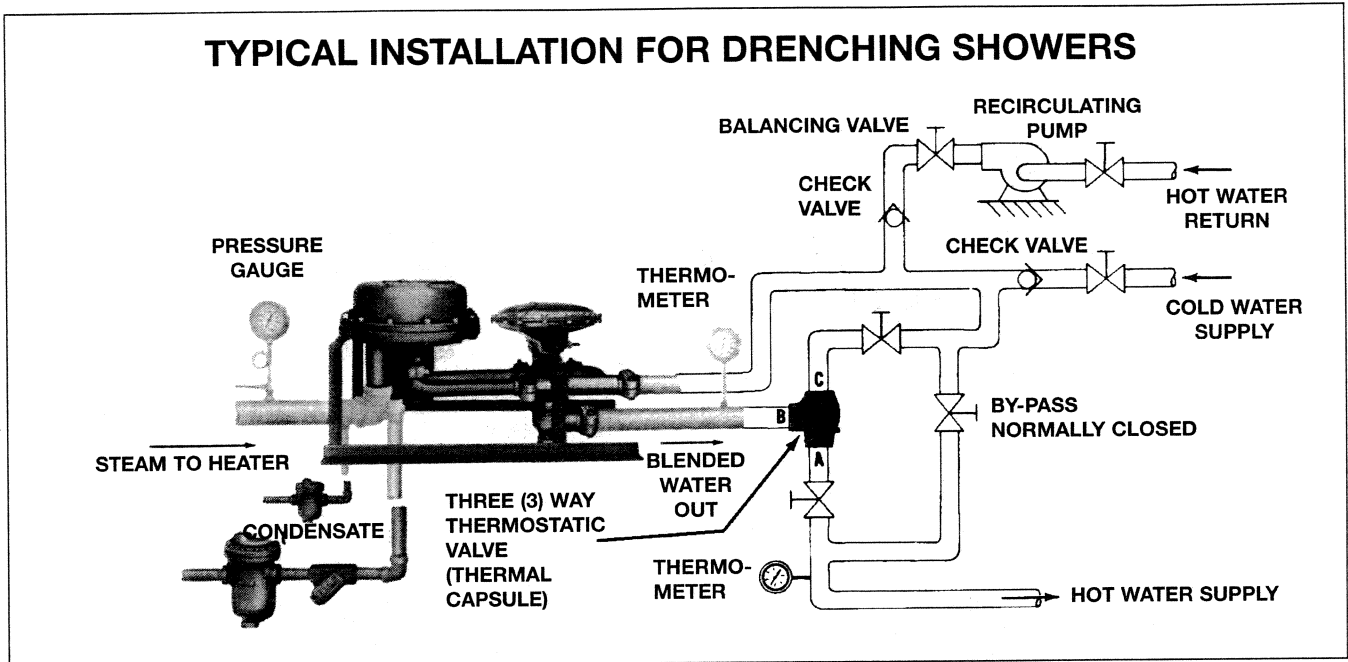

MISCELLANEOUS DATA

RELIEF VALVE SIZING

A relief valve is required when the shell pressure can exceed 75 psig (for ductile iron exchangers). A relief valve is required for steel exchangers if pressure exceeds 150 psig.

The selection and sizing of the relief valve should be done on the following basis:

NOTES:

CONSTANTEMP HEATER, Models E-4500L, E-600L, E-900L, E-10500L, and E-1200L

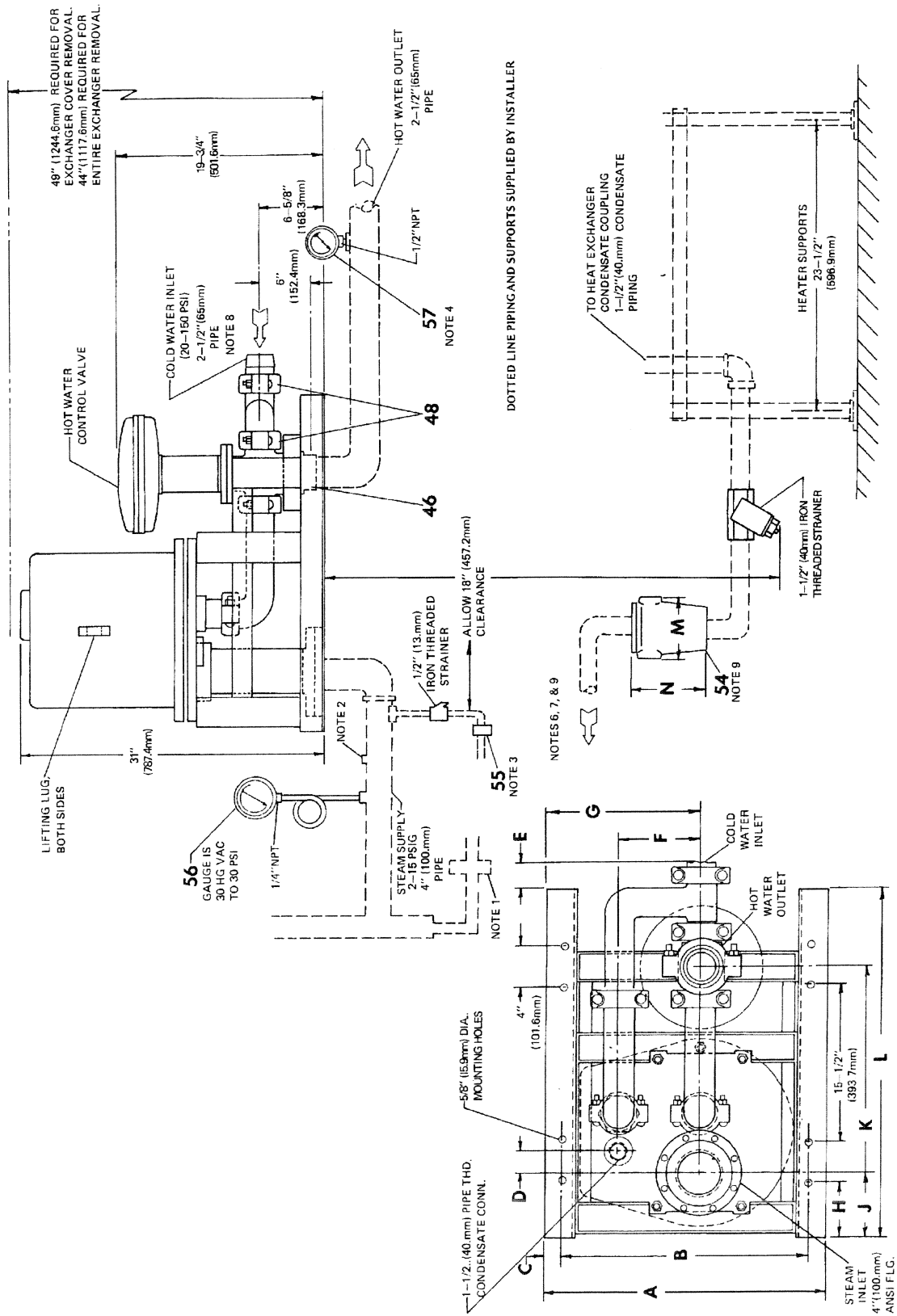

CONSTANTEMP HEATER, Models E-4500L, E-600L, E-900L, E-10500L, and E-1200L

MODEL		A	B	C	D	E	F	G	H	J	K	L	M	N
E-4500L, E-600L	in.	22-1/2	21	3/4	1	-3-7/8	6-7/8	12-1/2	4	5-7/16	17-13/16	31-1/2	1-1/2	2
	mm.	571.3	533.4	19.1	25.4	-98.4	174.6	317.5	101.6	138.1	452.4	800.1	38..1	50.8
E-7500L, E-900L	in.	24	21-1/2	1-1/4	1-13/16	3-7/8	6-7/8	10-3/4	2-15/16	9	13-15/16	29-7/16	2-1/2	2-1/2
	mm.	609.6	546.1	31.8	46	98.4	174.6	273	74.6	228.6	354	747.7	65	65
E-10500L, E-1200L	in.	27-13/16	24-5/16	1-3/4	2-13/16	2-3/8	8	15-1/4	5-7/16	7-7/16	19-31/32	34-3/8	2-1/2	2-1/2
	mm.	706.4	617.5	44.5	55.6	60.3	203	387.4	138.1	188.9	507.2	873.1	65	65

INSTALLATION CHECK LIST
NOTE 1: PROVIDE ADEQUATE DRIP LEG AND TRAP TO KEEP STEAM SUPPLY LINE FREE OF CONDENSATE.
NOTE 2: INSTALL SAFETY VALVE AT THIS CONNECTION WHEN STEAM SUPPLY PRESSURE MAY EXCEED 75 PSIG FOR DUCTILE IRON EXCHANGERS AND 150 PSIG FOR CAST STEEL EXCHANGERS.
NOTE 3: INSTALL SMALL TRAP AND STRAINER TO DRAIN CONDENSATION DURING NO LOAD OR STANDBY CONDITION.
NOTE 4: INSTALL THERMOMETER SUPPLIED IN OUTLET HOT WATER LINE.
NOTE 5: INSTALL STOP VALVES ON STEAM CONDENSATE AND WATER INLET AND OUTLET LINES.
NOTE 6: SEE TABLE FOR MAX. ELEVATION OF CONDENSATE DISCHARGE.
NOTE 7: CONDENSATE PIPING MUST BE ADEQUATE TO PREVENT EXCESSIVE BACK PRESSURE WHERE EXTRA ELBOWS OR LONG PIPE RUNS ARE USED, THE PIPE SIZE SHOULD BE INCREASED.
NOTE 8: INSTALL RELIEF VALVE IN COLD WATER SUPPLY LINE WHEN WATER PRESSURE MAY EXCEED 150 PSIG.
NOTE 9: SCREWED FITTING ON E-4500L, E-600L FLANGED FITTING ON E-900L, E-10500L & E-1200L

	E-4500L E-600L	E-7500L E-900L	E-10500L E-1200L
APPROXIMATE WEIGHT EXCLUDING STEAM TRAP	350 lb. 158.7 kg.	600 lb. 272.2 kg.	720 lb. 326.6 kg.
APPROXIMATE WEIGHT STEAM TRAP	27 lb. 12.2 kg.	35 lb. 15.9 kg.	47 lb. 21.3 kg.
HEATER MAY BE SUPPORTED BY FLOOR, SUSPENSION OR WALL BRACKET TYPE, FLOOR TYPE SHOWN			

MAXIMUM ELEVATION TABLE		
INLET STEAM PRESSURE (PSIG)	MAX. ELEV. COND. DISCHARGE	
2-4	0 ft.	0 cm
5-6	2 ft.	61. cm
7-8	4 ft.	121.9 cm
9-10	6 ft.	182.9 cm
10-12	8 ft.	243.8 cm
12-15	10 ft.	304.0 cm

CONSTANTEMP HEATER, Models E-4500L, E-600L, E-900L, E-10500L, and E-1200L

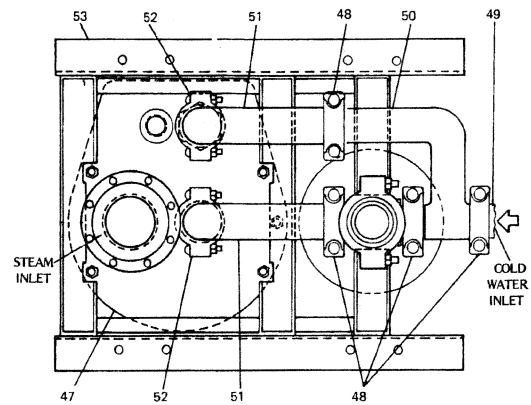
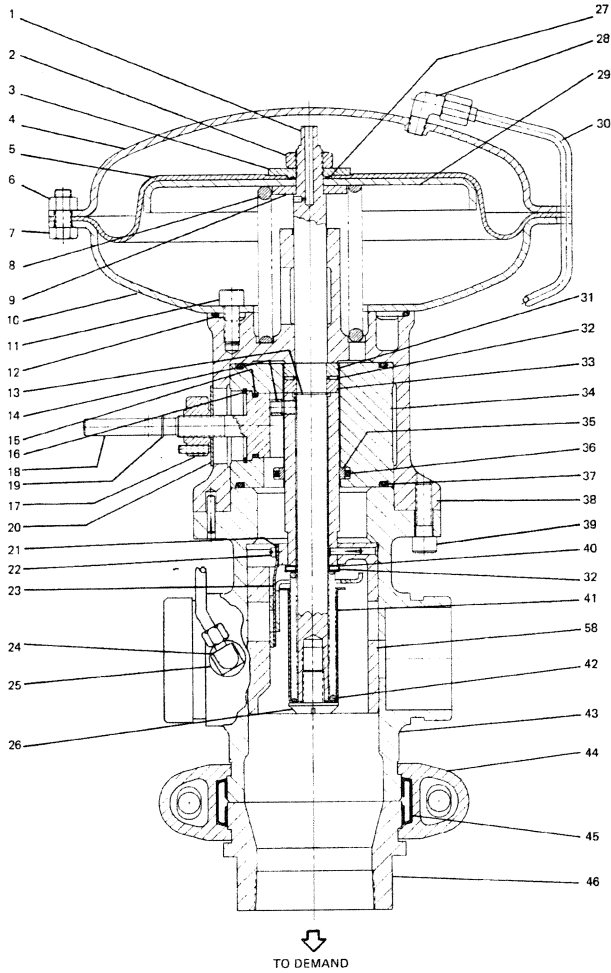

REFERENCE NUMBERS FOR PARTS NOT SHOWN ON DRAWING:

PART NAME	E-4500L	E-600L	E-7500L	E-900L	E-10500L	E-1200L
Copper Coil For Part No. 46**	011854097	011854087	011854098	011854088	011854099	011854089
Manifold Gasket For Part No. 46	72585	72585	72585	72585	72586	72586
Casing Gasket For Part No. 46	56686-67	56686-67	56686-67	56686-67	59551-67	59551-67
Coupling Gasket For Part No.47	58188	58188	58188	58188	—	—
Coupling Gasket For Part No. 48	56548	56548	58862	58862	58862	58862
Coil Lock Ring (Note 3)	61395	61395	61395	61395	61396	61396
Coil Lock Nut (Note 3)	59431	59431	59431	59431	60596	60596

** Coil kit includes coil, manifold gaskets, casing gasket, lock rings and locknuts.

MODEL NUMBER AND MATERIALS OF CONSTRUCTION:

MODEL NUMBER						DESCRIPTION
45GPM	60PGM	75GPM	90GPM	105GPM	120GPM	
E-4500L	E-600L	E-7500L	E-900L	E-10500L	E-1200L	Ductile Iron Shell, Copper Coils
E-4501L	E-601L	E-7501L	E-901L	E-10501L	E-1201L	Ductile Iron Shell, Admiralty Coils
E-4502L	E-602L	E-7502L	E-902L	E-10502L	E-1202L	Ductile Iron Shell, Cupro-Nickel Coils
E-4520L	E-620L	E-7520L	E-920L	E-10520L	E-1220L	Steel Shell, Copper Coils
E-4521L	E-621L	E-7521L	E-921L	E-10521L	E-1221L	Steel Shell, Admiralty Coils
E-4522L	E-622L	E-7522L	E-922L	E-10522L	E-1222L	Steel Shell, Cupro-Nickel Coils
E-4540L	E-640L	E-7540L	E-940L	E-10540L	E-1240L	Steel Shell, Copper Coils, ASME "U" Stamp
E-4541L	E-641L	E-7541L	E-941L	E-10541L	E-1241L	Steel Shell, Admiralty Coils, ASME "U" Stamp
E-4542L	E-642L	E-7542L	E-942L	E-10542L	E-1242L	Steel Shell, Cupro-Nickel Coils, ASME "U" Stamp
E-4550L	E-650L	E-7550L	E-950L	E-10550L	E-1250L	Steel Shell, Copper Coils, ASME "UM" Stamp
E-4551L	E-651L	E-7551L	E-951L	E-10551L	E-1251L	Steel Shell, Admiralty Coils, ASME "UM" Stamp
E-4552L	E-652L	E-7552L	E-952L	E-10552L	E-1252L	Steel Shell, Cupro-Nickel Coils, ASME "UM" Stamp

CONSTANTEMP HEATER, Models E-4500L, E-600L, E-900L, E-10500L, and E-1200L

PART NO.	PART NAME	MATERIAL	E4500L/E600L		E7500L/E900L		E10500L/E1200L	
			QTY. PER UNIT	REF NO.	QTY. PER UNIT	REF. NO.	QTY. PER UNIT	REF. NO.
1.	Upper Stem	Stainless Steel	1	6668	1	66693	1	66693
2.	Spring Guide Washer	Stainless Steel	1	64632	1	64632	1	64632
3.	Controlling Valve Spring	Stainless Steel	1	64747	1	66697	1	66697
4.	Nut	Steel	14	26585	14	26585	14	26585
5.	Bolt	Steel	14	37797	14	37797	14	37797
6.	Diaphragm Case-Lower	Stainless Steel	1	64443	1	64443	1	64443
7.	Socket H.D. Cap Screw	Steel	6	39655	6	39655	6	39655
8. *	O-Ring	Synthetic Rubber	1	64769-94	1	64769-94	1	64769-94
9. *	Spirolox Ring	Stainless Steel	1	59025	1	59025	1	59025
10.	Key Cylinder	Stainless Steel	1	58998	1	58998	1	58998
11. *	O-Ring	Synthetic Rubber	1	59052-94	1	51167-94	1	51167-94
12. *	Retaining Ring	Stainless Steel	1	59023	1	59494	1	59494
13.	Lock Nut-Complete	Brass	1	59001	1	59001	1	59001
14. *	Gain Adjustor	Stainless Steel	1	58995	1	59291	1	59291
15. *	Retaining Ring	Copper	1	59024	1	59024	1	59024
16.	Cover Plate	Brass	1	59009	1	59314	1	59314
17.	Screw	Stainless Steel	2	70929	2	24755	2	24755
18.	Lockwasher	Stainless Steel	2	70930	2	21666	2	21666
19.	Spring Seat Washer	Stainless Steel	2	59013	2	59013	2	59013
20.	Relief Valve	Brass	1	59121	1	59121	1	59121
21.	Seal Plate Assembly	Stainless Steel	1	59031	1	63996	1	63996
22.	Screw	Bronze	1	59486	1	59486	1	59486
23.	Jam Nut	Steel	1	50547	1	50547	1	50547
24. *	O-Ring	Synthetic Rubber	1	49746-94	1	49746-94	1	49746-94
25.	Shouldered Washer	Stainless Steel	1	64645	1	64645	1	64645
26. *	Diaphragm	Synthetic Rubber	1	37809-94	1	37809-94	1	37809-94
27.	Diaphragm Case-Upper	Stainless Steel	1	64442	1	64442	1	64442
28.	Male Elbow-Flared	Brass	1	64829	1	64829	1	64829
29.	Diaphragm Plate	Stainless Steel	1	64641	1	64641	1	64641
30.	Formed Tubing	Copper	1	66690	1	66695	1	66696
31.	Stem Collar Washer, Upper	Stainless Steel	1	59014	1	59489	1	59489
32.	Thrust Washer	Graphite Filled Teflon or Stainless Steel	1	59015	1	68484	1	68484
33. *	Temp. Adjusting Sleeve Compl.	Stainless Steel	1	58989	1	59288	1	59288
34.	Guide	Graphite Filled Teflon	1	59107	1	59312	1	59312
35. *	Guide Energizer	Synthetic Rubber	1	59166	1	59166	1	59166
36.	Yoke	Cast Bronze	1	66686	1	66691	1	66691
37.	O-Ring	Synthetic Rubber	2	59029-94	2	59495-94	2	59495-94
38. *	Valve Plug Complete Note 3	Monel	1	73463	1	73460	1	73460
39.	Cap Screw	Steel	(Note 1)	(Note 1)	(Note 2)	(Note 2)	(Note 2)	(Note 2)
40.	Needle Bearing	Nylon & Stainless Steel	1	59440	1	68484	1	68484
41. *	Yielding Spring	Stainless Steel	1	59019	1	59299	1	59299
42.	Body	Cast Bronze	1	58985	1	59294	1	59294
43.	Coupling	Malleable Iron	1 - 3"	55569	1 - 3-1/2"	59491	1 - 3-1/2"	5949
44. *	Gasket	Commercial	1	56237	1	59492	1	59492
45.	Reducing Coupler	Cast Bronze	1	55483	1	59285	1	59285
46.	Ht. Exchg., E4500L/E7500L/E10500L	Ductile Iron/Copper Coil	1	71703	1	71704	1	71705
46.	Ht. Exchg., E600L/E900L/E1200L	Ductile Iron/Copper Coil	1	68610	1	68611	1	68612
46.	Ht. Exchg., E4520L/E7520L/E10500L	Steel/Copper Coil	1	717032022	1	717042022	1	717052022
46.	Ht. Exchg., E600L/E900L/E1200L	Steel/Copper Coil	1	686102022	1	686112022	1	686122022
47.	Coupling	Malleable Iron	3 - 2"	58187	2 - 2"	58187	—	—
48.	Coupling	Malleable Iron	3 - 1-1/2"	56547	4 - 2-1/2"	58860	6 - 2-1/2"	58860
49.	Mounting Frame	Carbon Steel	1	64948	1	60797	1	59200
50.	U-Bolt With Nuts	Steel	1	58654	—	—	—	—
51.	1-1/2" F + T Trap	Cast Iron	1	72341	1	72341	1	72341
52.	Pressure Gauge	Steel Case	1	63092	1	63092	1	63092
53.	1/2" Steam Trap	Cast Iron	1	70653	1	70653	1	70653
54.	Thermometer	Stainless Steel	1	60184	1	60184	1	60184
55.	1-1/2" Strainer	Cast Iron	1	F000220056W	1	F000220056W	1	F000220056W
56.	1/2" Strainer	Cast Iron	1	F000220051W	1	F000220051W	1	F000220056W
57.	Actuating Cylinder	Stainless Steel	—	—	1	63993	1	63993
58.	Nipple	Brass	1	58189	1	59361	1	59361
59.	Inlet Manifold	Cast Bronze	1	58170	1	60798	1	59287
60.	Exchanger Manifold	Cast Bronze	2	58169	2	60799	2	59286
61.	Fitting (Male Elbow)	Brass	1	64770	1	64770	1	64770
62.	Pigtail Siphon	Cast Iron	1	56745	1	56745	1	56745
63.	Stem Thrust Washer, Lower	Graphite Filled teflon or Stainless Steel	1	59014	1	68484	1	59493

NOTE 1: Requires four (4) R/N 45840 and two (2) R/N 59478.

NOTE 2: Furnished with Heater Coil but may be ordered separately.

NOTE 3: Includes seal plate (#21), screws (#17) and lock washers (#18)

* Recommended spare parts.

* These parts should be on hand, plus recommended spare parts, when overhauling equipment.

Re-Circulation Switch Connection Diagram

ATTENTION

Enclosed is a safety shut-off switch kit for use with the re-circulation system installed on your Leslie Constantemp Heater. This switch adds an additional measure of safety by shutting down the pump in the re-circulation line in the event of an over temperature situation.

This shut-off switch can be installed anywhere in the re-circulation line and should be wired as illustrated below. Please conform to all local and federal codes and guidelines in connecting this switch.

Please contact one of our Leslie Service Centers or the Leslie World Headquarters located in Tampa, Florida for additional information or installation guidelines.

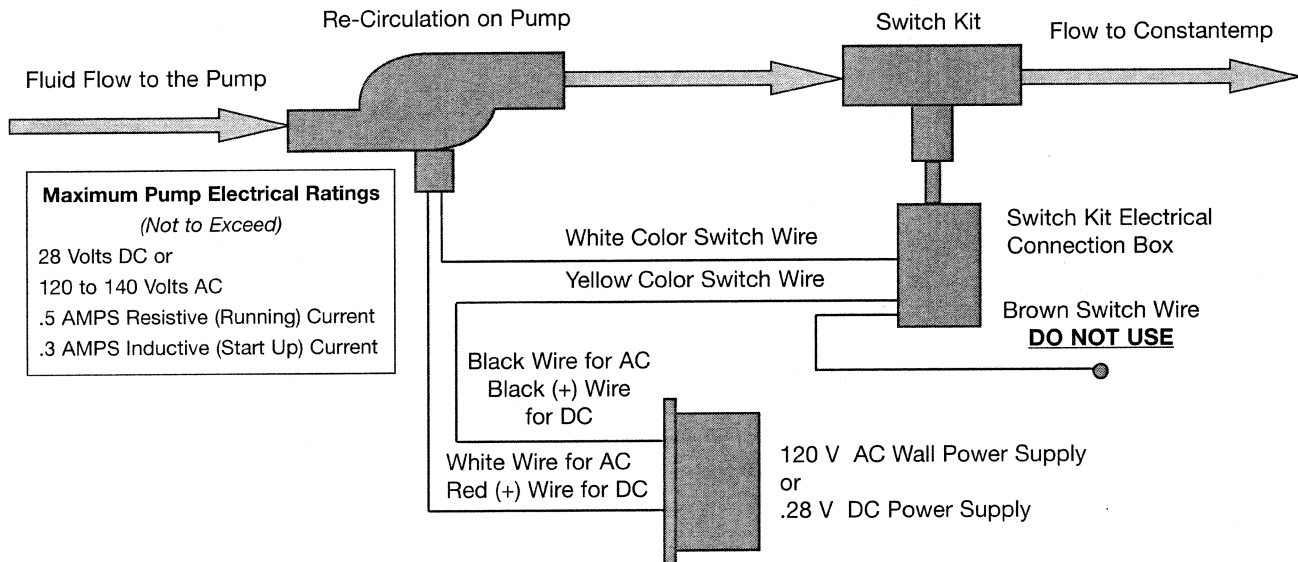

A subsidiary of CIRCOR International, Inc.
12501 Telecom Drive • Tampa, FL 33637-0906

Ph: (813) 978-1000 • Fax: (813) 978-0984
www.lesliecontrols.com