

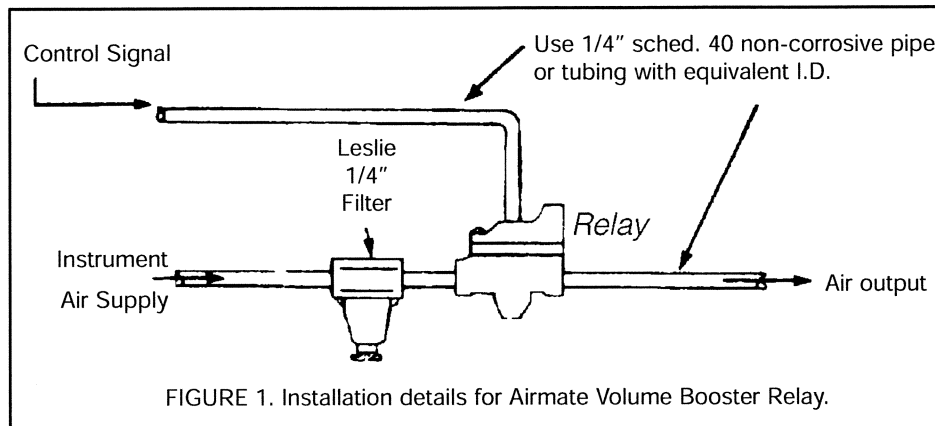

LESLIE-AIRMATE PNEUMATIC RELAYS Volume Boosting



SECTION I—INSTALLATION

Install as shown in figure 1. Use non-corrosive piping or tubing and fittings throughout. Use Leslie 1/4" filter or strainer with poromet filter.

SECTION II—OPERATION

1. Turn on air supply and control signal to the relay.
2. Adjust relay, when necessary, as follows:

1:1B VOLUME BOOSTER RELAYS (figure 2). Adjust needle valve (36) to produce bleed action desired. Turn needle valve clockwise to decrease bleed; counterclockwise to increase bleed.

SECTION III—MAINTENANCE

NOTE: MAIN BODY ASSEMBLIES WITH COMPONENT PARTS ARE SIMILAR IN ALL RELAYS MENTIONED IN THIS INSTRUCTION.

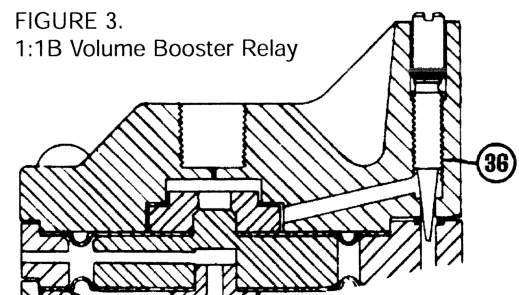
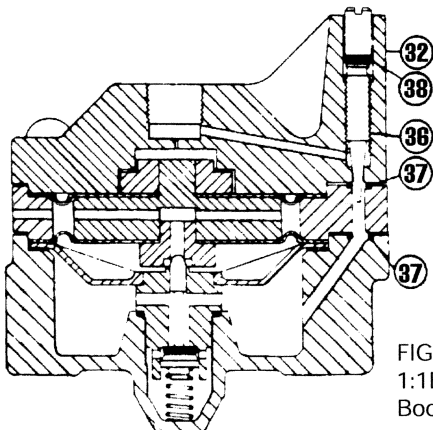

Dismantling

1. Shut off air supply and control signal. Disconnect control signal line at cover (32).
2. Remove screws. Lift off cover (32), diaphragm assembly (parts 10, 11, 13, and 34) and vent chamber (35).
3. Grip internal rib of aspirator plate (14) with narrow nosed pliers at point marked "Lift Here" and lift aspirator plate out of main body (15). Remove gasket (12). Unscrew valve seat (16) with "O" ring (17) from main body. Lift out main valve (18) with "O" ring (19) and main valve spring (20).

Cleaning or Replacing Parts

Clean all parts with a detergent non-injurious to synthetic materials. Wipe dry with clean cloth. Make sure port areas are free and clear. Replace any worn or damaged parts.

Reassembling

1. Place main valve spring (20) in main body. Place "O" ring (17) on valve seat (16). Assemble main valve (18) with "O" ring (19) in valve seat (16). Screw valve seat with parts into main body and tighten.
2. Place gasket (12) in recess of main body. Insert aspirator plate (14) with aspirator tube in outlet side. Snap aspirator plate in place (16) with finger pressure. Place nozzle/diaphragm assembly in main body with disc (10) upward. Position diaphragm assembly, (parts 10,11,13 and 34) on main body.

In diaphragm assembly (parts 10, 11, 13 and 34) diaphragms are pre-assembled to diaphragm spacer (34). When assembling vent chamber (35) to main body bend upper diaphragm carefully upward around diaphragm disc (10) so that vent chamber will clear upper diaphragm as it is placed on main body. Then allow diaphragm to fall into its position.

3. Assemble cover (32) to vent chamber. Tighten firmly
4. Reconnect Pneumatic lines and place into operation.

MAINTENANCE OF FILTER ASSEMBLY

To clean or replace filter (23). Disassemble filter Case (26) and gasket (12) from cover (32). Separate filter (23) and filter support disc (25) from filter case. Clean all parts thoroughly. Replace filter if necessary.

To reassemble. Place filter support disc (25) and filter (23) in filter case (26). Assemble gasket (12) and filter case (26) to cover (32). Insert screws and tighten.

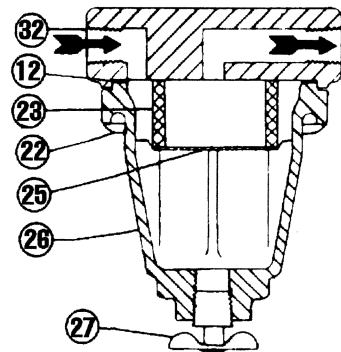

RELAY 1:1 VOLUME BOOSTING

| PART NO. | PART NAME | MATERIAL | QTY. PER UNIT | REF. NO. |
|----------|---------------------|-------------------------|---------------|----------|
| 7 | Screw, Phillips Hd. | Steel, Cad. Plated | 4 | 53674 |
| 10 | Diaphragm Disc** | Celcon | 1 | 55244 |
| 11 | Diaphragm** | Synthetic Rubber | 2 | 58066 |
| 12 | Gasket | Synthetic Rubber | 1 | 52992 |
| 13 | Nozzle** | Delrin* (Acetal Resin) | 1 | 54726 |
| 14 | Pilot Plate | Celcon | 1 | 52899 |
| 15 | Main Body | Aluminum | 1 | 52664 |
| 16 | Valve Seat | Aluminum | 1 | 52676 |
| 17 | O-Ring | Synthetic Rubber | 1 | 51162 |
| 18 | Main Valve, Comp. | Celcon | 1 | 54488 |
| 19 | O-Ring | Polyurethane 1 | 54458 | |
| 20 | Main Valve Spring | Music Wire, Cad. Plated | 1 | 55248 |
| 32 | Cover | Cast Aluminum | 1 | 54719 |
| 34 | Diaphragm Spacer** | Aluminum | 1 | 54707 |
| 35 | Vent Chamber | Cast Aluminum | 1 | 54703 |

* E. I. du Pont de Numours & Co., Inc.

** Note: Part No.'s 10, 11, 13 & 34 furnished only as Diaphragm Nozzle Disc Complete. Ref. No. 60668.

PATENTED

☛ = Recommended Spare Parts

★ = These parts should be on hand, plus recommended spare parts, when overhauling this equipment.

INPUT SIGNAL AND OUTPUT PRESS.

Ranges 1-150 PSI

Max. Temp. 150° F

Supply Press. Range 15 PSI above highest output, 200 PSI max.

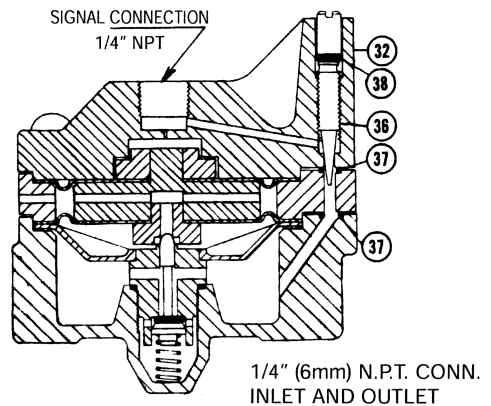
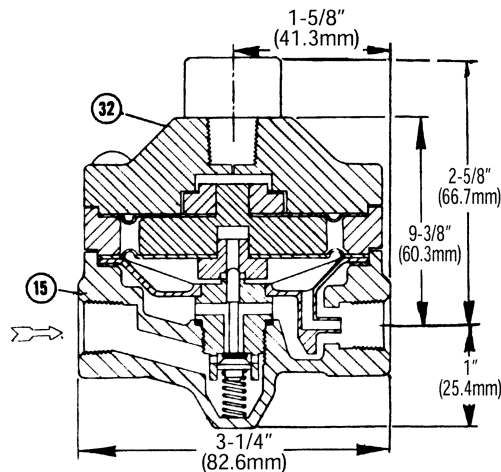
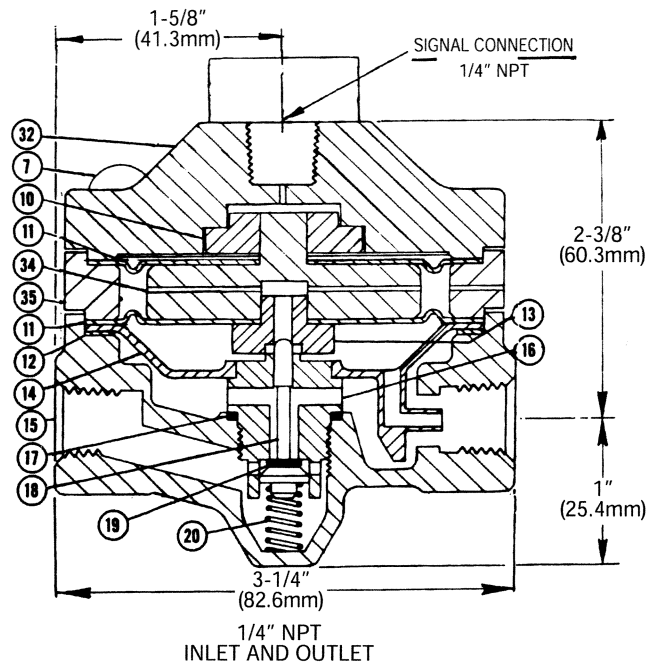

| PART NO. | PART NAME | MATERIAL | QTY. PER UNIT | REF. NO. |
|----------|--------------|------------------|---------------|----------|
| 15 | Main Body | Aluminum | 1 | 54731 |
| 32 | Cover | Cast Aluminum | 1 | 54720 |
| 36 | Needle Valve | Stainless Steel | 1 | 54728 |
| 37 | O-Ring | Synthetic Rubber | 2 | 54737 |
| 38 | O-Ring | Synthetic Rubber | 1 | 23869 |

INPUT SIGNAL AND OUTPUT PRESSURE RANGER 1 - 150 PSI
MAX. TEMP. 150° F.

All parts not shown same as 1:1 Relay

RELAY 1:1B VOLUME BOOSTING

MOUNTING BRACKET
(for all relays)
Furnished on request only
Ref. No. 56222
Mat'l - Steel

SUPERSEDES DWG. NO. CP-20325F

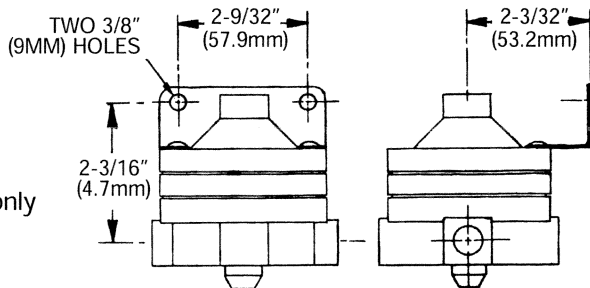

| | | | |
|---|--------|-------|---------------------|
| LESLIE CONTROLS, INC. TAMPA, FL 33637 | | | |
| LESLIE- AIRMATE RELAYS AND FILTER | | | |
| DATE | APP'D. | D'W'N | DWG. NO. |
| 6-11-81 | JR | BW | 20/6.4.1 ALT. 10 |
| PRINTED IN USA 790W 5C | | | |

RELAY 1:3 (DIVIDING)

☛ RECOMMENDED SPARE PARTS

RELAY 1:3 (MULTIPLYING)

| PART NO. | PART NAME | MATERIAL | QTY. PER UNIT | REF. NO. |
|----------|------------------|------------------|---------------|----------|
| 34 | Diaphragm Spacer | Aluminum | 1 | 54708 |
| 35 | Vent Chamber | Cast Aluminum | 1 | 54705 |
| ☛41 | Diaphragm, Upper | Synthetic Rubber | 2 | 58067 |
| ☛42 | Diaphragm, Lower | Synthetic Rubber | 1 | 58066 |

1/4" (6mm) N.P.T. CONN. INLET AND OUTLET

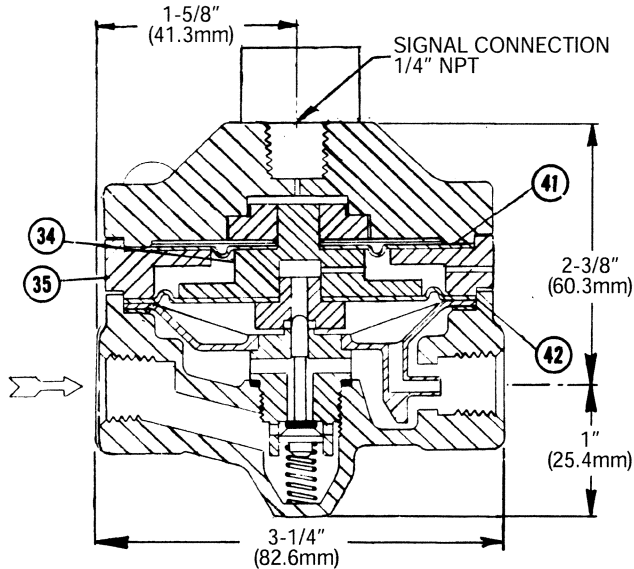

INPUT SIGNAL PRESSURE RANGE = 1- 150 PSI
 OUTPUT PRESSURE RANGE = 1- 50 PSI
 MAXIMUM TEMPERATURE = 150° F

| PART NO. | PART NAME | MATERIAL | QTY. PER UNIT | REF. NO. |
|----------|------------------|------------------|---------------|----------|
| 34 | Diaphragm Spacer | Aluminum | 1 | 55245 |
| 35 | Vent Chamber | Cast Aluminum | 1 | 54706 |
| ☛41 | Diaphragm, Upper | Synthetic Rubber | 2 | 58066 |
| ☛42 | Diaphragm, Lower | Synthetic Rubber | 1 | 58067 |

1/4" (6mm) N.P.T. CONN. INLET AND OUTLET

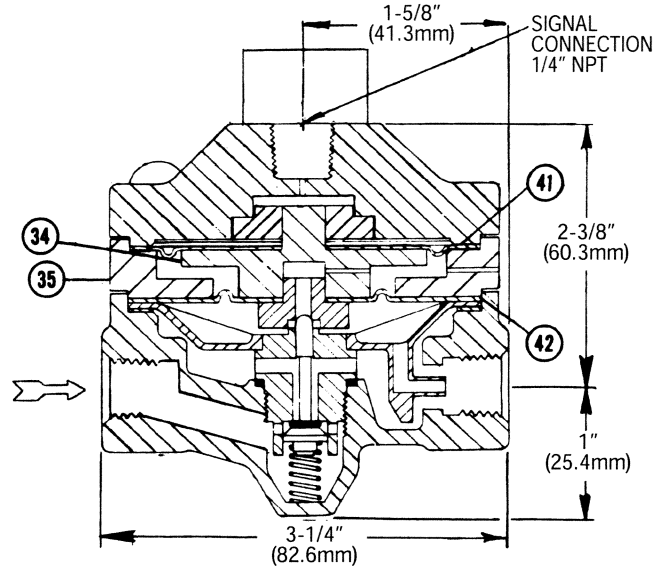

INPUT SIGNAL PRESSURE RANGE = 1- 50 PSI
 OUTPUT PRESSURE RANGE = 1- 150 PSI
 MAXIMUM TEMPERATURE = 150° F

RELAY 1:1D BIASING

| PART NO. | PART NAME | MATERIAL | QTY. PER UNIT | REF. NO. |
|----------|-------------------|------------------------|---------------|----------|
| 2 | Nut | Steel, Cad. Plated | 1 | 24772 |
| 4 | Top Spring Seat | Brass | 1 | 20571 |
| 6 | Adj. Spring | Spring Steel, Cad. Pl. | 1 | 33974 |
| 7 | Diaphragm Disc | Celcon | 1 | 11689 |
| 8 | Spring Case Assy. | Aluminum | 1 | 54960 |
| 39 | Lock Nut | Steel | 1 | 11689 |
| 40 | Adj. Screw | Stainless Steel | 1 | 54740 |
| 43 | Sealing Washer | Steel Cad. Plated | 1 | 58358 |

INPUT SIGNAL AND OUTPUT PRESS.
 RANGE 1-150 PSI MAX. TEMP. 150° F

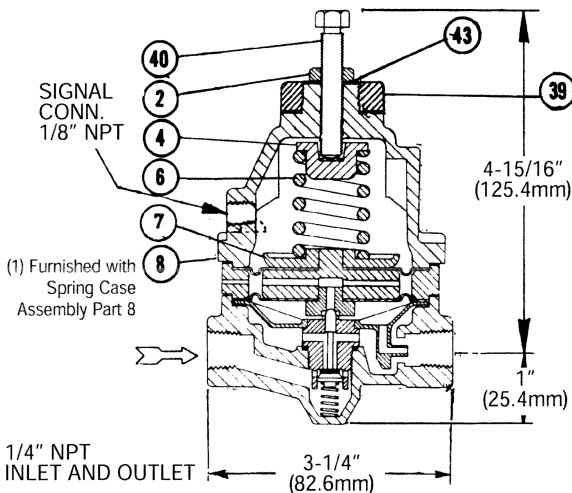

1/4" NPT
 INLET AND OUTLET

FILTER

| PART NO. | PART NAME | MATERIAL | QTY. PER UNIT | REF. NO. |
|----------|---------------------|--------------------|---------------|----------|
| ☛12 | Gasket | Synthetic Rubber | 1 | 52992 |
| 22 | Screw, Phillips Hd. | Steel, Cad. Plated | 1 | 52993 |
| ☛23 | Filter, 5-10 Micron | NOTE 1 | 1 | 52936 |
| 25 | Filter Support Disc | Stainless Steel | 1 | 52990 |
| 26 | Filter Case | Aluminum | 1 | 52991 |
| 27 | Drain Cock | Brass | 1 | 58269 |
| 32 | Cover | Cast Aluminum | 1 | 54751 |

NOTE 1 - Resin Impregnated Cellulose

MAX. INLET PRESSURE - 200 PSI / MAX. TEMPERATURE - 150° F

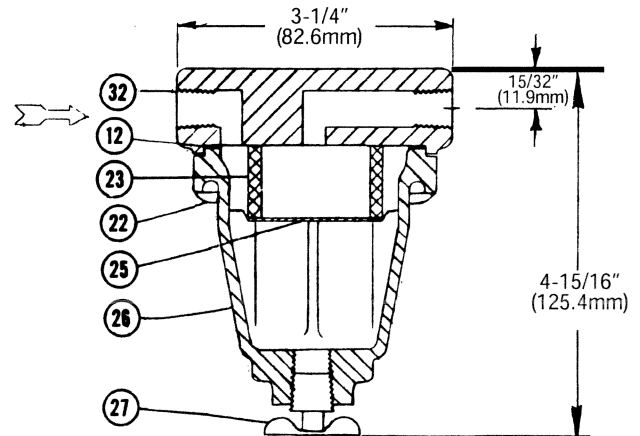

RECOMMENDED SPARE PARTS KIT - REF. NO. 001 9113 02

QTY. 10 - PART 12, REF. NO. 52992
 QTY. 10 - PART 23, REF. NO. 52936

20/6.4.1
 ALT.10