

## Installation and Service Instruction

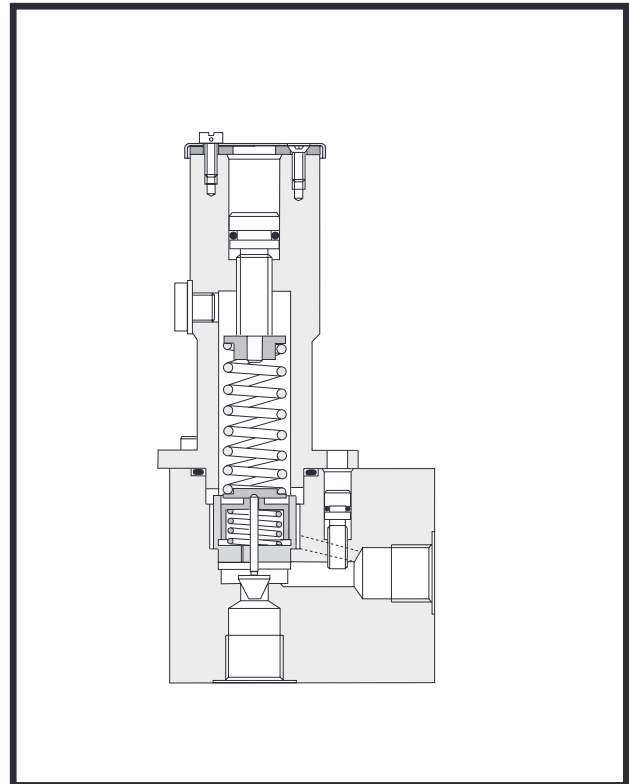

This instruction is valid for all GA-valves

Contents	Page
Valve identification/Installation	2
Start-up/Trouble shooting	4
Sectional view	5
List of components/Ordering code	6
Useful tools/GAD springs	7
GAR/GAS dismantling/reassembly	8
GAD dismantling/reassembly	10

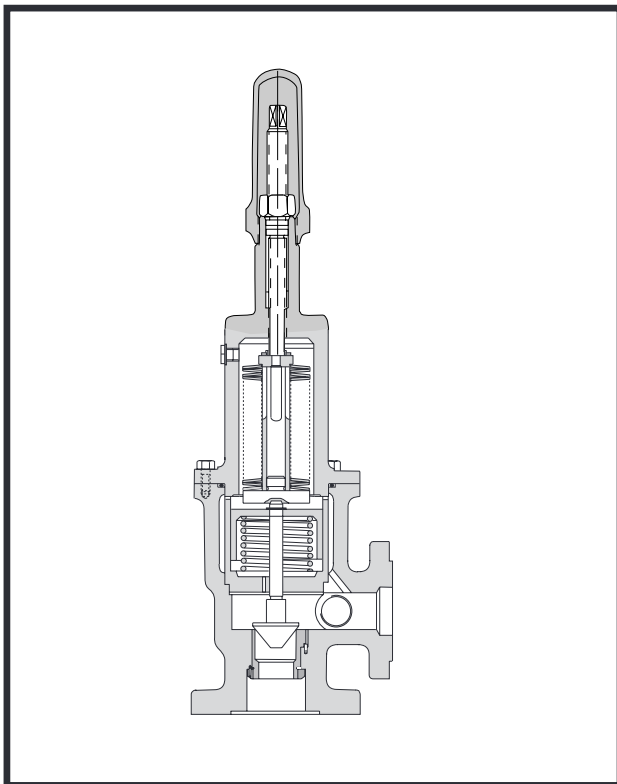

Before commencing any work, read this instruction carefully! Failure to comply with these instructions may cause damage and personal injury!

These instructions are valid for all valves as specified in the **Valve identification chart** below.

# Valve identification

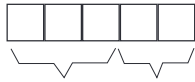
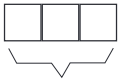

Valve name	Size	Generation	Valve spring pressure	Valid for option	Comments
GAR	012 034 100 112	01	T008 T040 T075 T100	A078 A308 A313	Threaded pipe connections
GAS	015 020 025 040				SAE flanged pipe connections
GAD	065				DIN flanged pipe connections

### Identification of safety instructions

Non compliance of safety instructions identified by the following symbol - could affect safety for persons.



Safety instructions where electrical safety is involved, are identified by:



Safety instructions which shall be considered for reasons of safe operation of the valve unit and/or protection of the valve unit itself are marked by the sign:

**ATTENTION**

# Installation

**BEFORE COMMENCING ANY WORK, READ THIS INSTRUCTION CAREFULLY!**

Design limitations and technical data for each valve are found in the **Product description**.

Installation of IMO AB valves does not require special skills. However, these instructions presume that the work is carried out by experienced fitters.



**Failure to comply with these instructions may cause damage and personal injury!**



**All work carried out on the valve has to be performed in such a manner that risks for personal injury are observed!**

## Transport and storage

Always protect the valve against ingress of water and other impurities. Store the valve in a clean, dry and warm environment. The valve is delivered with the internals oiled and with protective covers over the pipe connections. These covers should remain in place for as long as possible during the mounting and installation procedure.

## Mounting

The valve can be mounted in any position, horizontally or vertically. It should be mounted as close as possible to the unit it shall protect or control. It is preferred that the outlet connection is led back to the tank. See fig. 1.

In any case the return connection should not be connected to the pump suction line as this might result in overheating and too high volume of free gas entering the pump. If long pipes are connected to the valve the friction losses in the pipes might interfere with the valve performance in which case bigger pipe dimensions should be considered.

 When handling liquids that may harm skin use gloves and/or protective clothing.

 When handling liquids which may involve fire hazards appropriate precautions to avoid danger are to be taken.

## Pressure testing and flushing

The system must be flushed and pressure tested before connecting the valve. If corrosive liquid, such as water is used for the test, the system must be thoroughly drained, dried and protected against corrosion after having been flushed.

 Oil leakage may make the floor slippery and cause personal injury.

## Deaeration

In installations with positive head on the outlet port, the valve must be deaerated at start, or whenever it can be assumed that the valve has been emptied (see fig 2).

 If operating temperature exceeds 60°C (149°F), appropriate measures to avoid burn injury shall be provided.

 Use hearing protections whenever high noise can be expected from pump, motor and/or environment.

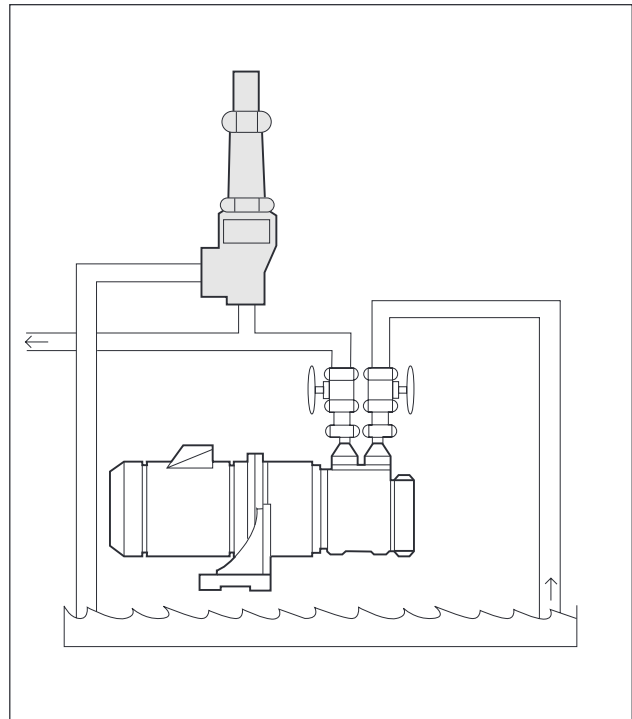

Fig. 1

## Pipe connections

The pipe work should be installed and supported so as not to exert any significant load and transfer it on the valve housing.

The pipe work should be tight in order to avoid leakage and infiltration of foreign particles and/or air.

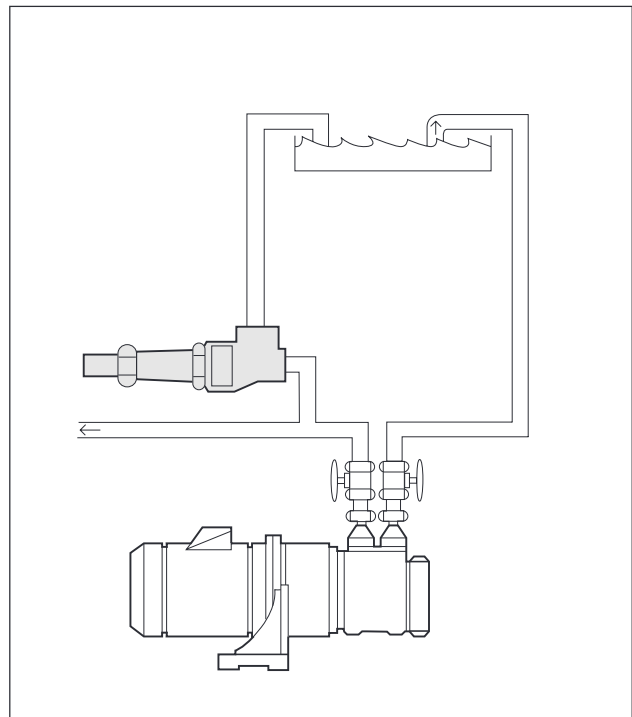

Fig. 2

# Start-up

## Before starting

Check that all valves necessary for the operation are fully open and set the pressure to minimum by turning the set screw CCW.

## Starting

Start the pump (or system).

Deaerate the valve and slowly increase the pressure to the desired value by using the set screw.

In horizontal installations with the outlet downwards and in vertical installations this is done by opening the deaeration plug on the spring housing a few turns and when liquid is coming out, closing the plug.

In horizontal installations with the outlet upwards the deaeration will be done automatically.

If the valve does not work properly see "Trouble shooting".

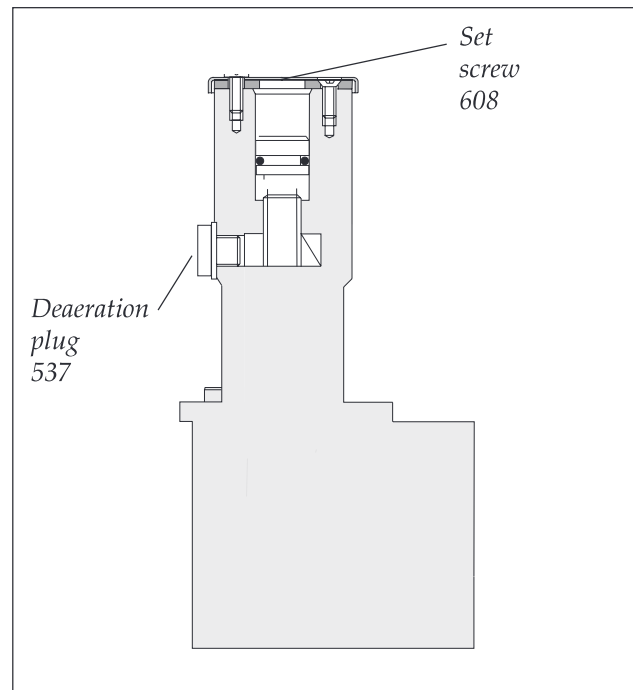

Fig. 3

# Trouble shooting

Problem	Cause	What to do
<b>Pressure too low</b>	<ul style="list-style-type: none"> <li>- The pressure relief valve is set too low.</li> <li>- Counter pressure in the pump discharge line is too low due to a major leakage.</li> <li>- The valve piston of the pressure relief valve is stuck in open position.</li> <li>- The valve is too small.</li> <li>- Improper valve spring.</li> </ul>	<p>Re-adjust the pressure relief valve.</p> <p>Check the components in the discharge line inclusive the recipients.</p> <p>Check the valve. See under "dismantling".</p> <p>Contact your IMO AB representative. Contact your IMO AB representative.</p>
<b>Pressure too high</b>	<ul style="list-style-type: none"> <li>- The pressure relief valve is set too high.</li> <li>- The valve is too big.</li> </ul>	<p>Re-adjust the pressure relief valve.</p> <p>Contact your IMO AB representative.</p>
<b>Pressure is fluctuating "Hunting"</b>	<ul style="list-style-type: none"> <li>- Trapped air in the valve</li> <li>- Too high viscosity.</li>   <li>- Liquid too cold.</li>   <li>- Valve internals damaged due to wear or corrosion.</li> </ul>	<p>See "Starting"</p> <p>The compensation in the valve is too high for the conditions. The Compensator piston must be adjusted. Contact your IMO AB representative.</p> <p>Run the system till operating temperature is reached. If problem still remains, see above.</p> <p>Open the valve. See under "Dismantling".</p>
<b>Pressure accumulation too big</b>	<ul style="list-style-type: none"> <li>- The throttle screw is not tuned to the system.</li> </ul>	<p>Adjust the throttle screw 647 CW.</p>
<b>Pressure drops below set value when overflow increases</b>	<ul style="list-style-type: none"> <li>- The throttle screw is not tuned to the system.</li> </ul>	<p>Adjust the throttle screw 647 CCW.</p>

# Sectional view

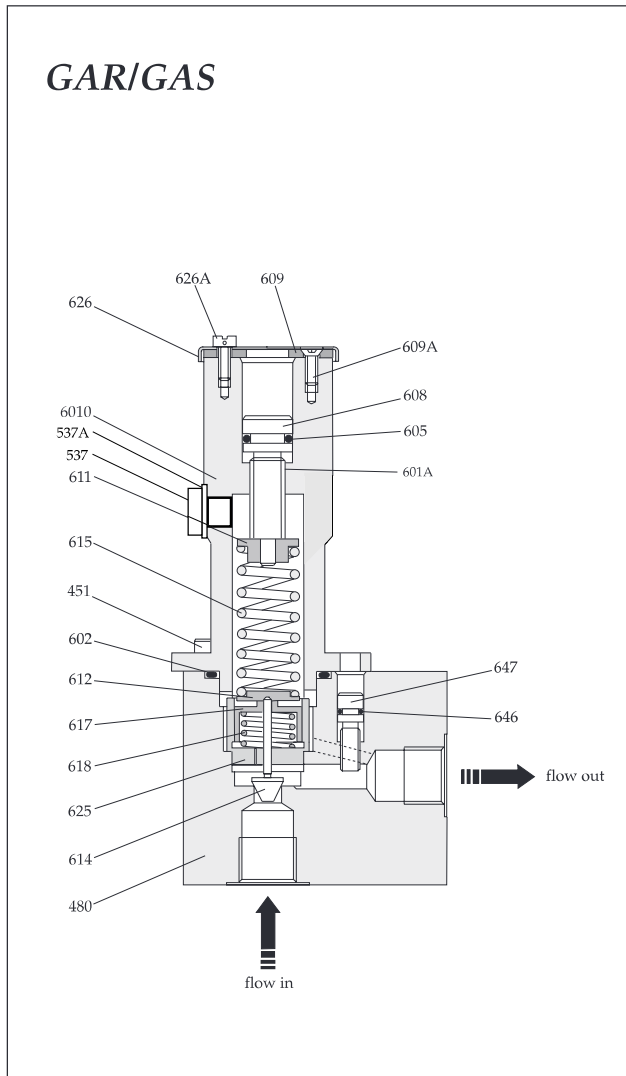

Fig. 4

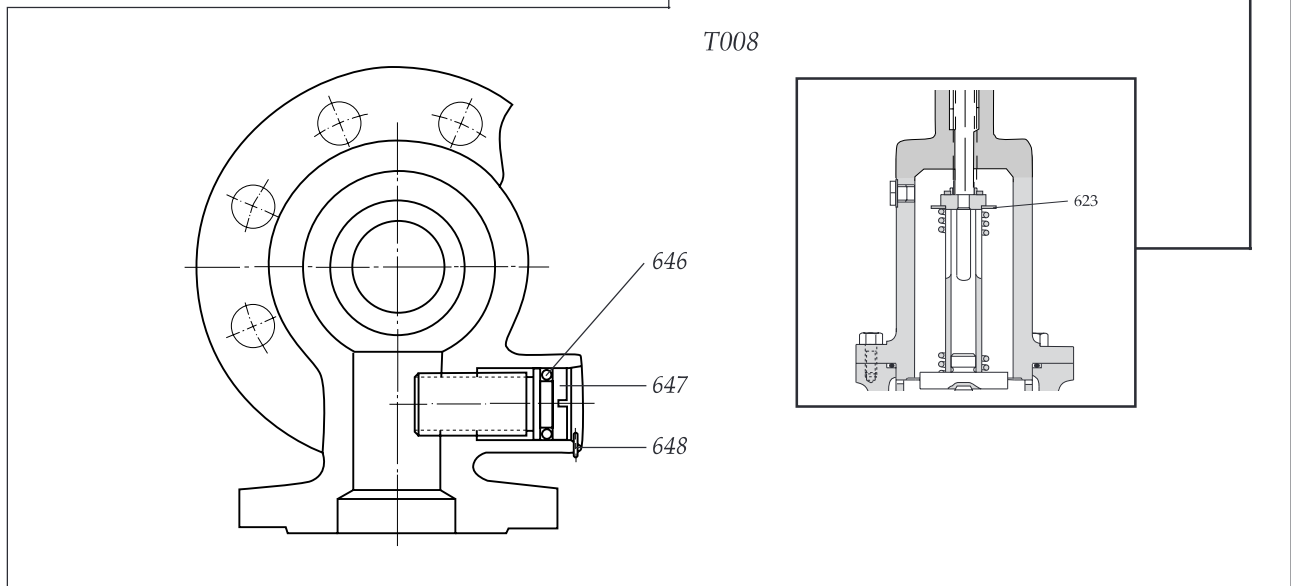
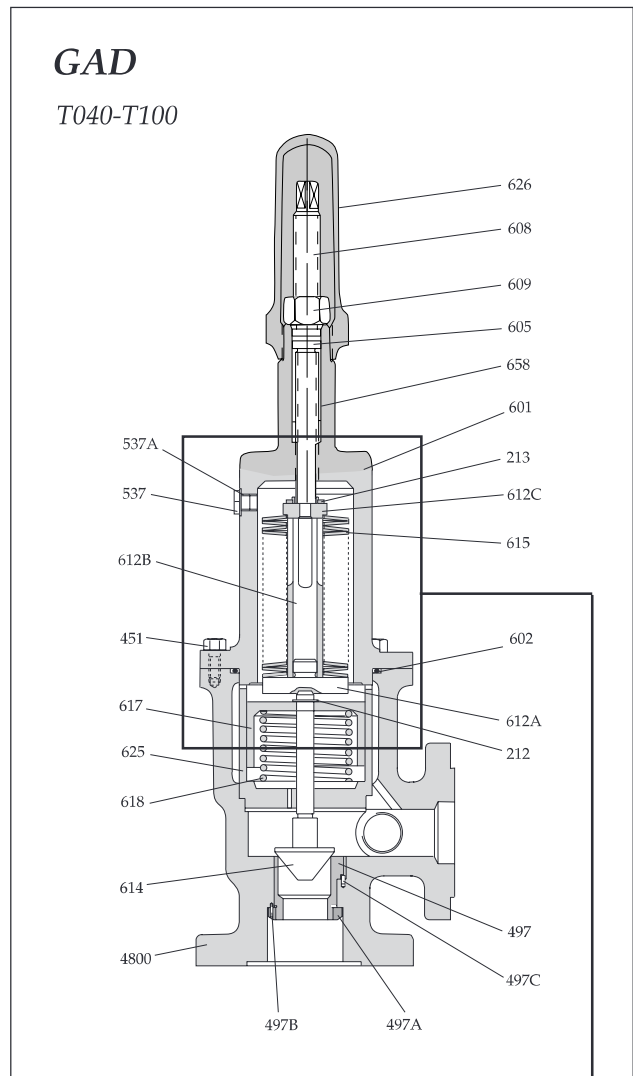

Fig. 5

# List of components

Item	Denomination	Qty	GAD	GAR	GAS	Note
212	Retaining ring	1	x			
213	Retaining ring	1	x			
423	O-ring	2				1
427	Split flange	4				1
427A	Pipe weld	2				1
428	Screw	8				1
428A	Washer	8				1
451	Screw	4/8	x	x	x	
4800	Valve housing	1	x	x	x	
497	Valve seat	1	x			
497A	Nut	1	x			
497B	Tension pin	1	x			
497C	Pin	1	x			
537	Deaeration plug	1	x	x	x	
537A	Sealing washer	1	x	x	x	
601	Valve cover	1	x	x	x	
601A	Threading adapter	1		x	x	2
602	O-ring	1	x	x	x	
605	O-ring	1	x	x	x	
608	Set screw	1	x	x	x	
609	Stop washer	1		x	x	
609	Nut	1	x			
609A	Screw	2		x	x	

Item	Denomination	Qty	GAD	GAR	GAS	Note
611	Set screw washer	1		x	x	
612	Spring washer	1		x	x	
612A	Spring washer	1	x			
612B	Sleeve	1	x			
612C	Spring washer	1	x			
614	Poppet	1	x	x	x	
615	Valve spring	1	x	x	x	4
615	Valve spring	1	x			3
617	Compensator piston	1	x	x	x	
618	Auxiliary spring	1	x	x	x	
623	Stop washer	1	x			5
625	Compensator sleeve	1	x	x	x	
626	Cap	1	x	x	x	
626A	Screw	2		x	x	
627	Sealing washer	1	x			
646	O-ring	1	x	x	x	
647	Throttle screw	1	x	x	x	
648	Tension pin	1	x			
658	Distance sleeve	1	x			

- Remarks: 1) Accessories to one GAS valve  
 2) Included in valves GAR 100 and 112, GAS 025 and 040  
 3) Valid for GAD T040, T075 and T100 \*  
 4) Valid for GAD T008, all GAR and GAS versions  
 5) Valid for GAD T008

\* See fig. 7 on page 7 for amount of washers included

## Ordering code

Item	Denomination	Part. No GAR 012 GAS 015	Part. No GAR 034 GAS 020	Part. No GAR 100 GAS 025	Part. No GAR 112 GAS 040	Part. No GAD 065		
	Valve	GAR T008	135244	134049	134346	134973	--	
	"	GAR T040	135236	134031	134338	134965	--	
	"	GAR T075	135228	134023	134320	134957	--	
	"	GAR T100	149112	141192	145201	153924	--	
	"	GAS T008	136085	136119	136143	136176	--	
	"	GAS T040	136077	136101	136135	136168	--	
	"	GAS T075	136069	136093	136127	136150	--	
	"	GAS T100	189495	145409	143867	144394	--	
	"	GAD T008	--	--	--	--	132928	
	"	GAD T040	--	--	--	--	132902	
	"	GAD T075	--	--	--	--	132894	
	"	GAD T100	--	--	--	--	132910	
423	O-ring *	152447	016717	016733	016782	--	--	
602	O-ring *	016741	016766	016790	016857	016956	--	
605	O-ring *	016675	016675	016675	144519	152447	--	
614	Poppet	052506	052654	052829	053017	053199	--	
615	Valve spring	T008	022426	022533	022590	022665	095240 **	
	"	T040	022400	022517	022574	022640	022699 **	
	"	T075	022392	022491	022558	022624	022681 **	
	"	T100	022418	022525	022582	022657	022681 **	
617	Compensator piston	052514	052662	052837	053025	053207	--	
618	Spring T040/075/100	022442	022509	022566	022632	022715	--	
	"	T008	022459	022541	022608	022673	022723	--
625	Compensator sleeve	052522	052670	052845	053033	053215	--	
627	Sealing washer	--	--	--	--	--	017889	
646	O-ring *	146076	146076	088062	144519	016725	--	

# Useful tools

# O-rings

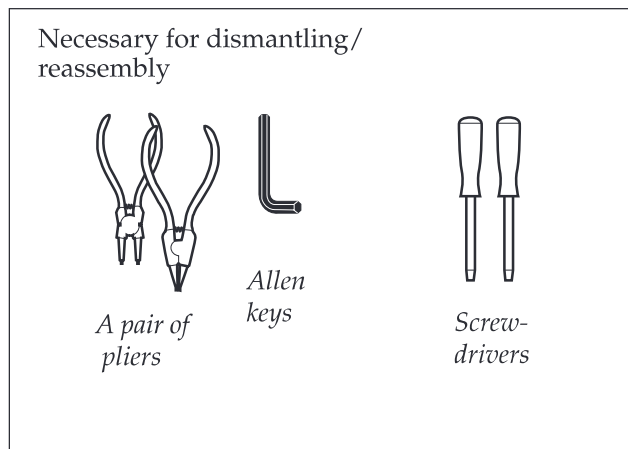

All O-rings found to be hard or damaged shall be replaced.

Fig. 6

## GAD spring 615 – Assembly drawings

T008	T040	T075	T100
1 Valve spring	26 Washers	25 Washers	32 Washers
<p>213</p> <p>612C</p> <p>623</p> <p>615</p>	<p>213</p> <p>612C</p> <p>615</p>	<p>213</p> <p>612C</p> <p>615</p>	<p>213</p> <p>612C</p> <p>615</p>
	<p>Washer positions</p>		<p>Washer positions</p>
Range: 2-8 bar	Range: 6-40 bar	Range: 15-75 bar	Range: 30-100 bar

Fig. 7

# Dismantling, replacement of components and reassembly, GAR/GAS

**A.**

- Remove the valve from the system. Use appropriate vessels to collect oil spillage when removing and opening the valve.

Fig. 9

**B.**

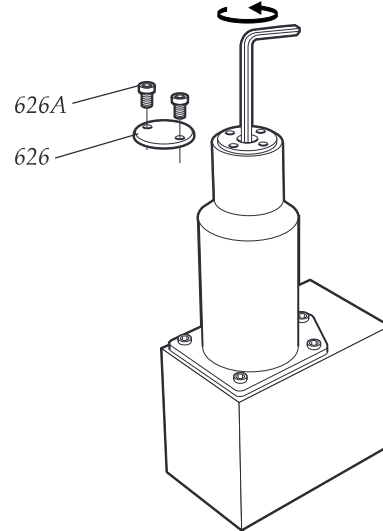

- Loosen the cap screws 626A and remove the cap 626.
- Turn the set screw 608 CCW to ease the spring tension.

Fig. 11

**C.**

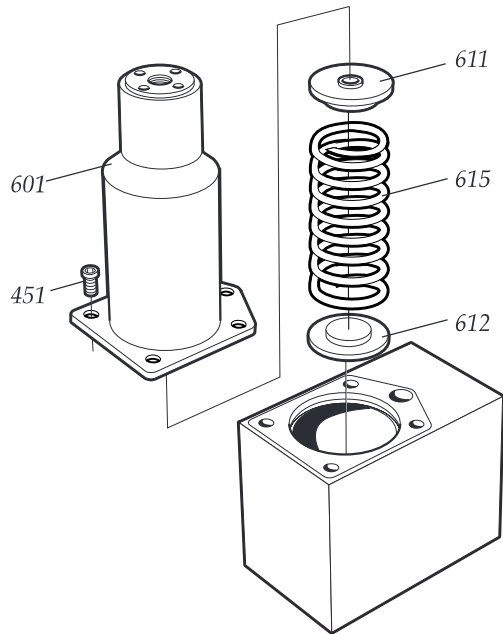

- Loosen screws 451. Remove valve cover 601 and collect the washers 611 and 612 and the valve spring 615.

Fig. 10

**D.**

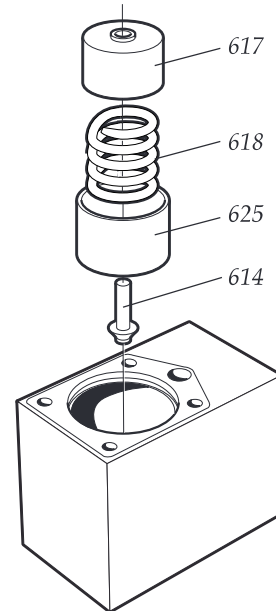

- Carefully pull out the compensator piston 617, auxiliary spring 618, compensator sleeve 625 and poppet 614.

Fig. 12



### E.

- Replace the springs if necessary.
- Check the outer surface on the compensator piston 617 and the inner surface on the compensator sleeve 625. If you find wear or corrosion, replace these parts.
- Check the poppet 614. Replace it if damaged.

Fig. 13

### F.

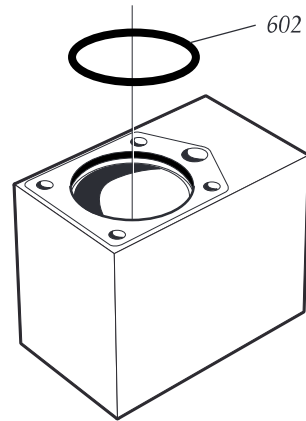

- Replace the O-ring 602.
- Grease the new O-ring before mounting it.

Fig. 14

### G.

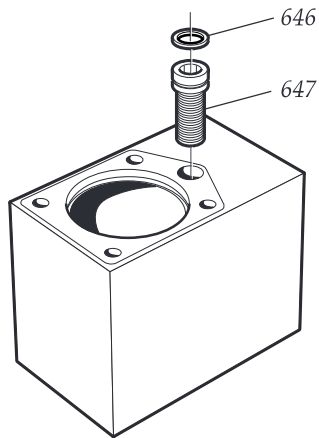

- Loosen and remove the throttle screw 647 and replace the O-ring 646 if hardened or damaged. Fit the throttle screw back into place.
- Grease the new o-ring before mounting it.

Fig. 15

### H.

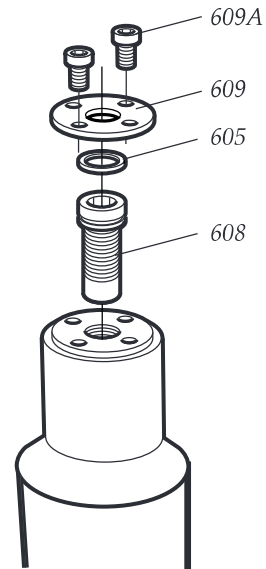

- Unscrew the screws 609A and remove the nut 609.
- Unscrew the set screw 608 and replace the O-ring 605. Fit the set screw 608 back into place again.
- Grease the new O-ring before mounting it.

Fig. 16

### I.

- Reassemble in reversed order. Put the valve back into the system.
- Readjust the pressure and start-up according to the instructions under "Start-up".

Fig. 17

# Dismantling, replacement of components and reassembly, GAD

## A.

- Remove the valve from the system. Use appropriate vessels to collect oil spillage when removing and opening the valve.

Fig. 18

## B.

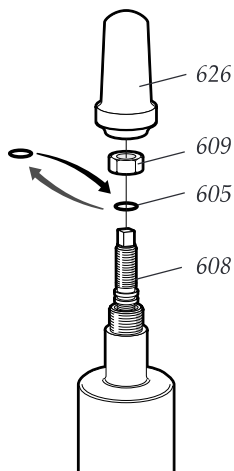

- Remove the cap 626 and the nut 609 and unscrew the set screw 608 a few turns until you see the O-ring 605. Replace the O-ring if necessary.

Fig. 19

## C.

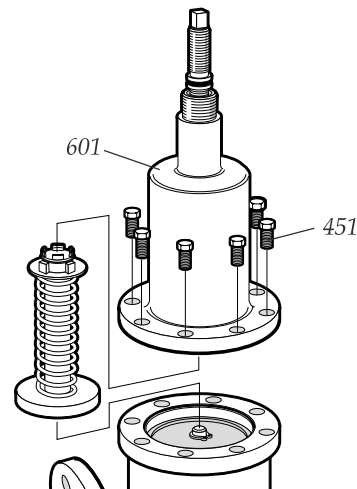

- Loosen and remove the screws 451. Remove the valve cover 601 and collect the valve assembly.

Fig. 20

## Spring size change, D+E

### D.

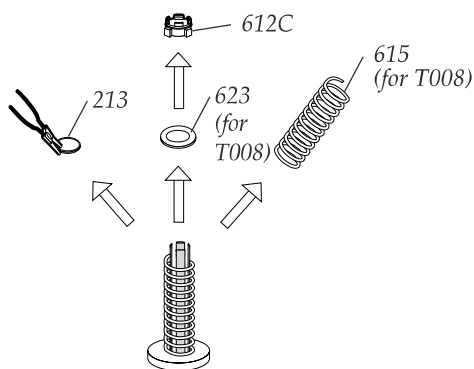

If you need another pressure range:

- Remove the retaining ring 213 with a pair of pliers.
- Remove the spring washer 612C and the stop washer 623 (for T008).
- Remove the spring 615.

Fig. 21

### E.

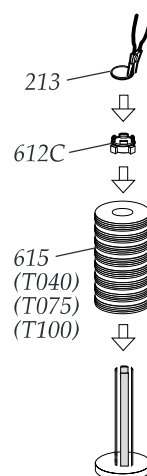

- Mount the washers according to fig. 7 at page 7 or the T008 spring.
- Mount (the washer 623 if you mount the T008) the spring washer 612C and the retaining ring 213.

Fig. 22

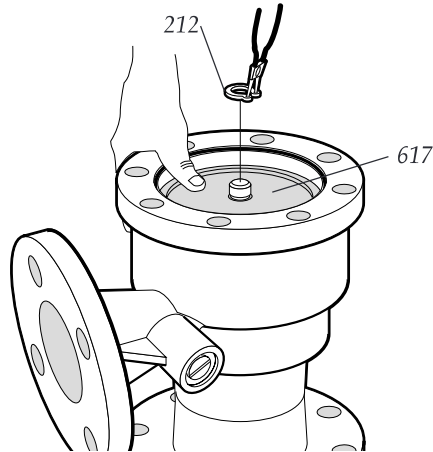
**F.**

- Carefully remove the retaining ring 212 with a pair of pliers while keeping the compensator piston 617 on place with the other hand\*.

Fig. 23

\* Use a press as a help for T040, T075, T100

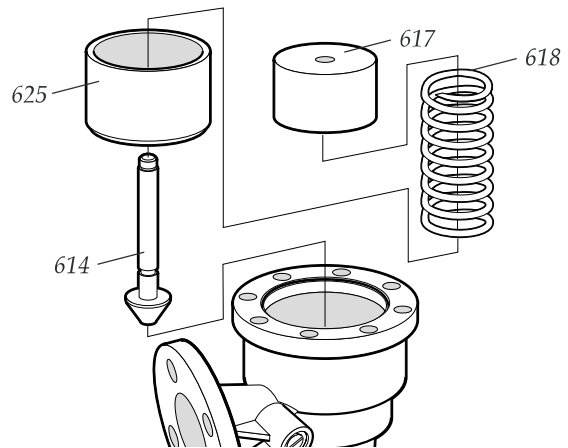
**G.**

- Carefully pull out the compensator piston 617, auxiliary spring 618, compensator sleeve 625 and poppet 614.

Fig. 24

**H.**

- Replace the spring if necessary. Check the outer surface on the compensator sleeve. If you find wear or corrosion, replace these parts. Check the poppet 614, especially the groove for the retaining ring 212. Replace it if damaged.

Fig. 25

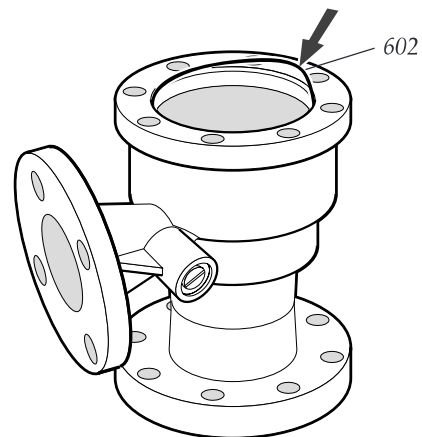
**I.**

- Replace the O-ring 602 if necessary. Lubricate the new O-ring before mounting it.

Fig. 26

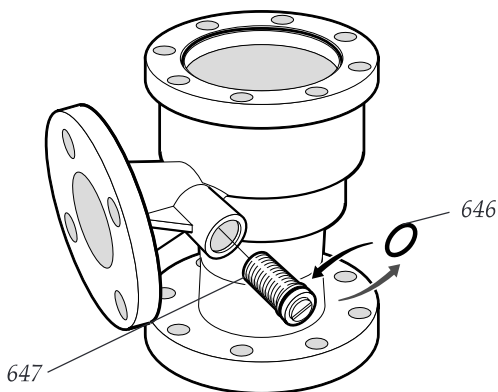
**J.**

- Note the position of the throttle screw 647. Loosen and remove it and replace the O-ring 646 if hardened or damaged. Lubricate the new O-ring before mounting it. Fit the throttle screw back into place.

Fig. 27

**K.**

- Reassemble in reverse order. Lubricate parts 614, 625 and 617 before reassembly.
- Put back the valve into the system. Readjust the pressure and proceed according to instructions under "Start-up".

Fig. 28



A Member of the  
COLFAX PUMP GROUP

**[www.imo.se](http://www.imo.se)**