

EMTEC Series



A Colfax Business Unit

3 Screw Pumps

Emtec-A Performance @ 1.0cSt

1750 RPM															
Pressure (psig)		100	200	300	400	500	600	700	800	900	1000	1100	1200	1300	1400
20R38	GPM	3.5	3.0	2.5	2.2	1.8	1.5	1.3	1.0						
	BHP	0.5	0.8	1.1	1.4	1.7	2.0	2.3	2.5						
20R46	GPM	4.9	4.2	3.7	3.3	2.9	2.6	2.3	2.0	1.8	1.5	1.3			
	BHP	0.6	1.0	1.4	1.8	2.1	2.5	2.9	3.3	3.6	4.0	4.4			
20R56	GPM	6.4	5.3	4.4	3.7	3.1	2.5	2.0							
	BHP	0.8	1.3	1.8	2.4	2.9	3.4	3.9							
40R38	GPM	7.8	6.8	6.1	5.5	4.9	4.4	4.0	3.6	3.2	2.8	2.4	2.1		
	BHP	0.9	1.5	2.1	2.7	3.3	3.9	4.5	5.1	5.7	6.3	6.9	7.4		
40R46	GPM	10.5	9.3	8.3	7.5	6.8	6.2	5.6	5.1	4.6	4.1	3.6	3.2	2.7	
	BHP	1.1	1.9	2.7	3.5	4.3	5.0	5.9	6.6	7.4	8.2	9.0	9.8	10.6	
80R36	GPM	14.9	13.5	12.3	11.4	10.5	9.7	9.0	8.4	7.8	7.2	6.6	6.1	5.6	5.1
	BHP	1.5	2.6	3.7	4.8	5.9	6.9	8.0	9.1	10.2	11.3	12.4	13.5	14.5	15.6
80R46	GPM	21.7	19.7	18.2	16.9	15.7	14.7	13.8	12.9	12.1	11.3	10.6	9.9	9.2	8.5
	BHP	2.0	3.6	5.1	6.7	8.2	9.8	11.3	12.8	14.4	15.9	17.5	19.0	20.6	22.1
140R39	GPM	29.2	27.1	25.6	24.2	23.1	22.0	21.1	20.2	19.3	18.5	17.8	17.0	16.3	15.7
	BHP	2.7	4.7	6.7	8.7	10.7	12.7	14.6	16.6	18.6	20.6	22.6	24.6	26.6	28.6
140R46	GPM	37.9	35.2	33.2	31.4	29.9	28.5	27.2	26.1	25.0	23.9	22.9	22.0	21.1	20.2
	BHP	3.3	5.9	8.5	11.1	13.7	16.3	18.8	21.4	24.0	26.6	29.2	31.8	34.4	37.0
210R40	GPM	47.4	44.7	42.7	40.9	39.4	38.0	36.8	35.6	34.5	33.4	32.5	31.5	30.6	29.7
	BHP	4.3	7.5	10.6	13.8	16.9	20.1	23.2	26.4	29.5	32.6	35.8	38.9	42.1	45.2
210R46	GPM	59.2	55.8	53.1	50.8	48.9	47.1	45.4	43.9	42.4	41.1	39.8	38.6	37.4	36.2
	BHP	5.2	9.1	13.0	17.0	20.9	24.9	28.8	32.8	36.7	40.7	44.6	48.6	52.5	56.5
280R43	GPM	69.1	65.0	61.8	59.1	56.8	54.7	52.7	50.9	49.2	47.6	46.1	44.6	43.2	41.9
	BHP	6.6	11.2	15.8	20.4	25.0	29.7	34.3	38.9	43.5	48.1	52.7	57.3	61.9	66.5
280R46	GPM	79.5	75.4	72.2	69.6	67.2	65.1	63.2	61.4	59.7	58.1	56.5	55.1	53.7	52.3
	BHP	7.2	12.4	17.6	22.9	28.1	33.3	38.5	43.7	49.0	54.2	59.4	64.6	69.8	75.1
440R40	GPM	101.3	97.1	93.8	91.1	88.6	86.4	84.4	82.5	80.8	79.1	77.5	76.0	74.6	73.2
	BHP	9.6	16.1	22.6	29.1	35.6	42.1	48.6	55.1	61.7	68.2	74.7	81.2	87.7	94.2
440R46	GPM	128.7	123.1	118.9	115.3	112.1	109.3	106.6	104.2	101.9	99.7	97.6	95.7	93.8	92.0
	BHP	11.3	19.6	27.9	36.2	44.5	52.8	61.1	69.3	77.6	85.9	94.2	102.5	110.8	119.1

3500 RPM															
Pressure (psig)		100	200	300	400	500	600	700	800	900	1000	1100	1200	1300	1400
20R38	GPM	8.4	7.9	7.4	7.1	6.7	6.5	6.2	5.9	5.7	5.5	5.3	5.1	4.9	4.7
	BHP	1.5	2.0	2.6	3.2	3.8	4.3	4.9	5.5	6.1	6.6	7.2	7.8	8.4	8.9
20R46	GPM	11.3	10.7	10.2	9.8	9.4	9.1	8.8	8.5	8.2	8.0	7.7	7.5	7.3	7.2
	BHP	1.6	2.4	3.1	3.9	4.7	5.4	6.2	6.9	7.7	8.4	9.2	9.9	10.7	11.5
20R56	GPM	15.4	14.3	13.5	12.8	12.1	11.6	11.1							
	BHP	2.0	3.0	4.1	5.1	6.2	7.2	8.3							
40R38	GPM	18.0	17.0	16.3	15.7	15.1	14.6	14.2	13.7	13.3	13.0	12.6	12.3	11.9	11.6
	BHP	2.3	3.5	4.7	5.9	7.1	8.3	9.4	10.6	11.8	13.0	14.2	15.4	16.6	17.8
40R46	GPM	24.1	22.9	21.9	21.1	20.4	19.8	19.2	18.6	18.1	17.6	17.2	16.7	16.3	15.9
	BHP	2.7	4.3	5.9	7.5	9.0	10.6	12.2	13.8	15.4	17.0	18.5	20.1	21.7	23.3
80R36	GPM	33.5	32.0	30.9	29.9	29.1	28.3	27.6	26.9	26.3	25.8	25.2	24.7	24.2	23.7
	BHP	3.9	6.1	8.2	10.4	12.6	14.7	16.9	19.1	21.2	23.4	25.6	27.7	29.9	32.1
80R46	GPM	48.2	46.2	44.7	43.4	42.3	41.2	40.3	39.4	38.6	37.8	37.1	36.4	35.7	35.0
	BHP	4.8	7.9	11.0	14.1	17.2	20.3	23.4	26.5	29.6	32.7	35.8	38.9	42.0	45.1
140R39	GPM	66.3	61.2	59.7	58.3	57.2	56.1	55.2	54.3	53.4	52.6	51.9	51.1	50.5	49.8
	BHP	6.7	10.7	14.7	18.7	22.7	26.6	30.6	34.6	38.6	42.6	46.5	50.5	54.5	58.5
140R46	GPM	82.3	79.6	77.5	75.8	74.3	72.9	71.6	70.5	69.3	68.3	67.3	66.3	65.4	64.6
	BHP	7.9	13.1	18.3	23.5	28.7	33.8	39.0	44.2	49.4	54.6	59.7	64.9	70.1	75.3
210R40	GPM	101.3	98.6	96.5	94.8	93.3	91.9	90.7	89.5	88.4	87.3	86.3	85.4	84.5	83.6
	BHP	11.0	17.3	23.6	29.9	36.2	42.4	48.7	55.0	61.3	67.6	73.9	80.2	86.4	92.7
210R46	GPM	126.9	123.4	120.7	118.5	116.5	114.7	113.1	111.6	110.1	108.7	107.5	106.2	105.0	103.9
	BHP	12.6	20.5	28.4	36.3	44.2	52.1	60.0	67.9	75.8	83.7	91.6	99.5	107.3	115.2
280R43	GPM	148.1	144.0	140.8	138.2	135.8	133.7	131.8	130.0	128.3	126.7	125.1	123.7	122.3	120.9
	BHP	17.1	26.3	35.5	44.7	53.9	63.2	72.4	81.6	90.8	100.0	109.3	118.5	127.7	136.9
280R46	GPM	169.0	164.9	161.7	159.1	156.8	154.6	152.7	150.8	149.1	147.5	146.0	144.5	143.1	141.8
	BHP	18.3	28.7	39.2	49.6	60.0	70.5	80.9	91.4	101.8	112.2	122.7	133.1	143.5	153.9
440R40	GPM	213.0	208.7	205.4	202.7	200.3	198.1	196.0	194.2	192.4	190.7	189.2	187.6	186.2	184.8
	BHP	25.1	38.1	51.1	64.2	77.2	90.2	103.2	116.3	129.3	142.3	155.3	168.4	181.4	194.4
440R46	GPM	270.7	265.2	260.9	257.3	254.2	251.2	248.7	246.3	244.0	241.8	239.7	237.7	235.9	234.0
	BHP	28.6	45.2	61.8	78.4	94.9	111.5	128.1	144.7	161.2	177.8	194.4	211.0	227.6	244.0

Max pressure is 1450psig
Performance is based on Hydraulic Institute standards

Emtec: Advanced Technology for Long Service Life

Emtec pumps are specifically designed to withstand the harsh environment of high pressure machine tool coolant service. Special hardening techniques produce a surface hardness similar to ceramic in the housing bores while maintaining elasticity that eliminates the danger of bore surface fracture. The hardening process of the rotor set includes PVD* treatment that results in a surface hardness of 1200HV. The Emtec pump is fully hydrodynamically balanced which eliminates thrust loads due to differential pressure. The power

rotor's balance piston is extra long which improves the pump's volumetric efficiency. Flow that crosses the balance piston serves to cool and lubricate the silicon carbide mechanical shaft seal faces. In applications where the "DQ" version is utilized, the shaft seal is eliminated to further reduce cost. Flow that passes across the balance piston is vented from the pump and into the reservoir. In this design, a labyrinth ring on the fluid side of the ball bearing prevents coolant "splash" from washing out the bearing grease.

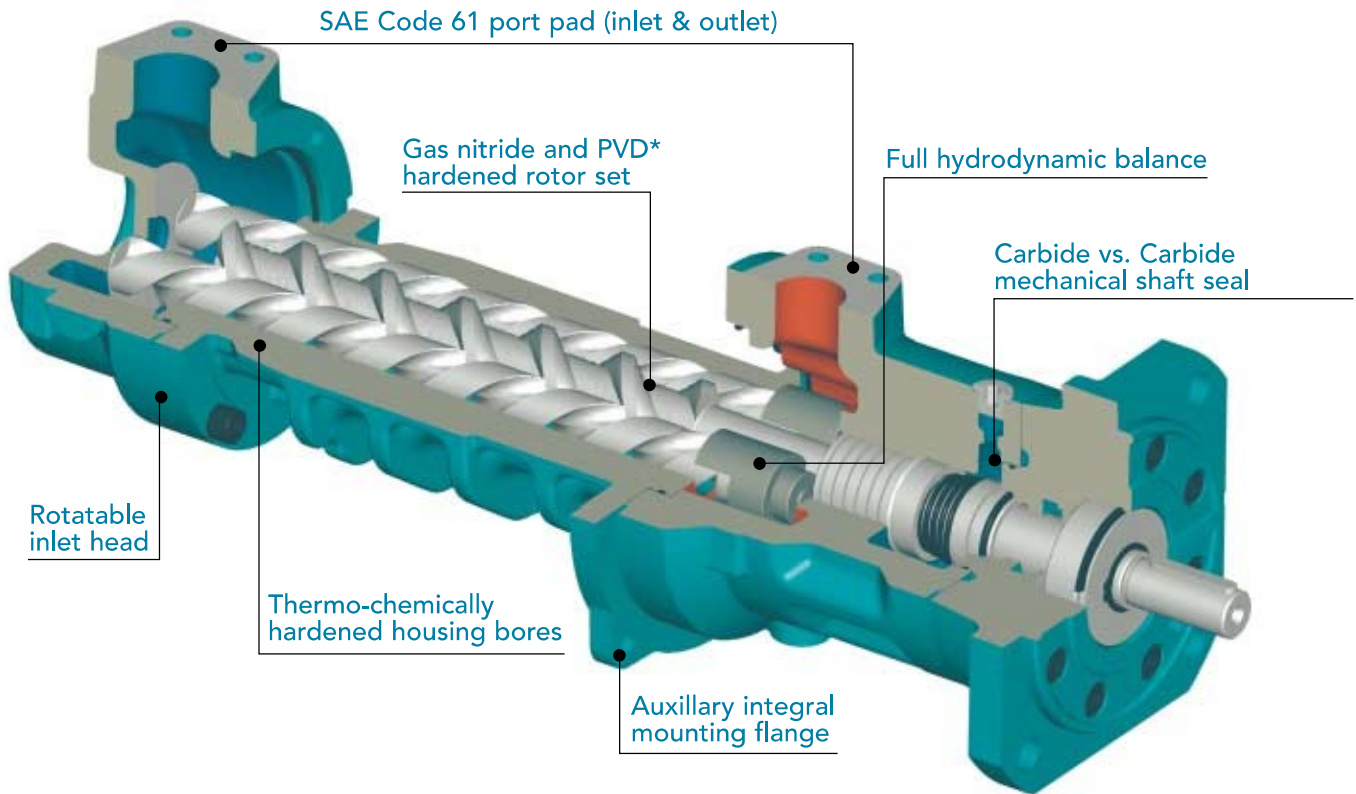

* Physical vapor depositon

Emt-A 20 thru 210 pumps are offered in either "D8.6" or "DQ" design.



The "DQ" variant has all the features and benefits of the "D8.6" variant.

However, in place of the mechanical shaft seal, a shaft sealing ring is utilized and an axial inlet head is provided.

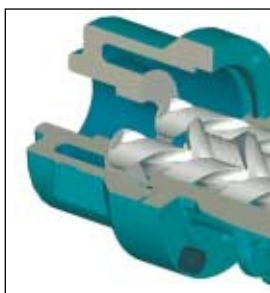

Materials

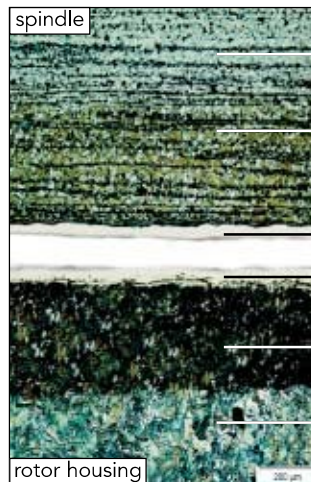

Rotor Set

- Base material: Alloy steel
- Gas nitride hardened zone (62 HRC)
- PVD hard coating: (1200 HV)

Housing

- Ceramic-like bore surface (1200 HV)
- Hardened transition zone (62 HRC)
- Base material: Cast Iron

The special material combination used for Emtec brings together the highest possible hardness with optimal elasticity and resistance to fracture.

Emtec: Extremely Variable in Installation

For foot mounted, dry installations (easily accessible for maintenance), a silicon carbide mechanical shaft seal assures a long service life.



Emtec's unique center mounting flange allows for easy and economical tank-top installation with the discharge connection above the tank top.

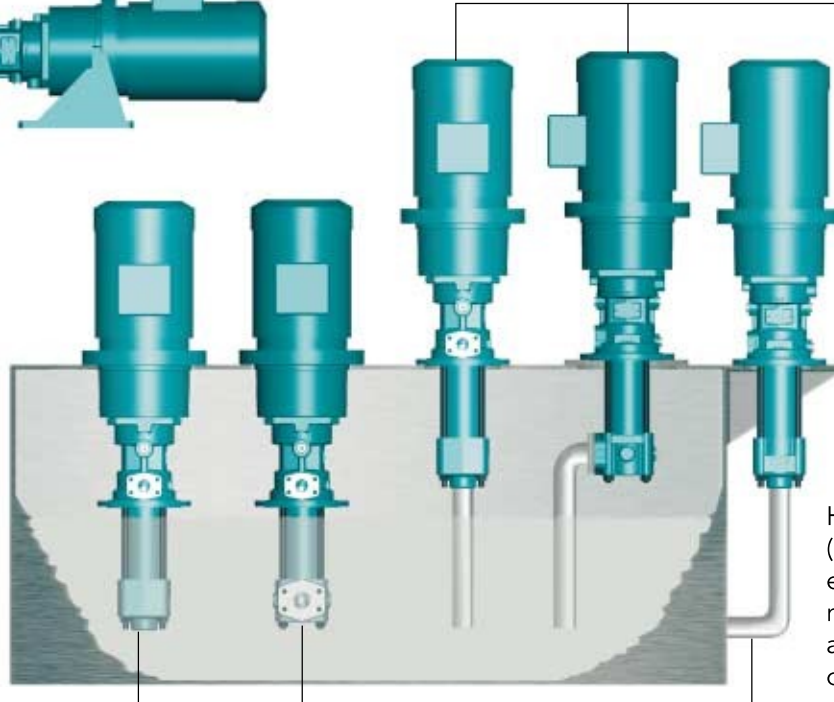

Submerged tank mounting saves space, maintenance and costs compared with dry mount installation.

Horizontal or vertical (shaft up) "on-tank" eliminates the requirement for additional space on the pump skid.

Materials of Construction

Rotor Housing: Cast Iron—basic hardness (62 HRC)
1200 HV surface hardness

Inlet Head: Cast Iron

Discharge Casing: Cast Iron

Power & Idler Rotors: Alloy Steel
Gas Nitrided (62 HRC)

PVD Hard Coat (1200 HV)

Mounting Flange: Cast Iron

Mechanical Seal: Silicon carbide, fluorocarbon elastomer

Elastomer: Fluorocarbon

Emtec Performance Parameters

Capacity: 3 to 265 usgpm

Temperature Range: to 176°F

Max Inlet Pressure: 145 psig

Differential Pressure: 1450 psig (emulsion)
1740 psig (oil)

Max Outlet Pressure: to 1885 psig

Viscosity Range: 1 to 2000 cSt

Maximum allowable air entrainment

Emulsions & Solutions: 10%

Oils: 7%

Model Nomenclature

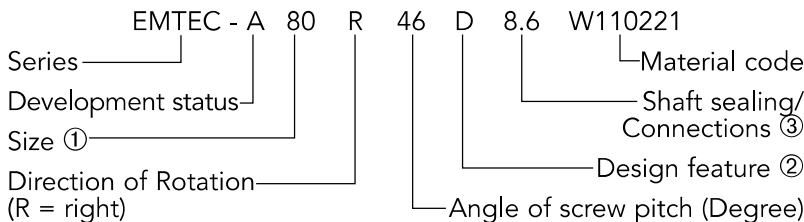

① theor. capacity at 1450 1/min and 46 degree angle of screw pitch

② D = external ball bearing

③ Shaft seal/Connections

Abbreviation	Type
Q	Shaft seal ring/axial inlet, pipe thread (radial inlet, SAE optional)
8.6	Mechanical seal/radial inlet, SAE

Typical Sound Levels

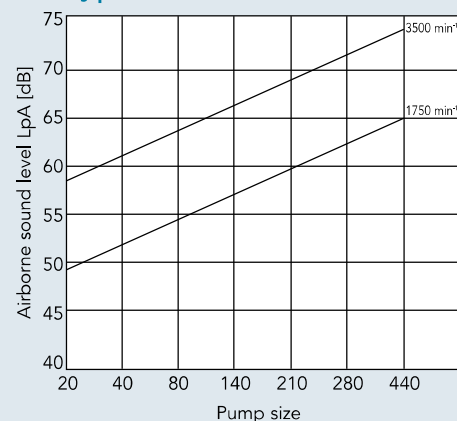

Emtec-A Typical Dimensions

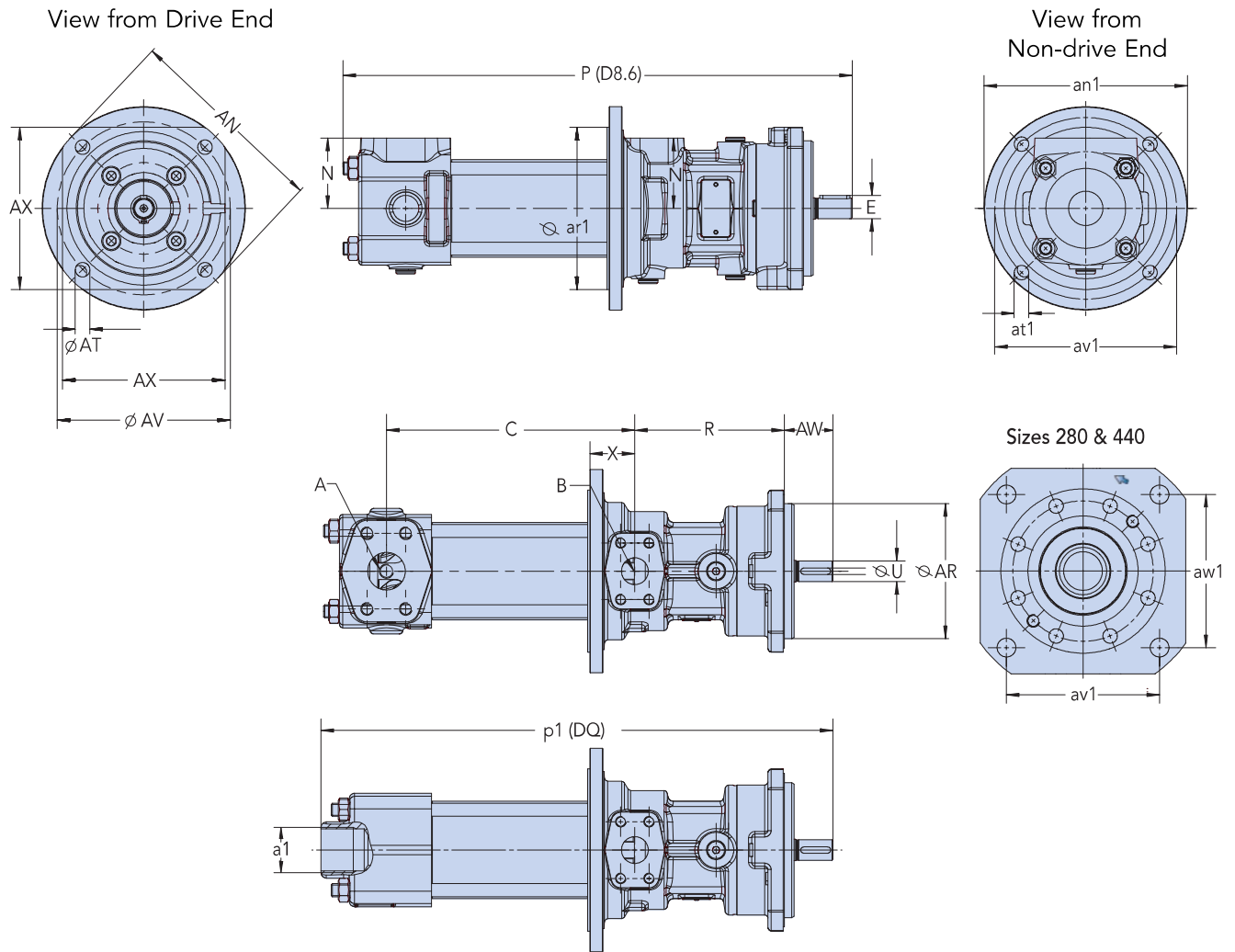

Pump Size	Porting			Mounting Flange					Shaft			Pump Body										weight (lbs.)	
	A	a1	B	AN	AR	AT	AV	AX	E	U	AW	an1	ar1	at1	av1	aw1	C	N	P	p1	R		X
Emt-A 20	1½	1¼	1	7.40	4.92	0.53	6.30	5.91	0.85	0.75	1.77	7.40	5.91	0.53	6.61	N/A	9.04	2.56	18.54	18.54	5.43	1.65	55
Emt-A 40	1½	1¼	1	7.40	4.92	0.53	6.30	5.91	0.85	0.75	1.77	7.40	5.91	0.53	6.61	N/A	10.75	2.56	20.59	20.51	5.91	1.65	66
Emt-A 80	2	2	1½	9.92	4.92	0.53	6.30	5.91	0.85	0.75	2.01	8.66	7.87	0.53	8.90	N/A	12.99	3.74	23.19	23.58	6.26	2.2	110
Emt-A 140	2	2	1½	9.92	6.30	0.69	7.87	7.48	1.10	0.98	2.87	8.66	7.87	0.53	8.90	N/A	14.88	3.74	26.97	27.76	7.28	2.48	155
Emt-A 210	2½	N/A	2	10.55	6.30	0.69	7.87	7.48	1.22	1.10	2.83	8.85	8.86	*M12	9.61	N/A	17.17	4.53	29.02	N/A	6.85	2.91	210
Emt-A 280	3	N/A	2½	11.50	7.87	0.87	9.84	9.29	1.38	1.26	3.54	9.13	9.13	*M16	7.09	7.48	19.09	4.72	33.90	N/A	8.66	3.31	320
Emt-A 440	4	N/A	3	12.95	7.87	0.87	9.84	9.29	1.61	1.50	3.46	10.43	10.43	*M16	7.87	8.26	21.65	5.31	36.89	N/A	8.43	3.46	465

Notes:

Dimensions are for reference only, not to be used for construction. Outline drawing suitable for construction is available upon request. Dimensions shown are in inches unless otherwise indicated.

A & B are SAE code 61

a1 is BSW thread form

*Drilled and tapped for metric bolting. Metric bolt size shown.



20 DQ



140 D8.6



A Colfax Business Unit

Imo Pump
PO Box 5020 (28111-5020)
1710 Airport Road (28110)
Monroe, NC USA

Phone 704-289-6511
Fax 704-289-9273
E-mail: imo.pump@colfaxcorp.com
Internet: www.imopump.com

EMTEC-06
© 2006 Imo Pump All rights reserved



Manufacturing under ISO 9001:2000 Quality Management Systems