

List of components

Valid for all pumps in sizes: ALG 080, 090, 100 & 110; Rotor diameter and generation: B3/N3

With version codes: N } V } B } I }

The version code is composed of the letters in the 4 columns.

C }

Also valid for pump options: A021

J }

Example of pump designations

std: ALG 080N3 NVBI; option ALG 110N3 NVCI A021

Pos No	Denomination	Qty	Mounting form		Spare parts sets:					
			xxBx	xxJx	G012	G020	G050	G053	G054	G057
1020	Power rotor CW-rot.	1			x				x	x
103	Ball	1			x				x	x
104	Spring	1			x				x	x
105	Hole screw	1			x				x	x
106	Balancing piston	1			x				x	x
113	Key	1			x				x	x
120	Distance sleeve	1							x	x
122	Ball bearing	1							x	x
123	Locking washer	1							x	x
124	Bearing nut	1							x	x
130	Washer	1							x	x
130A	Stop screw	4							x	x
139	Sealing washer	1					x	x	x	x
140	O-ring	1					x	x	x	x
2020	Idler rotor	2			x				x	x
209	Tension pin	2			x				x	x
211	Thrust collar	2			x				x	x
301	Sleeve	1				x			x	x
307	Screw	8				x			x	x
307A	Distance sleeve	6				x			x	x
307B	Distance sleeve	2				x			x	x
329	O-ring	1				x		x	x	x
340	Mandrel*	1				x			x	x
354	Bearing bush	1							x	x
355	Screw	2							x	x
355A	Locking plate	2							x	x
382	Screw	4							x	x
382A	Washer	4							x	x
390	Distance tube	4							x	x
391	Bearing plate	1							x	x
401	Pump body	1								
451	Screw	12								
453	Screw	8	x	x						
462	Plug	2	x							
462A	Washer	2	x					x		
463	Plug	1								
463A	Washer	1						x		x
473	Grease nipple	1								
473A	Grease nipple cover	1								
501	Front cover	1								
502	Tension pin incl in 5110	1							x	x
506	Gasket	1							x	
509A	Sealing bush	1				x	x	x	x	x
509B	O-ring	1				x	x	x	x	x
509C	Spring	2				x	x	x	x	x
509D	Washer	1				x	x	x	x	x
5110	Gland	1							x	x
511A	O-ring	1							x	x
527	Sealing cover	1							x	x
537	Plug	1								
537A	Washer	1							x	
551	Inlet chamber	1	x	x						
556	O-ring	1	x	x						

Explanations:

A021: Idler rotors in steel, ALG,APG earlier designation N3E

G065: Inlet chamber

G012: Rotor set

G020: Sleeve element

G050: Shaft seal

G053: Minor kit (G050 + G057)

G054: Major kit = G090

G057: Joint kit

G065: Inlet chamber

G090: Pump element

ALG pumps with H-lead rotor set in size 080-090 are obsolete.

Older generations of pumps

ALG N2E, N2EH, N2ES, N2E/60, N2EH/60, N2ES/60 N3E, N3EH, N3ES. All parts are applicable.

Old designation

Current designation

ALG 80-4 N3E/60
ALG 080N3 NVCI

ALG 90-4B N3EH/60

ALG 090B3 NVBI

ALG 100-4 N3ES/60

ALG 100N3 NVJI

ALG 110-4 N3E

ALG 110N3 NVCI A021

Notes:

* Mounting tool to mount sleeve/pump element into the pump

Ordering code

Pos No	Spare parts (set)	Part numbers for pump size				Note
		080	090	100	110	
G012	Rotor set B-lead	--	088435	--	--	
	" N-lead	--	088427	--	--	
G020	Sleeve element	--	097006	--	--	
G050	Shaft seal	070623	070623	070631	070631	
G053	Minor kit=G050+G057					
G054	Major kit=G090					
G057	Joint kit	186510	186510	186528	186528	
G090	Pump element B-lead	--	096461	--	--	
	" N-lead	--	096453	--	--	
354	Bearing bush	--	047233	--	--	
473	Grease nipple	024372	024372	024372	024372	
511A	O-ring	016931	016931	016964	016964	
556	O-ring	171918	171918	171488	171488	1
	Gasket	021493	021493	021808	021808	1

Assembly drawing

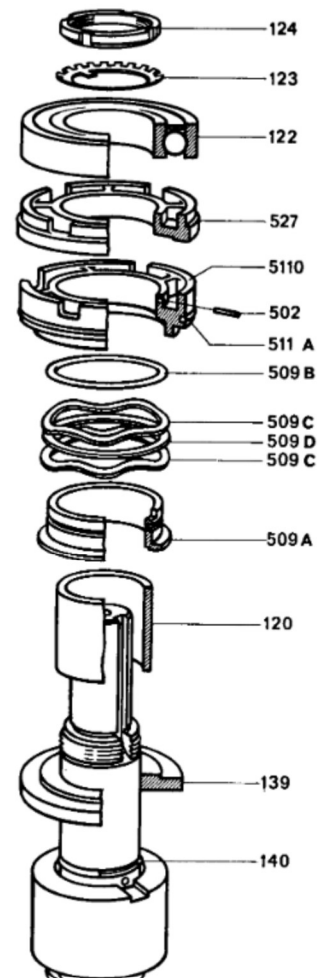

1) From 1987 new pumps are equipped with an O-ring between the pump and inlet chamber. This change was made to avoid leakage. This change was made without changing the pump designation. As spare part to old pumps the old gasket must be used.

