



**Spares available up to end of 2017**

**List of components**

Valid for all pumps in sizes: ACG/UCG 045/052/060/070; Rotor diameter & Generation: K5/N5

With version codes: I } T } B } E } Also valid for pump options: A101, A327

N } V } F } G } Example of pump designations

O } std: ACG 045N5 IVBP; option ACG 070N5 IVBO A101

P }

Pos No	Denomination	Qty	Components included in Spare parts sets:							Note
			G011	G012	G034	G050	G053	G054	G057	
1010	Power rotor CCW-rot	1	x						(x)	
1020	Power rotor CW-rot	1		x					x	
106	Balancing piston	1	x	x					x	6
113	Shaft key	1	x	x					x	
120	Distance sleeve	1								
122	Ball bearing	1					x	x	(x)	9
124	Retaining ring	1					x	x	x	
124A	Support ring	1					x	x	x	
133	Dust protection ring	1					x	x	x	
201	Idler rotor CCW-rot.	2	x						(x)	
202	Idler rotor CW-rot.	2		x					x	
359	Distance washer	1								
359A	Support ring	1					x	x	x	
401	Pump body	1								
424	Sleeve	1								4
424A	Washer	1								4
429	Spindle	1								4
437	O-ring	1								4
451	Screw	4/6								
453	Screw	4								
462	Plug	2								1
462A	Sealing washer	2					x	x	x	1
463	Plug	1								8
463A	Sealing washer	1								8
473	Grease nipple	1								
473A	Grease nipple cover	1								
480	Valve housing	1								2
5010	Front cover	1			x					
502	Tension pin	1								7
502A	Plug	1								7
506	Gasket	1					x	x	x	
509	Shaft seal	1					x	x	x	
514	Retaining ring	1					x	x	x	
520	Cover	1								
520A	Screw	4								
537	Plug	1		x						
537A	Sealing washer	1		x						
540	Steel ball	1		x						5
541	Spring	1		x						5
542	Screw nozzle	1		x						5
545	Tension pin	1								7
551	Rear cover	1								3
556	Gasket	1					x	x	x	
601	Valve cover	1								x
602	Sealing washer	1					x	x	x	x
605	O-ring	1					x	x	x	x
606	Valve housing plug	1								x
607	Sealing washer	1					x	x	x	x
608	Valve spindle	1								x
612	Set screw	1								x
614	Valve piston	1								x
615	Valve spring	1						x		x
621	Set knob	1								x
622	Locking pin	1								x

**Explanations:**

- ACG: Pump with DIN flanges
- UCG: Pump with ANSI flanges
- A101: Nonstandard rotation: CCW (counter clockwise). CW-rotation is standard)
- A327: Pump with Tuning
- G011: Rotor set CCW-rotation option
- G012: Rotor set CW-rotation (std)
- G034: complete front-cover
- G050: Shaft seal
- G053: Minor kit
- G054: Major kit consisting of: G053+G012 (G011)+615
- G057: Joint kit
- G070: Valve element

**Notes:**

- 1) Excluded in xxxG
- 2) Excluded in xxxE
- 3) Valid for xxxE
- 4) Valid for pump option A327
- 5) Valid for generation 5
- 6) Included in item 1020 or 1010
- 7) Included in item 5010
- 8) Items 463 & 463A have been removed from pumps manufactured from summer 1992 and onwards
- 9) A new spare part set G057 excluding ball bearing is introduced. Old set is available during a transition period. Part numbers see

**ACG/UCG (K5/N5) Pumps**  
**Obsolete product - Current ACG (K7/N7) See section C**



Spare parts book  
 September 2016

**Spare parts available up to end of 2017**

**Exploded view**

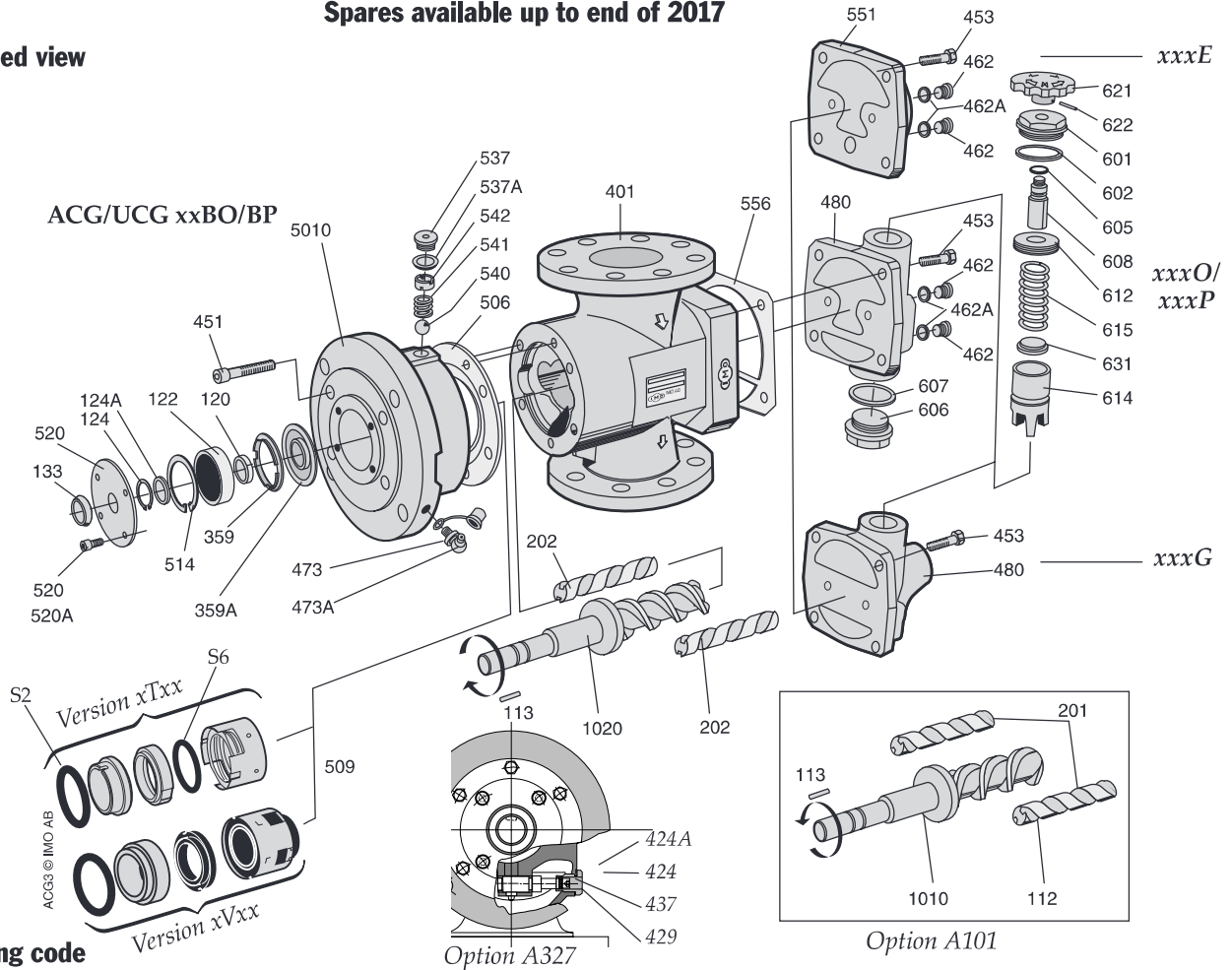

**Ordering code**

Pos No	Spare parts (set)	Part numbers for pump size				
		045	052	060	070	
G011	Rotor set CCW-rot	K-lead	189641	189642	189643	189644
"	"	N-lead	186478	186486	186494	186502
G012	Rotor set CW-rot	K-lead	187542	187559	187567	187575
"	"	N-lead	178913	179507	179515	179523
G034	Front cover	obsolete	obsolete	obsolete	obsolete	obsolete
G050	Shaft seal	xTxx	174094	174102	174110	174128
"	"	xVxx	190335	190336	190338	190340
G053	Minor kit	xTxx	189197	189199	189201	189203
"	"	xVxx	189196	189198	189200	189202
G054	Major kit=G012(G011)+G053+615					
G057	Joint kit incl ball bearing		179531	179549	179556	179564
"	Joint kit excl ball bearing		191422	191423	191424	191425
G070	Valve element	xxxG/xxxP	077933	077933	077941	077941
"	"	xxxO	189622	189622	189645	189645
120	Distance sleeve		173112	172908	173575	173237
122	Ball bearing	Ixxx/Yxxx	173757	017178	155523	017194
"	"	Nxxx	173757	173765	173591	173260
133	Dust protection ring		173138	172981	173609	173278
359	Distance washer		173161	172916	173542	173245
480	Valve housing		obsolete	obsolete	obsolete	obsolete
502	Tension pin		027367	027367	027367	027367
537A	Sealing washer		010975	010975	010975	010975
608	Valve spindle		039743	039743	039743	039743
614	Valve piston		039768	039768	043083	043083
615	Valve spring	xxxG/xxxP	074294	074294	074302	074302
"	"	xxxO	157370	157370	157388	157388
631	Spring seat		039784	039784	043091	043091
S2	O-ring	xTxx	190806	190792	190807	191513

**Recommendation:**

For maintenance the following spare part sets are recommended:

**Set: To be used:**

**G057 Joint kit**

For dismantling of the pump

**G053 Minor kit**

For service

**G054 Major kit**

For repair after damage or greater wear.

Pumps for HFO application should be replaced by our ACG OptiLine, magnetic coupled pump. Pump duty required for correct selection.

**Ordering example:**

For IMO-pump ACG 045N5 IVBP, serial number 457450

Shaft seal  
 pos G050 p/n 190335

Valve spring  
 pos 615 p/n 074294