

LPE4 OptiLine

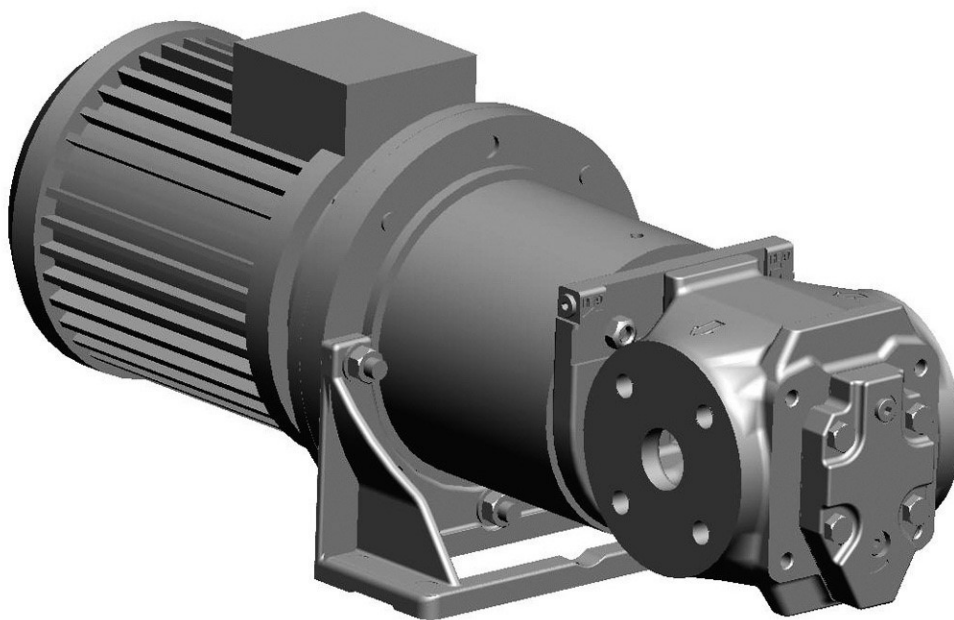

Product Description



Flow volume:	8 - 175 l/min
Max differential pressure:	16 bar
Applications:	Circulation and transfer

1. Applications

1.1 Functionality

The LPE OptiLine pump is used for a number of different fluids:

Fuel oil, vegetable oil, hydraulic oil and other hydraulic fluids, polymers, emulsions and any non-aggressive fluid with sufficient lubricating properties.

1.2 Applications

Typical applications are:

- Circulation for cooling and filtration in large machineries, hydraulic systems and transformer oil for insulation in transformers
- As transfer pumps onboard vessels, in power plants, oil factories, refineries, tank farms etc
- Fuel supply duties for engines
- Supply and circulation of fuel oil

1.3 Installation

The pump is designed to be flange-mounted to its electric motor via a connecting frame and a magnetic coupling. By the angle bracket, the pump may be mounted horizontally or vertically. For vertical installation, a stand mounted on the rear cover can be supplied (version NxYP)

As standard, the pump is delivered excluding counter flanges (DIN type) but can be included if requested.

As standard the pump is delivered with the discharge side to the left when seen from the pump rear end (see below).

For more information about installation, see Service, Maintenance and Startup Instructions for LPE OptiLine generation 4.

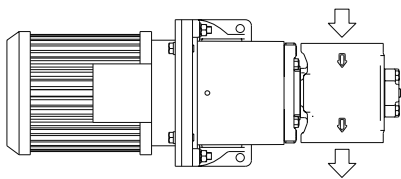

Mounting standard picture M93-0.

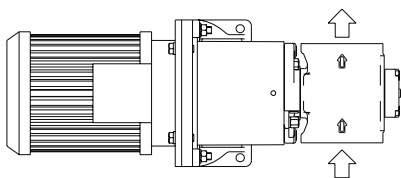

On request the pump can be delivered with opposite flow direction, M39-0.

2. Pump model code

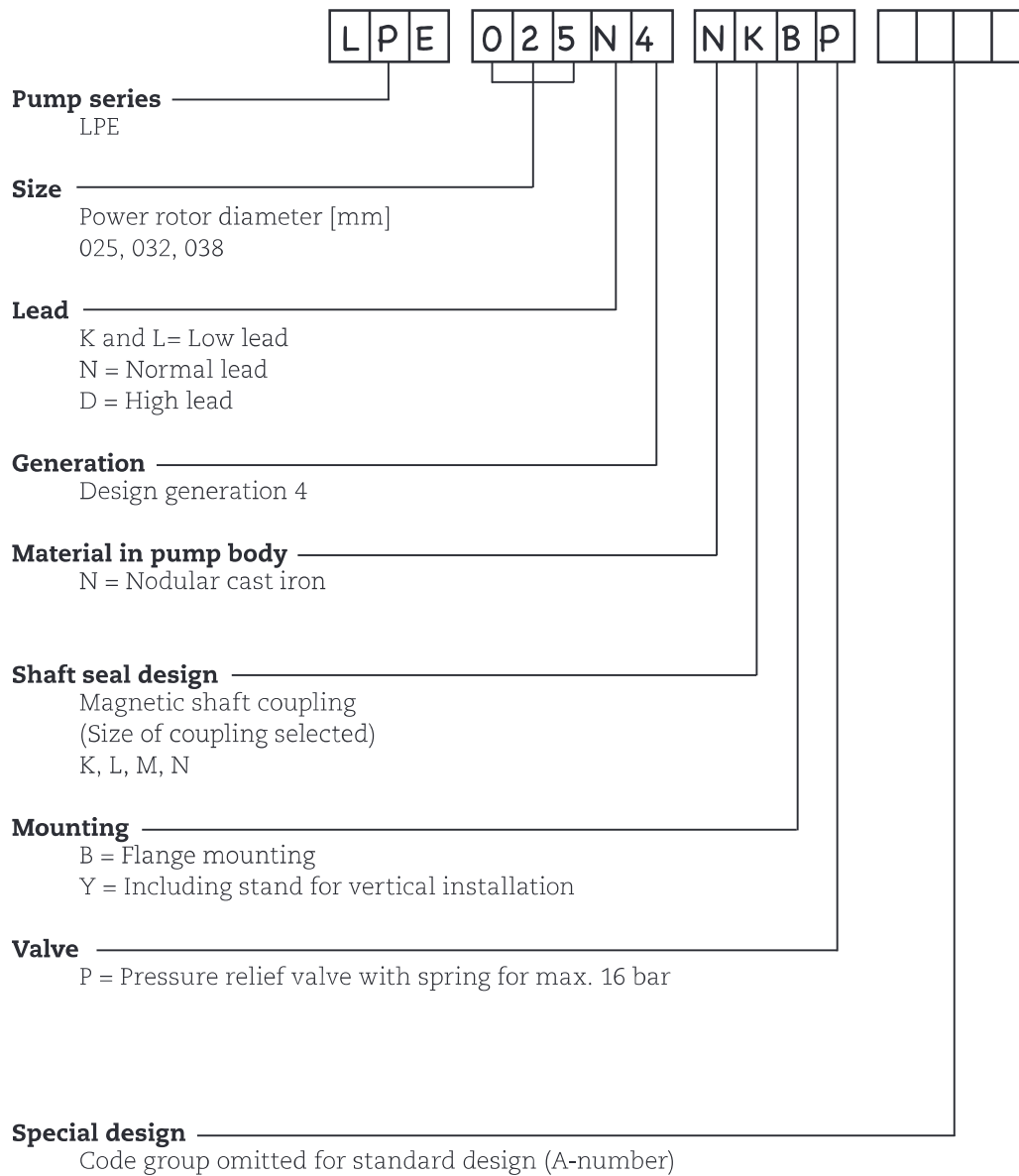

3. Technical Data

3.1 Pressure Information

Pressure relief valve

The pump is equipped with an integral pressure relief valve with internal return, limiting the differential pressure across the pump and protecting the pump. Should the discharge line be blocked, the relief valve will open by the pressure.

The valve is adjustable for different opening pressures. The value of the pressure limit can be set at the factory and should be adjusted at installation (see Service, Maintenance and Installation for LPE OptiLine generation 4).

The maximum pressure accumulation varies with pump size, speed and viscosity, but will normally not exceed 4 bar.

The valve has a maximum set pressure of 16 bar.

Inlet pressure

Minimum inlet pressure (suction capability) is dependent on fluid viscosity and rotation speed. It increases with decreasing viscosity and decreasing speed. Information about minimum inlet pressure for each individual duty case can be obtained from IMO AB or pump selection software WinPump.

Maximum inlet pressure is 7 bar.

Discharge pressure

Maximum discharge pressure is 16 bar.

Differential pressure

Maximum differential pressure is 16 bar but reduced at low viscosities according to table below

Viscosity [cSt]	1,4	2	6	10	20
Max. diff. pressure [bar]	6,9	8	12,4	15	16

Refer to your IMO representative or use the pump selection software WinPump to determine the exact operating limits.

3.2 Driver information

Driver type

The power from motor to the OptiLine LPE pump is transmitted without mechanical contact over a magnetic coupling. A coupling hub with a set of permanent magnets is mounted on the pump shaft. This hub is totally enclosed by a stainless steel can. The motor hub with another set of permanent magnets rotates on the outside of this can. Thus the pumped liquid is totally confined within the pump without the use of a conventional shaft seal.

The pump is designed for this type of drive only.

Speed

The maximum speed is 3600 rpm. For higher speeds, contact IMO AB.

Rotation

The pump is designed to operate in one rotational direction only, as standard clockwise when facing the shaft end. Pumps for CCW rotation can be delivered on special request. For shorter periods of time, a few minutes for emptying a discharge line, the pump may be operated in reverse direction, provided the back pressure is limited to 3 bar.

3. Technical Data

3.3 Sound level

Typical pump sound levels refer to free field conditions at a distance of 1 m from the pump. Noise of driver excluded in the quoted figures. The sound levels are measured at a discharge pressure of 5 bar, speed 2940 rpm and viscosity 40 cSt, according to ISO-3741.

Size	025	032	038
Sound level dB [A]	58	58	58

3.4 Moment of Inertia

Moment of inertia [10^{-6} kgm²]

Coupling / size	025	032	038
K	3692	3715	-
L	5730	5753	5908
M	-	6917	7072
N	-	-	7594

3.5 Magnetic shaft coupling

< Torque values (greater than, at least) [Nm]

	Size		
Coupling	025	032	038
K	7	7	-
L	14	14	14
M	-	22	22
N	-	-	30

3.5 Fluid viscosity

OptiLine pumps:
1,4 – 1500 cSt

For higher viscosity, contact IMO AB.

3.6 Fluid temperature

OptiLine pumps:
-20 – +180 °C

4. Design

4.1 Ball bearing

The pump is fitted with an internal ball bearing which continuously is being greased by the handling media.

4.2 Design material

Model	Material pump	Material rotor	Material idler	Material seal	Material Elastomers
LPE	Nodular cast iron	Steel, surface treated	Cast iron, surface treated	-	Viton

4.3 Steam tracing

During cold start-up conditions, high viscosity could cause the rated torque for the coupling to be exceeded.

The IMO OptiLine pump series have a way to warm up the pump by leading steam into small channels at the front cover. This is recommended if cold upstart can be assumed.

See Pump Unit Dimensions for dimensions of the connections to the steam system.

5. Performance

Typical performance values at 5 bar
Flow calculated at 26 cSt, power at 260 cSt.

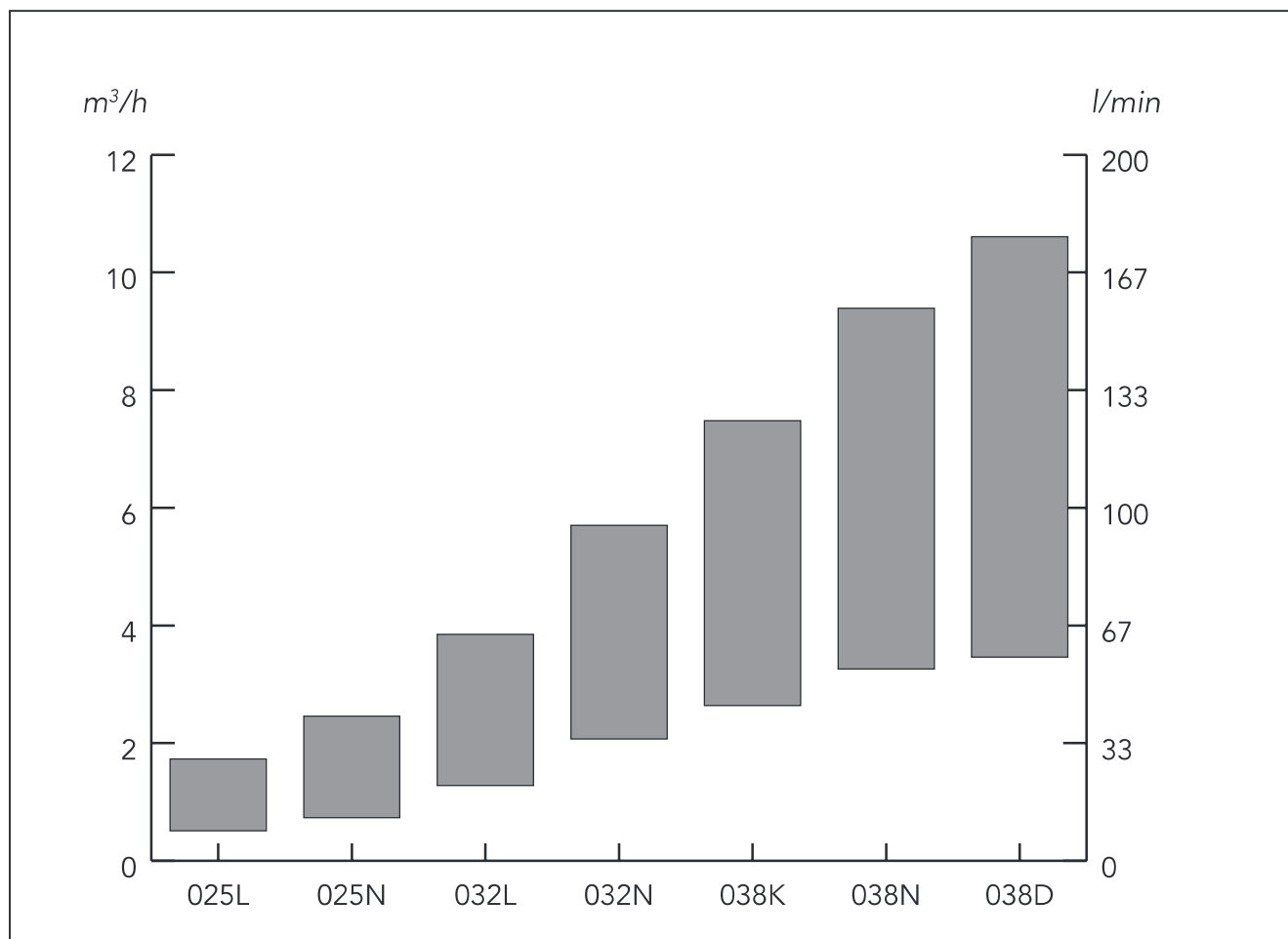

	025L		025N	
rpm	l/min	kW	l/min	kW
1470	8,5	0,3	12,1	0,4
1770	11,5	0,4	16,3	0,5
2950	23,1	0,8	32,7	1,0
3550	28,9	1,1	41,0	1,3

	032L		032N	
rpm	l/min	kW	l/min	kW
1470	21,4	0,5	34,5	0,7
1770	27,5	0,6	43,2	1,0
2950	51,8	1,4	77,5	1,9
3550	64,2	1,9	95,0	2,5

	038K		038N		038D	
rpm	l/min	kW	l/min	kW	l/min	kW
1470	44,0	1,3	54,3	1,2	57,6	1,3
1770	57,1	1,6	69,1	1,5	74,8	1,6
2950	101,5	3,4	127,0	3,2	143,9	3,4
3550	124,7	4,3	156,5	4,1	176,8	4,3

6. Sectional view

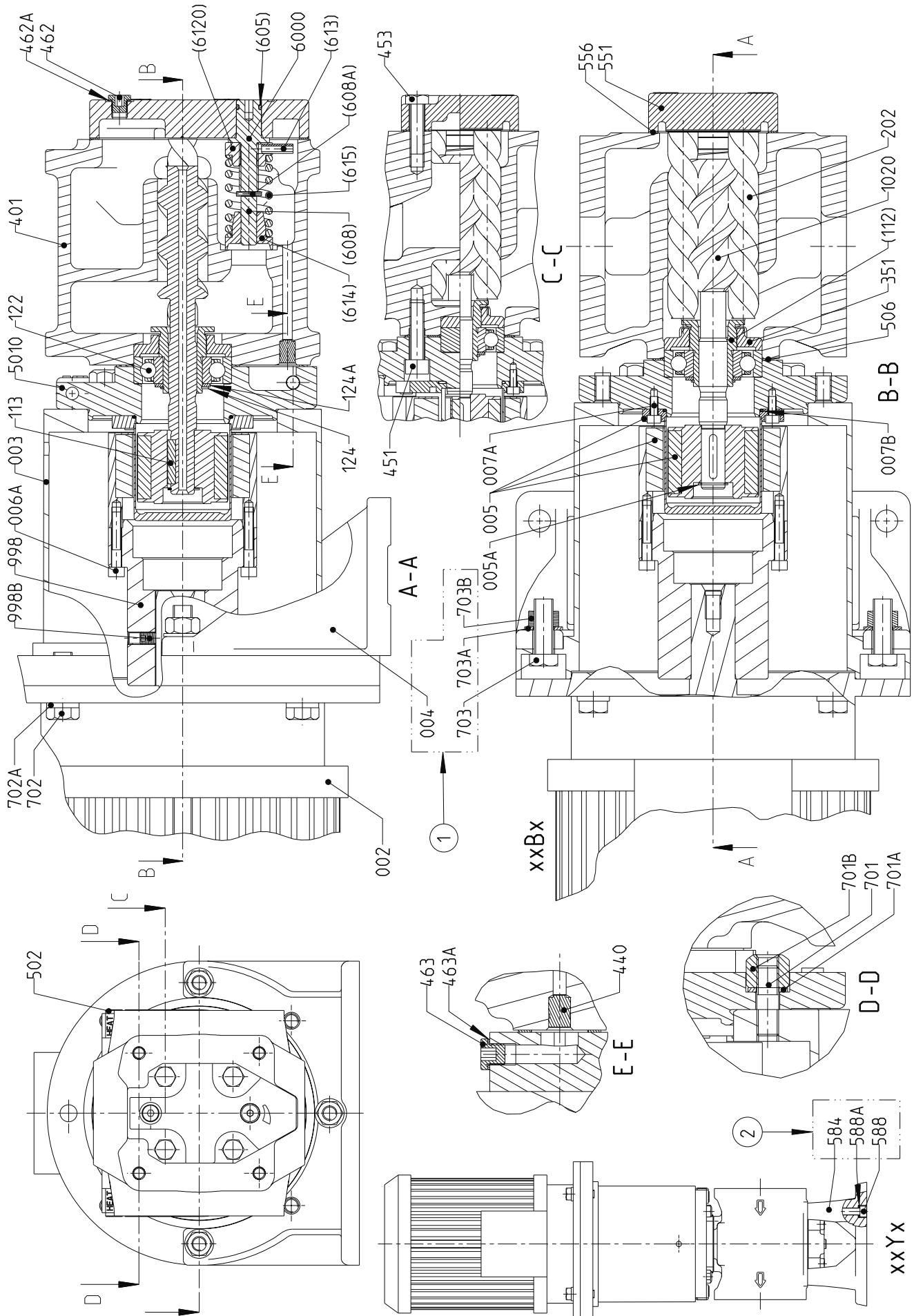

7. List of components

Pos No	Denomination	Pos No	Denomination	Pos No	Denomination
002	Motor	401	Pump body	6000	Complete valve element
003	Connecting frame	440	Expander plug	(605)	O-ring
004	Angle bracket	451	Screw	(608)	Valve spindle
005	Magnetic coupling	453	Screw	(608A)	Tension pin
005A	Retaining ring	462	Plug	(6120)	Complete regulating nut
006A	Screw	462A	Sealing washer	(613)	Pin
007A	Screw	463	Plug	(614)	Valve piston
007B	O-ring	463A	Sealing washer	(615)	Valve spring
1020	Complete power rotor	5010	Front cover	701	Screw
(112)	Balancing piston	502	Plug	701A	Washer
113	Key	506	Gasket	701B	Nut
122	Ball bearing	551	Rear cover	702	Screw
124	Retaining ring	556	Gasket	702A	Washer
124A	Support ring	584	Vertical stand	703	Screw
202	Idler rotor	588	Screw	703A	Washer
351	Balancing bush	588A	Washer	703B	Nut
				998	Drive hub
				998B	Screw

Drawing remarks:

- (1) Applicable for face mounted execution code xxBx
- (2) Applicable for vertical mounted execution code xxYx

Notes:

- Components with Pos No within parenthesis are parts of subassembly

8. Pump dimensions

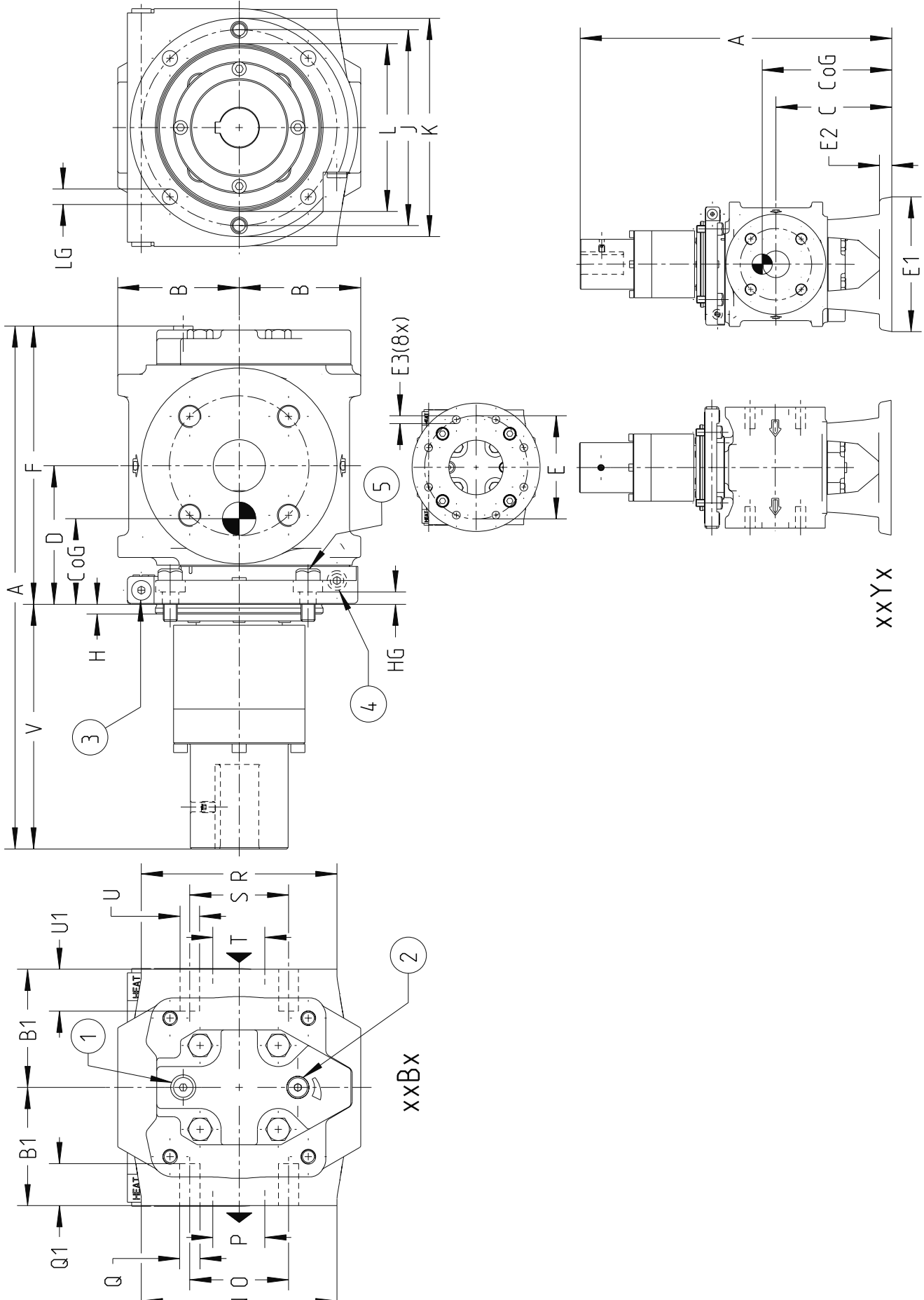

8. Pump dimensions

Pump size	IEC No	Frame size	Main dim.						Foot dim.			Flange dim.					Outlet					Inlet			Weight									
			A	B	B1	C	D	F	V	E	E1	E2	E3	H	HG	J	K	L ¹⁾	LG	N	O	P	Q	Q1	R	S	T	U	U1	CoG	CoG	kg	kg	
025	80	F165	303	366				140																				34	154	19	23			
	90																											32	163					
	100	F215	338	401	81	75	140	86	163		138	190	17	11.5	7	8	140	160	120	11	115	85	25	M12	20			24	166	20	24			
	112									175																								
032	80	F165	339	401				140																				59	170	25	29			
	90																											57	178					
	100	F215	374	436	87	85	162	99	199		152	190	17	11.5	7	8	140	160	120	11	140	100	32	M16	25	140	100	32	M16	25	48	188	26	30
	112									196																								
038	80	F165	346	426				140																				71	193	31	35			
	90																											67	194	32	36			
	100	F215	381	461	89	110	191	95	206		153	190	17	13.5	7	8	140	160	120	11	165	125	50	M16	25	165	125	50	M16	25	59	205	33	37
	112									196																								
xe- ution ode			xxBx	xxYx																								xxBx	xxYx	xxBx	xxYx			

Drawing remarks:

- (1) Inlet gauge. ISO G1/8
- (2) Relief valve. Turn clockwise to increase opening pressure
- (3) Connection for heating. ISO G1/8
- (4) Other side: Outlet gauge. ISO G1/8
- (5) Nut, washer and stud M10 included in delivery for mounting to connecting frame

Notes:

- Dimensions in mm
- Counter flanges according to DIN2633/ND16
- 1) Tolerances ISO h7

9. Pump Unit dimensions

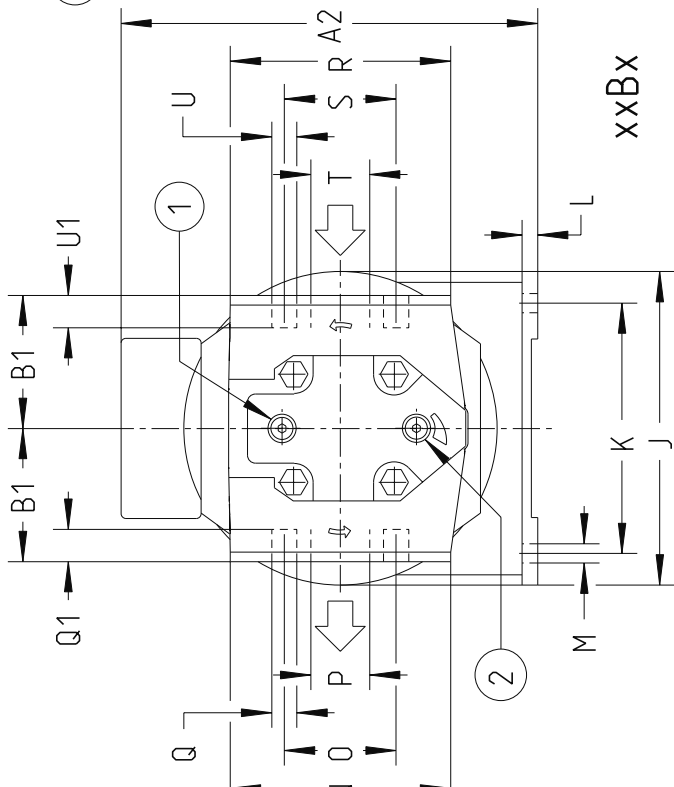
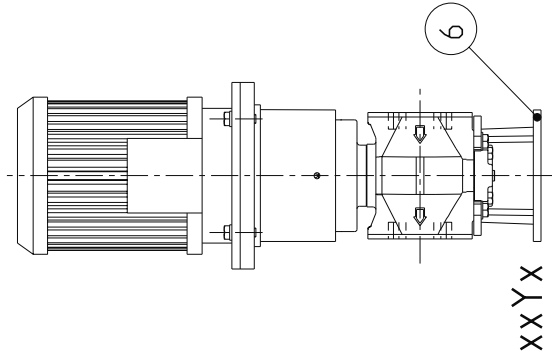
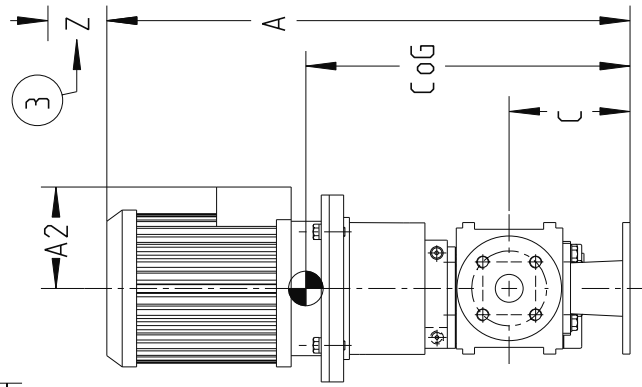
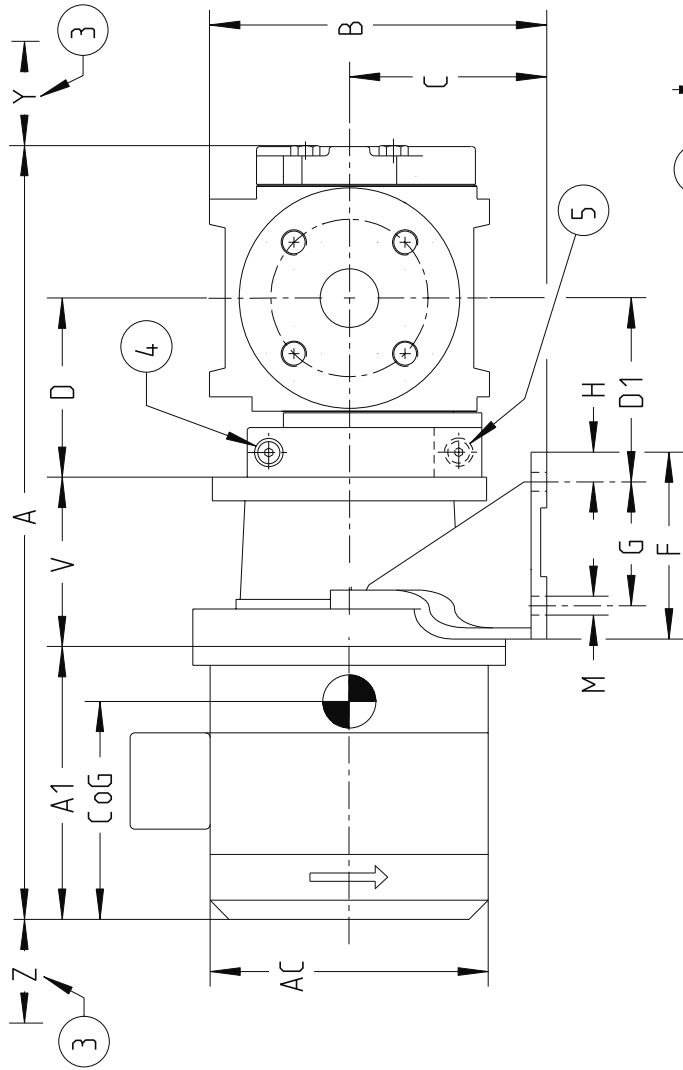

9. Pump Unit Dimensions

Pump size	IEC Frame size	Main dim.										Foot dim.										Outlet						Inlet				Dism.			Weight		
		A	A	A1	A2	A2	AC	B	B1	C	C	D	D1	V	F	G	H	J	K	L	M	N	O	P	Q	Q1	R	S	T	U	U1	Y	Z	Z	Z	CoG	CoG
025	80	553	616	250	249	137	156	193	112	112	146	140	90	15	210	180	12	Ø11															58	133	260	31	34
	90	588	651	285	256	144	176	75	140	86	60			29	250	220	15	Ø14													68	68	297	37	40		
	100	646	709	308	288	156	198	213	132	132	161	175	110	29	250	220	15	Ø14													78	170	321	364	47	51	
	112	673	736	335	306	174	221																								78	170	328	386	53	57	
032	80	589	651	250	249	137	156	199	112	112	159	140	90	15	210	180	12	Ø11													58	133	354	265	37	40	
	90	624	686	285	256	144	176	85	162	99	60			29	250	220	15	Ø14												68	68	355	301	43	46		
	100	682	744	308	288	156	198	219	132	132	174	175	110	29	250	220	15	Ø14												78	191	354	363	54	57		
	112	709	771	335	306	174	221																							78	191	359	386	60	63		
038	80	789	851	394	352	192	258	247	160	160	175	196	120	80	290	260	18														70	100	364	466	80	83	
	90	596	676	250	249	137	156	201	112	112	155	140	90	15	210	180	12	Ø11												58	133	374	275	44	47		
	100	631	711	285	256	144	176	110	191	95	60			29	250	220	15	Ø14											68	68	384	308	49	53			
	112	689	769	308	288	156	198	221	132	132	170	175	110	29	250	220	15	Ø14												78	191	380	365	61	64		
132	716	796	335	306	174	221																							70	100	385	388	67	70			
132	796	876	394	352	192	258	249	160	160	171	196	120	80	290	260	18														70	100	389	468	87	90		
xxBx	xxYx	xxBx	xxYx	xxBx	xxYx	xxBx	xxYx	xxBx	xxYx	xxBx	xxYx	xxBx	xxYx	xxBx	xxYx	xxBx	xxYx	xxBx	xxYx	xxBx	xxYx	xxBx	xxYx	xxBx	xxYx	xxBx	xxYx	xxBx	xxYx	xxBx	xxYx	xxBx	xxYx	xxBx	xxYx	xxBx	xxYx

Drawing remarks:

- (1) Inlet gauge. ISO G1/8
- (2) Relief valve. Turn clockwise to increase opening pressure
- (3) Space for dismantling

Notes:

- Dimensions in mm
- Dimensions A, A1, AC, A2 and weight are approximate values for Busck motors type MS
- Foot VDMA 24 561 PTFL applicable for execution code xxBx

- (4) Connection for heating. ISO G1/8
- (5) Other side: Outlet gauge. ISO G1/8
- (6) For vertical stand dimensions see Pump dimensions page 10

10. Accessories

A bare shaft pump (Fig. 1) can be ordered with the accessories in fig. 2-7.

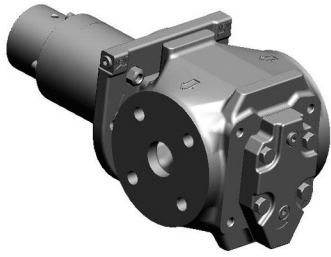

Fig. 1 Bare shaft pump



Fig. Set of counter flanges



Fig. 3 Connecting frame

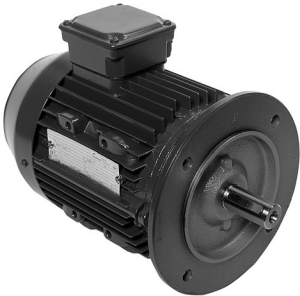

Fig. 4 Electric motor



Fig. 5 Angle Bracket

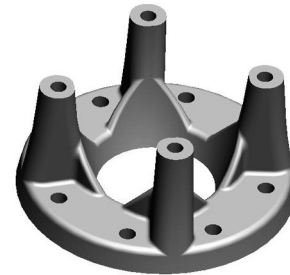

Fig 6. Vertical stand



Fig. 7 Gauge panel

11. Maintenance

Spare parts for these pumps are easily available from stock. For detailed information and know-how about service, see the Service, Maintenance and Startup Instruction for LPE4 Opti-Line pumps or contact IMO AB.

**For latest updates, check:
www.imo.se**