

ACD6 Std Line

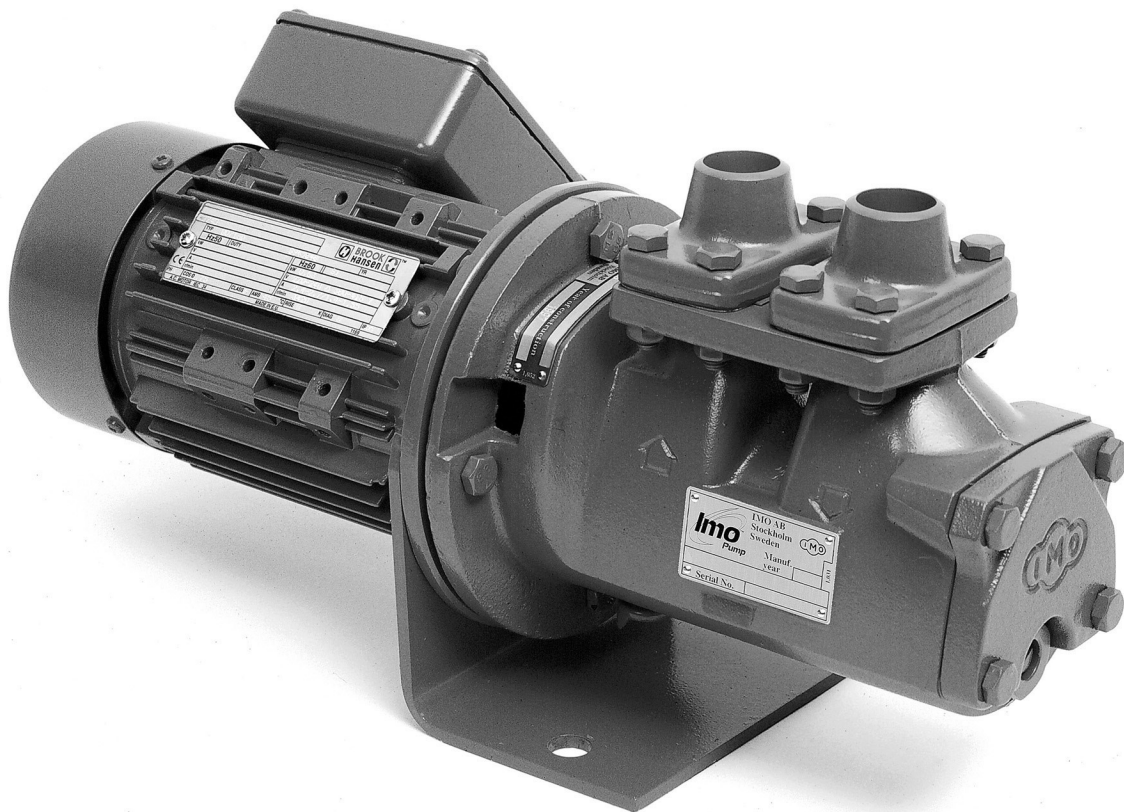

Product Description



Flow volume:	10 - 42 l/min
Max differential pressure:	7 bar
Applications:	Circulation, lubrication and transfer

1. Applications

1.1 Functionality

The ACD pumps come in two executions; Lube Line and Fuel Line. The main difference is the shaft seal design; V-seal - optimized for light duty and T-seal - heavy duty respectively.

The ACD pump is used for a number of different fluids:

Lubrication oil, fuel oil, vegetable oil, hydraulic oil and other hydraulic fluids, polymers, emulsions and any non-aggressive fluid with sufficient lubricating properties.

If requested, the ACD pump may be certified according to any of following classification societies: DNV, BV, LRS, ABS, RS, GL, KR or RMR.

1.2 Applications

Typical applications are:

- Lubrication of diesel engines, gears, gas and steam turbines, hydro turbines and paper machines
- Circulation for cooling and filtration in large machineries, hydraulic systems and transformer oil for insulation in transformers
- As transfer pumps onboard vessels, in power plants, oil factories, refineries, tank farms etc

1.3 Installation

The pump is designed to be short coupled directly to an IEC 071 electric motor of flange type. By the angle bracket, the pump might be mounted horizontally or vertically.

The ACD pump can also be mounted on a valve block called T4.

As standard, the pump is delivered including counter flanges (IMO AB design).

For more information about installation, see the Installation and Start-up instruction for low pressure pumps.

2. Pump model code

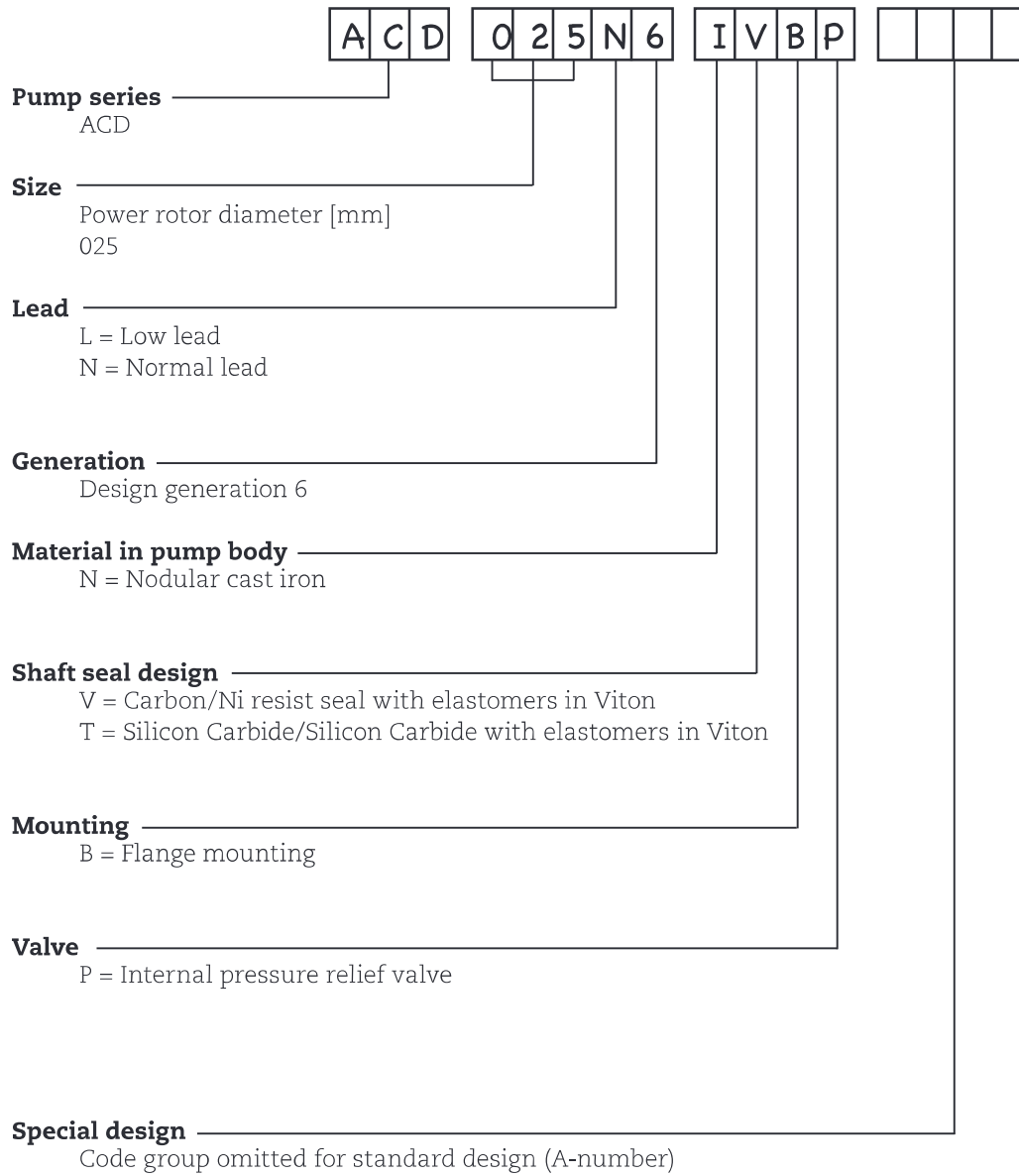

3. Technical Data

3.1 Pressure Information

Pressure relief valve

The pump is equipped with an integral pressure relief valve with internal return, limiting the differential pressure across the pump and protecting the pump. Should the discharge line be blocked, the relief valve will open by the pressure.

The valve is adjustable for different opening pressures. The value of the pressure limit can be set at the factory and should be adjusted at installation (see Installation & Start-up instruction for low-pressure pumps).

The maximum pressure accumulation is 4 bar.

The valve has a maximum set pressure of 7 bar.

Inlet pressure

Minimum inlet pressure (suction capability) is dependent on fluid viscosity and rotation speed. It increases with decreasing viscosity and decreasing speed. Information about minimum inlet pressure for each individual duty case can be obtained from IMO AB or pump selection software WinPump.

Maximum inlet pressure is 7 bar.

Discharge pressure

Maximum discharge pressure is 12 bar.

Differential pressure

Maximum differential pressure is 7 bar but reduced at low viscosities according to table below

Viscosity [cSt]	1,4	2	6	10	>12
Max. diff. pressure [bar]	3,8	4,2	5,8	6,7	7

Refer to your IMO representative or use the pump selection software WinPump to determine the exact operating limits.

3.2 Driver information

Driver type

The pump is designed to be short-coupled to an electric motor with dimensions according to IEC size 071. The motor bearing will have to carry a slight axial load from the rotor set.

With motors delivered from IMO AB, this load will not significantly impact the bearing life expectancy.

Speed

The maximum speed is 3600 rpm. For higher speeds, contact IMO AB.

Rotation

The pump is designed to operate in one rotational direction only, as standard clockwise when facing the shaft end.

For shorter periods of time, a few minutes for emptying a discharge line, the pump may be operated in reverse direction, provided the back pressure is limited to 3 bar.

3. Technical Data

3.3 Sound level

Typical pump sound levels refer to free field conditions at a distance of 1 m from the pump. Noise of driver excluded in the quoted figures. The sound levels are measured at a discharge pressure of 5 bar, 2940 rpm and viscosity 40 cSt, according to ISO-3741.

Sizes	025
Sound level dB [A]	58

3.4 Moment of Inertia

Moment of inertia [10^{-6} kgm²]

Size	025
Value	34

3.5 Fluid viscosity

Lube Line seal (Seal version V):
1,4 – 800 cSt

Fuel Line seal (Seal version T):
1,4-1500 cSt

For higher viscosity, contact IMO AB.

3.6 Fluid temperature

-20 – +90 °C for all types of ACD pumps.

4. Design

4.1 Ball bearing

No ball bearing for the pump is needed since the forces are handled by the ball bearing of the motor.

4.2 Material & design

Model	Material pump	Material rotor	Material idler	Material seal	Material Elastomers
ACD NV	Nodular cast iron	Steel, surface treated	Pearlitic cast iron, surface treated	Carbon/Ni resist	Viton
ACD NT	Nodular cast iron	Steel, surface treated	Pearlitic cast iron, surface treated	Carbide/Carbide	Viton

5. Performance Guide

Typical performance values at 5 bar
 Flow calculated at 26 cSt, power at 260 cSt.

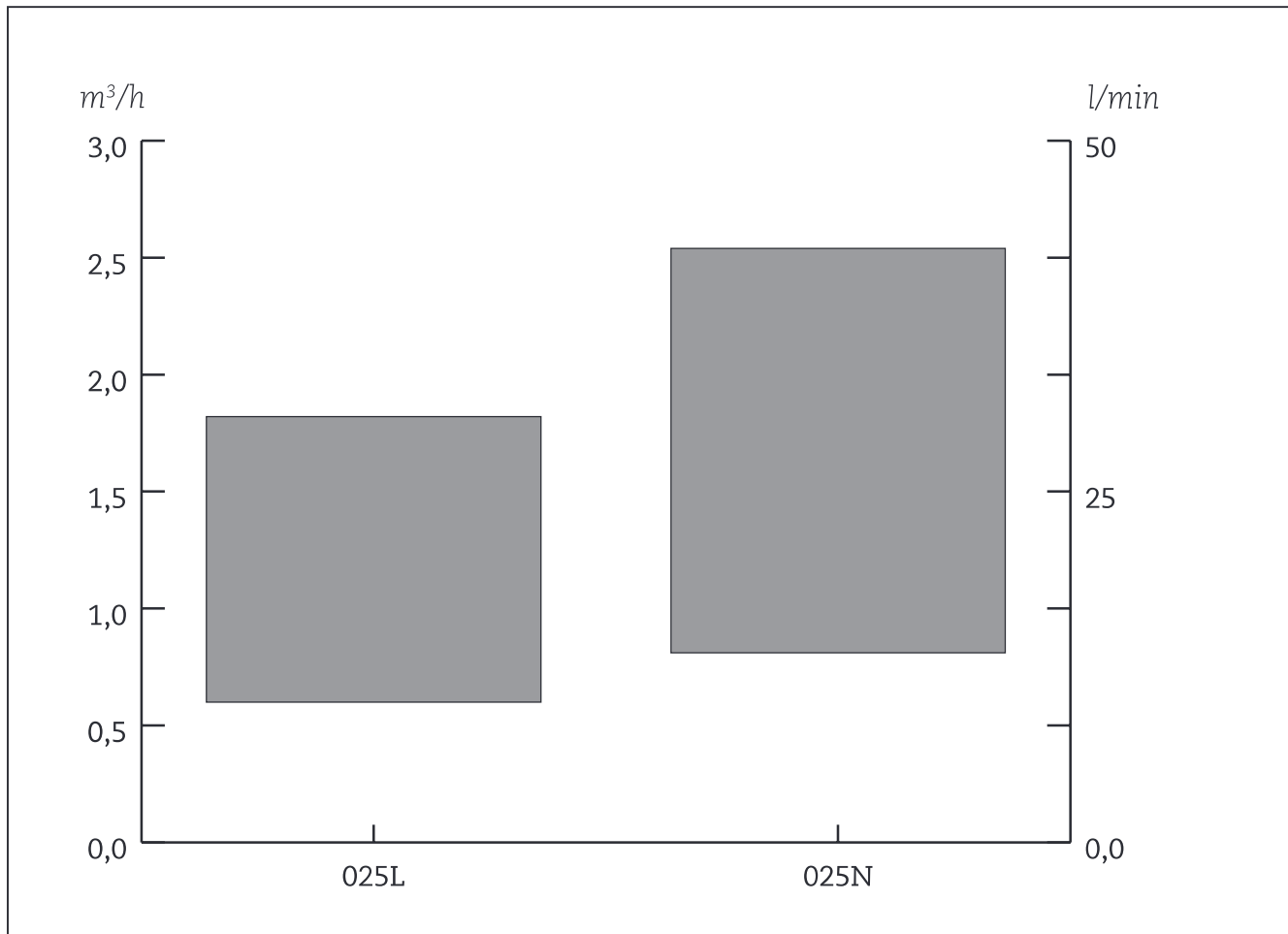

rpm	025L		025N	
	l/min	kW	l/min	kW
1470	10,0	0,3	13,5	0,4
1770	12,9	0,4	17,7	0,5
2950	24,5	0,8	34,1	0,9
3550	30,4	1,0	42,5	1,1

6. Sectional view

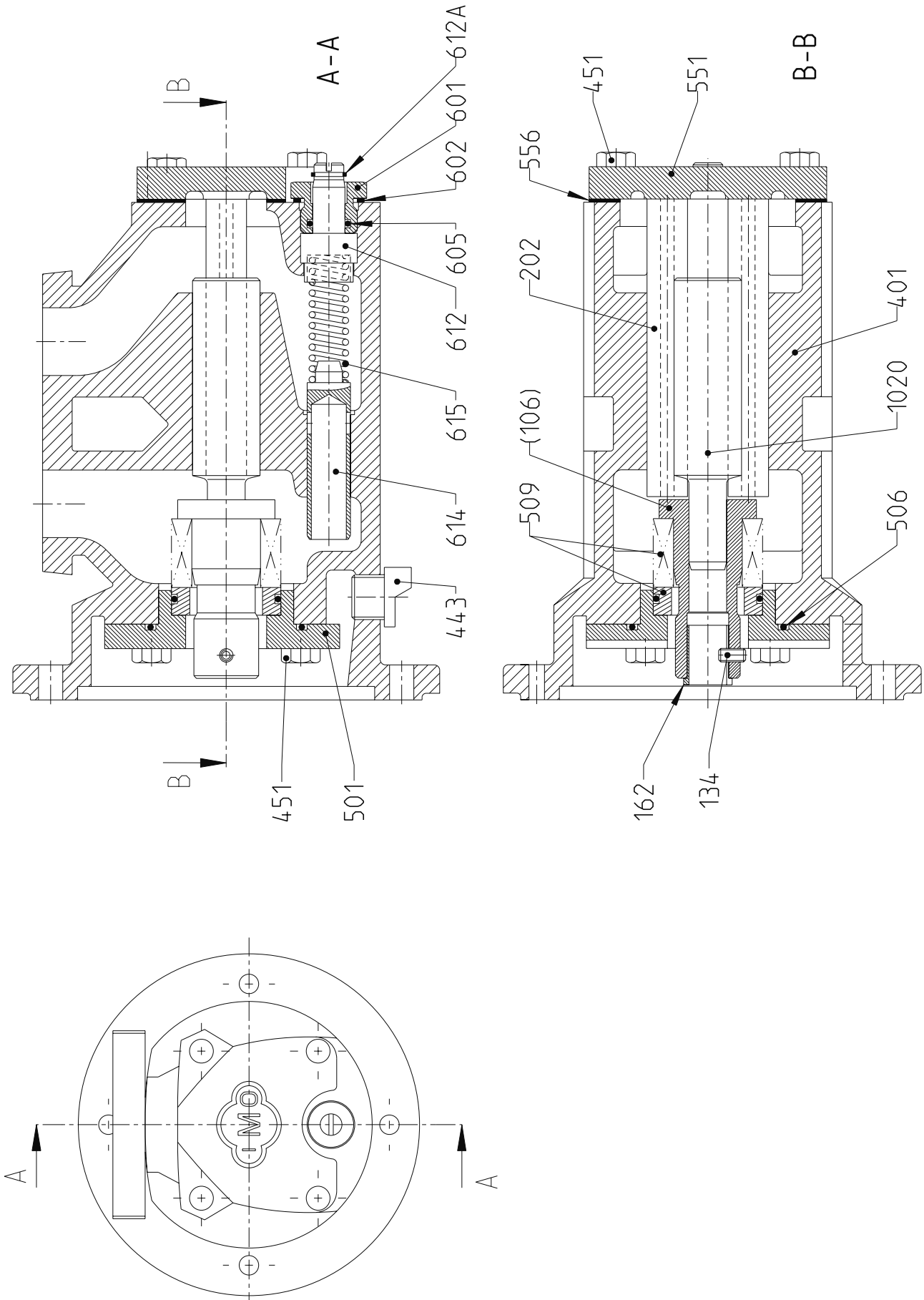

7. List of Components

Pos No	Denomination	Pos No	Denomination
1020	Complete power rotor	509	Shaft seal
(106)	Shaft	551	Rear cover
134	Locking screw	556	Gasket
162	Shaft sleeve	601	Valve cover
202	Idler rotor	602	Sealing washer
401	Pump body	605	O-ring
443	Drip nipple	612	Regulating screw
451	Screw	612A	Retaining ring
501	Front cover	614	Valve piston
506	O-ring	615	Valve spring

Notes:

- Components with Pos No within parenthesis are parts of subassembly

8. Pump Dimensions

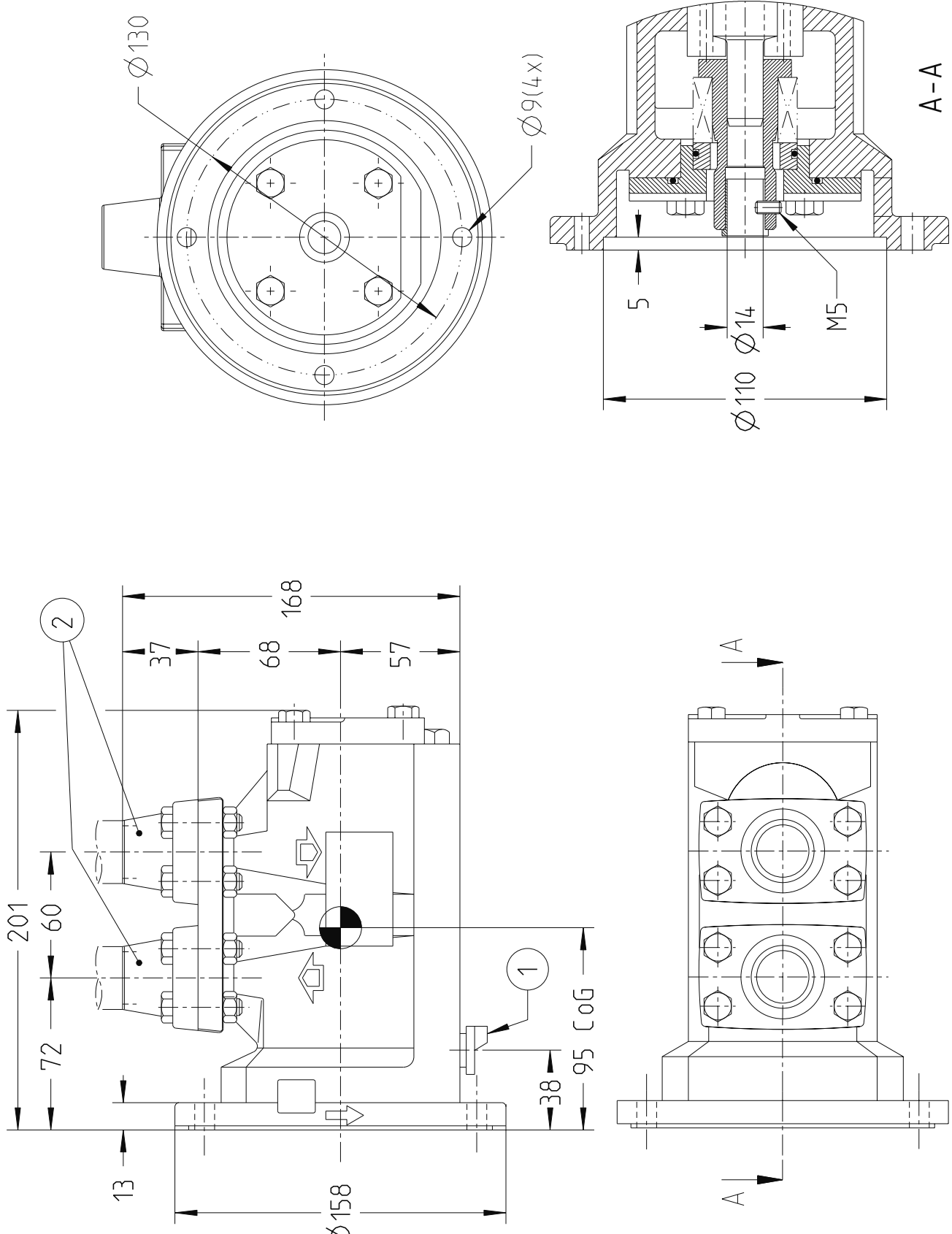

8. Pump Dimensions

Drawing remarks:

(1) Drain. ISO G3/8

(2) For counter flanges dimensions see Pump unit dimensions page 12

Notes:

- Dimensions in mm

- Bare shaft pump approximate 8kg

9. Pump Unit dimensions

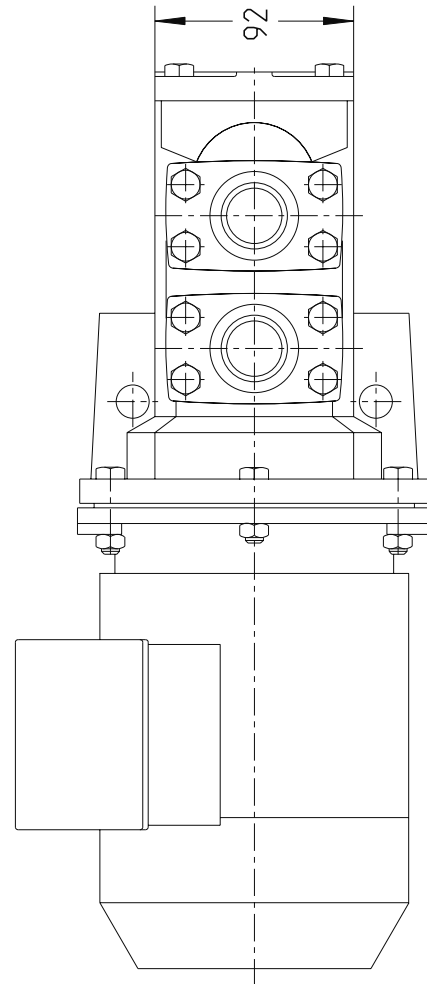
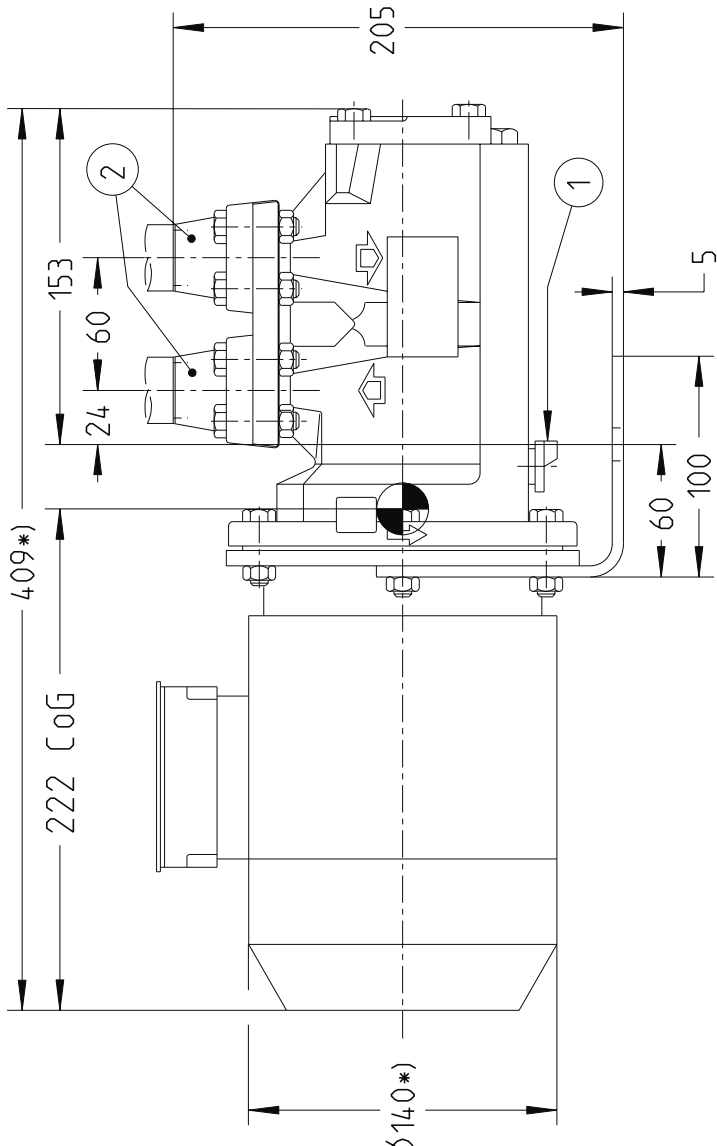
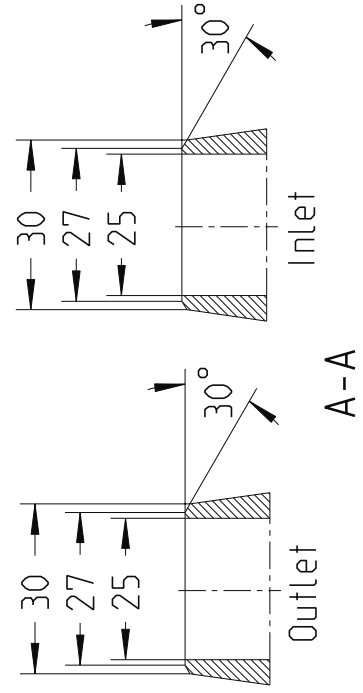
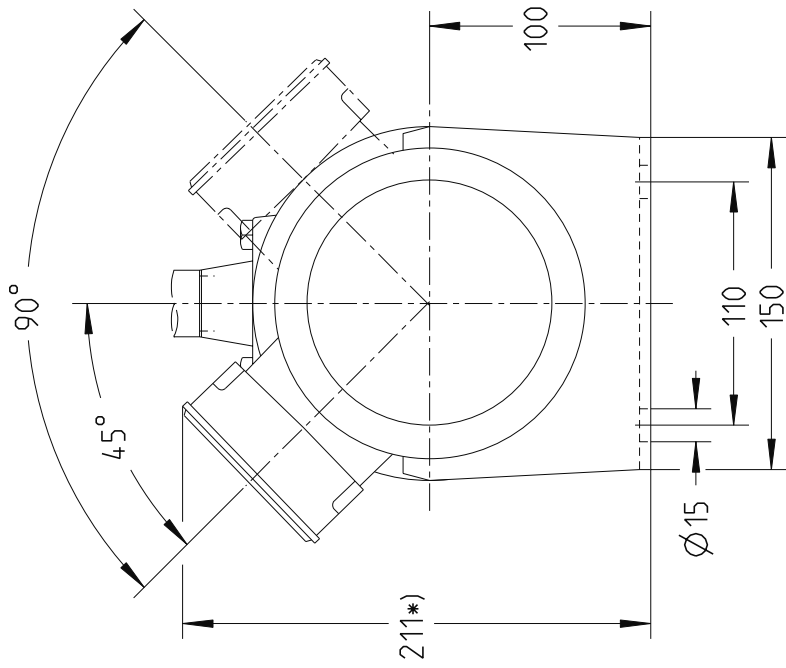

9. Pump Unit dimensions

Drawing remarks:

(1) Drain. ISO G3/8

(2) Butt weld counter flanges of IMO design necessary

*) Dimensions valid for Brook Crompton motor WU-DA 71

Notes:

- Dimensions in mm

- Pump unit approximate 16kg

10. Accessories

A bare shaft pump (Fig. 1) can be ordered with the accessories in fig. 2-5.



Fig. 1 Bare shaft pump



Fig. 2 Set of counter flanges



Fig. 3 Connecting frame

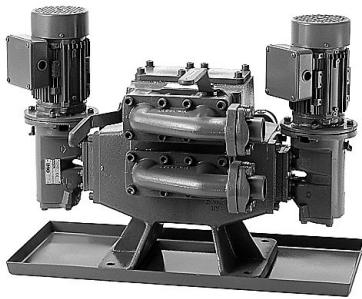

Fig. 4 Valve block

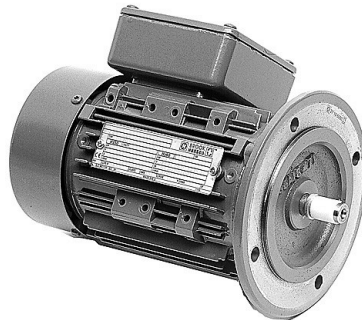

Fig. 5 Electric motor

10.2 Valve block

Two pump units can be mounted to a valve block with inlet and outlet pipe connections. The valve block solution saves space and facilitates installation, maintenance, service and supervision.

11. Maintenance and Service

Spare parts for these pumps are easily available from stock. For detailed information and know-how about service, see the Maintenance & Service Instruction for ACD-pumps or contact IMO AB.

**For latest updates, check:
www.imo.se**