

OPERATING AND MAINTENANCE INSTRUCTIONS

PUMP TYPE 215.10

To

Pump model
Pump number

Our order
Your order
Order date
Reference
Item number
Destination
Plant

Before storing, installation, operation or maintenance read this manual

ABOUT THIS MANUAL

This manual contains detailed instructions for the storage, installation, operation and maintenance of the Houttuin twin screw pump.
To get maximum versatility from the pump, all operators should carefully read and follow the instructions in this manual.
For dismantling and re-assembly chapter 7 has to be consulted.
Please keep this manual in a handy place near the pump-unit.

Warranty

If the pump is used for conditions other than stated in the order confirmation or modified without written consent of Houttuin all guarantee claims become invalid.

Dismantling of the screw pump during the period of guarantee may only be done with a prior written consent of Houttuin BV., otherwise all guarantee claims become invalid.

A copy of the specific warranty terms applicable to your Houttuin product and replacement parts can be obtained from your local Sales and Service Office.

Notice

This document contains proprietary information, which is protected by copyright. All rights are reserved. No part of this document may be photocopied, reproduced or translated to another language without the prior written consent of Houttuin BV.
The information contained in this document is subject to change without notice.

Service

For installation, maintenance and repair of the pump you can always call the Service Department of Houttuin B.V., experienced service people are available on appointment.

Houttuin B.V.
Service Department
Postbus 76
3500 AB Utrecht
The Netherlands
Telephone number: +31 (0)30-2484611
Fax number: +31 (0)30-2411845

SIGNS :



Note for extra attention



Warning for danger

1 INTRODUCTION

1.1 Operating principle ●●●

The Houttuin geared twin screw pump is a rotary positive displacement pump which consists of two counter-rotating screw shafts. The screws on these shafts mesh together retaining a limited clearance and rotating freely inside the liner or pumpcasing bores.

This creates a vacuum (underpressure) that causes the fluid to flow towards the pump. The pumped fluid enters through the suction inlet, the flow is divided and enters at the ends of the pump and travels to the centre of the pump and discharge. The centre part of the cylinders has an open connection towards the discharge.

The torque is transmitted from the driver through the driven screw shaft to the short shaft by means of the timing gears. Both shafts are supported by bearings and are fixed axially at the non-driven end of the shafts.

The bearings are not subjected to any load because of the hydraulic axial balance between the screws.

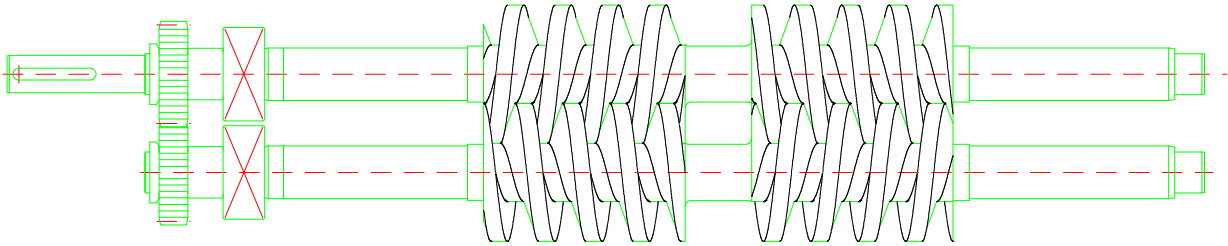

Fig. 1.1 Screws with timing gears

1.2 Shaft sealing arrangements ●●●

Due to their specific design, these pumps are executed with one single mechanical seal. The selection of this seal depends on temperature and properties of the liquid handled as well as on specific operating conditions.

1.3 Relief valve ●●●

The safety valve connects discharge and suction side of the pump to protect the pump against over pressure. The valves are also available with back to tank design.

Relief valve can be utilised to reduce the starting torque. Hand wheel feature permits opening of the valve to lower the pressure and the starting torque during start up.

2 SAFETY REGULATIONS

2.1 Transport ●●●

- Take care when moving the pump. Rough treatment or lifting in an unsuitable way may cause permanent damage. The safe lifting methods are illustrated in chapter Transport.
- The pump should never be lifted by the shaft-end. Relief valve handwheel may have to be removed to accommodate the lifting straps.

2.2 Preparation for installation ●●●

- After receipt, each pump should be thoroughly checked. Damage must be reported to the Houttuin office or representative, and the transportation company immediately. Any claims for damage must be known within one week after receipt of the goods.
- After receipt of the pump, it should be stored in a dry area. The shipping crate is only suitable to protect the pump for a maximum of 90 days after shipment from the factory. This period may be shorter in case of poor atmospheric conditions. Special packing for long term storage can be supplied upon request.

2.3 Earthing ●●●

Ensure that the pumpunit has a proper ground connection.

2.4 Emergency stop ●●●

Houttuin advises to integrate the unit in an emergency stop system.

2.5 Pipe accessories ●●●

Manometers should be placed before and behind the strainer to check when cleaning is to be carried out.

2.6 Check valve ●●●

If the discharge head is high and the viscosity of the liquid is low, it is recommended to install a check valve in the discharge line. This is to protect the pump against reverse rotation in the event of backflow when the pump is shut down. This also allows parallel operation of another pump in the same system.

2 SAFETY REGULATIONS

2.7 Cooling of bearings and timing gears ●●●

- When the temperature of the lubricating oil in the gearbox should reach a maximum level, due to the friction of the gears at higher power consumption, it may be necessary to equip the gearbox with a cooling system to cool the bearings and timing gears.
- Prevent contact with gearbox, surface temperature can rise up to 120 °C (248 °F)

2.8 Start-up ●●●

The pump must not be run unless all protective guards supplied with the equipment are in position.
Be secure the pump cannot be started before maintenance is executed.

2.9 Safety valve set pressure ●●●



The adjustment pressure may only be changed with a prior written consent of Houttuin BV.

3 TRANSPORT

3.1 Transport ●●●

Take care when moving the pump. Rough treatment or lifting in an unsuitable way may cause permanent damage. The safe lifting methods are illustrated below. The pump should never be lifted by the shaft-end. Relief valve hand wheel may have to be removed to accommodate the lifting straps.

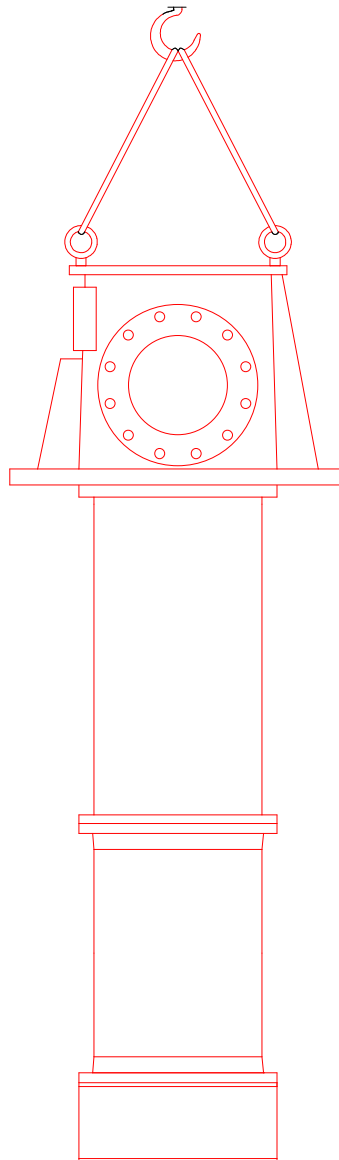

Fig. 3.1 Lifting the pump unit

4 INSTALLATION

4.1 Preparation for installation ●●●

- After receipt, each pump should be thoroughly checked. Damage must be reported to the Houttuin office or representative, and the transportation company immediately. Any claims for damage must be known within one week after receipt of the goods.
- If the pump will not be installed immediately Houttuin advises storage in a dry area.

4.2 Cleaning ●●●

For the protection against corrosion during the period between leaving the factory and installation the pump is preserved. The standard preservation is for a period of 90 days.

Special packing for long term storage can be supplied upon request.

Before installation the external and internal preservations must be removed.

Cleaning:

- The preservation of the external surfaces can be removed with a cloth soaked in mineral spirit or kerosene.
- The internal preservation can be removed with a proper solvent. It is best to rinse the pump with the liquid to be pumped.

4.3 Location ●●●

Position the pump in the tank. Mounting is to be done in the tank top or deck by the mounting flange at the motor bracket.

4.4 Emergency stop ●●●



Houttuin advises to integrate the unit in an emergency stop system.
Houttuin advises to make provisions against accidental start-up of the unit before maintenance activities are executed.

4.5 Earthing ●●●

Ensure that the pump unit has a proper ground connection.



In any case read the manual of the motor.

4 INSTALLATION

4.6 Foundation ●●●

The foundation should be designed in such a way that it can support the weight of pump and motor.

4.7 Alignment of pump and motor ●●●

- Alignment of this pump unit is not possible. The alignment of the coupling can only be checked (see 4.8).
- For good operation it is necessary to mount the pump securely. Nuts must be tightened evenly to prevent distortion.

4.8 Alignment check procedure for 215 series pumps ●●●

- A Connect the dial gauge to the coupling half of the pump.
- B Set the gauge to zero.
- C Rotate the shaft once after which the gauge should again read zero.
- D Rotate the shaft a $\frac{1}{2}$ revolution. The deviation indicated by the gauge must be less than 0,25 mm/0,010".

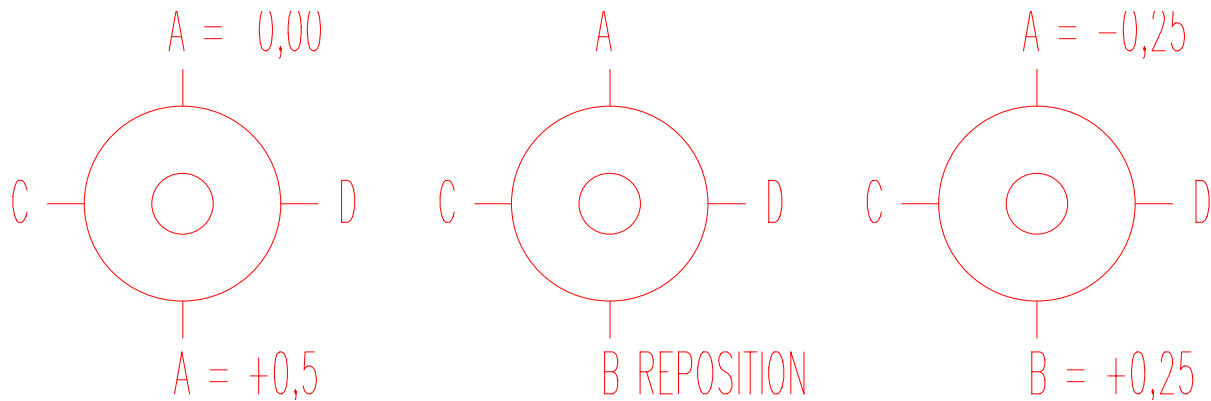

Fig. 4.1 Alignment

- E Set the gauge to zero and check the distances.
- F Point A and B are aligned if the deviation is below 0,25 mm/0,010".
- G Repeat the procedure for points C and D.

4 INSTALLATION

- H If the deviation at any position exceeds 0,25 mm., contact Houttuin for advice.
- I The motor can now be mounted. Because of the centring collar in the motor bracket and the mating centring ring of the motor, it is self aligning.

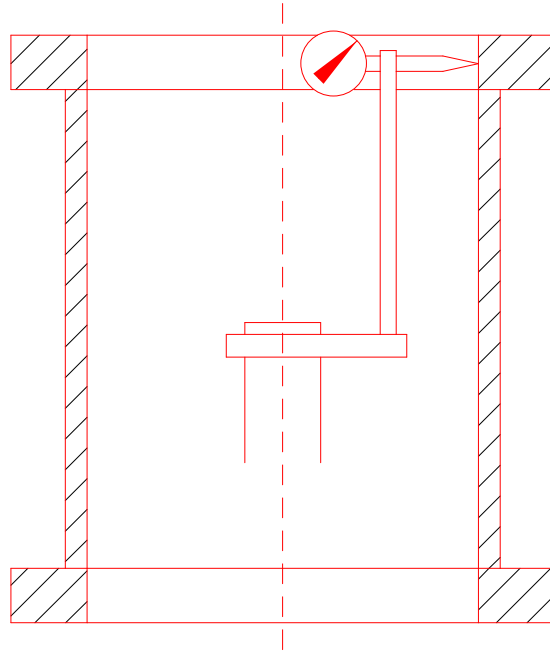

Fig. 4.2 Alignment



The pump must not be run unless all protective guards supplied with the equipment are in position.

4 INSTALLATION

4.9 Piping design ●●●

- Because the screw pump has close clearance between its working parts, it is essential that the system is carefully and thoroughly cleaned before the connection is made.
- After installing the pump unit on foundation, the pipelines can be connected. For correct location of pipes, refer to the pump drawing. Pipe adapters should be short and direct.
Bends should be laid out with the largest possible radius. All pipes should be fixed independent from the pump flanges. Pipelines that may have to withstand elevated temperature must be provided with expansion joints to absorb expansion of the pipe. Tensional or compressing loads on the pump could result in distortions causing wear or even seizure.
- To check whether the pipes are correctly aligned, bolts should be inserted through the boltholes of pump flange and pipe flange. If these bolts can be pushed in by hand and the flanges are parallel, the pipelines are fitted stress free. Some clearance between the pump and pipe flange should be maintained to allow for the flange gaskets.

4.10 Pipe accessories ●●●

4.10.1 Strainer ●●●

It is not necessary to use a strainer; the pump is equipped with a coarse suction filter. Should however the use of a strainer be desirable, then the strainer should be made of reinforced 20 mesh wire. The total free flow area must be 4 to 5 times larger than the cross sectional free flow area of the suction line. If the medium has a viscosity above 20 cSt (100 SSU), the area should be enlarged to 5 or 6 times the size of the pipe.



Manometers should be placed before and behind the strainer to check when cleaning is to be carried out.

The pressure loss over the strainer should be no more than 127 mm Hg (5 inches Hg). In general, suction strainers can be used with any liquid except when the viscosity is very high. In these cases, the strainer should be eliminated and careful cleaning of the suction line is recommended to remove all foreign particles.

4.10.2 Check valve ●●●

If the discharge head is high and the viscosity of the liquid is low, it is recommended to install a check valve in the discharge line. This is to protect the pump against reverse rotation in the event of backflow when the pump is shut down. This also allows parallel operation of another pump in the same system.

5 OPERATION

5.1 Before start-up ●●●

1. Inspect all pipelines, check for any leakage or stress in the system. Clean all pipes, valves, tanks and filters to be sure all foreign materials have been removed. Check all valves and meters.
2. Check to be sure the pump shaft can rotate without difficulty; if not, the cause of blockage or friction should be corrected. Each pump is tested before leaving the factory, but transport could have had some effect.
3. Resistance in turning the shaft must be expected with pumps equipped with mechanical seals.
4. Check the direction of rotation of pump and motor to be sure they are the same. The pump is fitted with an arrow to indicate the direction of rotation.
5. Fill the gearbox with oil (if applicable). Refer to the lubrication chart for type and quality of the oil. The pumps should always be filled with liquid before starting. (See chapter Maintenance)
6. If the pump is fitted with mechanical seals it is most important to fill the pump before start-up either with the pumped liquid or with a neutral compatible liquid to protect the seal faces from running dry.
7. Auxiliary flushing or lubrication lines should be examined for any damage or distortions.
8. Open all valves.
9. If the pump is provided with a safety valve with handwheel, it should be opened completely using the handwheel.
10. In case the timing gearbox is provided with a cooling coil, the quantity of cooling liquid required depends on the pump size (See chapter 6)
11. Read the driver instruction manual to determine if a special coupling is required.
12. If the pump has a suction lift, the de-aeration valve in the discharge line should be opened and the pipe filled with liquid. This is only necessary for new installations or for reinstalled pumps.

5.2 Start-up ●●●

1. If the pump is provided with a heating feature, this heating should be turned on until the pump has reached its normal operating temperature, after that heating must be turned off and the motor can be started.
2. As soon as the pump has reached the rated speed, the safety valve should be closed.
3. The absorbed power and the suction and discharge pressure should be checked against the data sheet.



Prevent contact with gearbox, surface temperature can rise up to 120 °C (248 °F)

5 OPERATION

5.3 While the pump is in operation ●●●

1. Check the temperature of bearings and gearbox. It is to be expected that this temperature will be high in these areas at start-up, and after a short period of time the temperatures will settle down to operating temperature.
2. If the pump is part of a closed system, the discharge line should be de-aerated during operation.
3. When the pump has reached operating conditions, anyway after 24 hours, check the tightening torques of the bolts and nuts (See chapter 6). Repeat this check after one week of operation.

5.4 After a long time shut down ●●●

The pump should not remain unused for long periods. The pump should be operated once a week if possible. If the pump will be idle for longer periods, it is advisable to rotate the screwshafts by hand if possible, on a two-weekly schedule.

It is easy to detect if any of the internal parts are contacting by rotating the shaft by hand.

When starting after a long time shut down, let the pump run for a short period without pressure to allow proper wetting of all rotating parts.

6 MAINTENANCE

Because of their construction Houttuin screw pumps require a minimum of inspection and maintenance. However, the following instructions should be followed to ensure trouble free operation.

6.1 Schedule ●●●

Weekly:

1. Let the unused pump run for 30 minutes at full load.
2. Check any automatic controls and / or regulating valves.

Quarterly:

1. Check flange bolts and nuts for correct tightness.
2. Check functioning of the pressure relief valve.

Yearly:

1. Check the alignment of the coupling halves, preferably immediately after ending the pump operation, while the temperature is still at operating level.
2. Check capacity and absorbed horse power. Capacity- and power loss will indicate wear.
3. In case of wear, screw shafts and cylinders must be checked for damage.
4. Check the screw flank clearance, as well as the clearance between the timing gears.

Every 4000 to 5000 working hours

1. The axial clearance of the bearings is to be checked.
The axial clearance of the shafts should not exceed 0,2 mm / 0,0080".
2. If the clearance between the timing gears is more than 0,5 mm / 0,0020" the timing gears should be replaced.

Emergency stop:



Houttuin advises to make provisions against start-up of the unit before maintenance activities are executed.

6 MAINTENANCE

6.2 Spare parts ●●

To reduce the time the pump is out of order, it is advisable to keep the following parts in stock:

- 1 set of screw shafts complete with timing gears,
- 1 set of bearings,
- 1 set of gaskets,
- 1 mechanical seal.

When ordering spare parts, the following information should be indicated on the purchase order:

- Pump serial number (see title page).
- Pump series (see title page).
- Code number of required spares as given in the parts list (see supply).



To ensure a safe and good functioning of the pump we advise to buy genuine spare parts according the specifications in the partslist.

6 MAINTENANCE

6.3 Bolt tightening torques ●●●

material	steel 8,8	steel 9 SMn 28	bronze CuZn 35 Ni 2	stainless steel X 10 CrNiMoTi
application	tap bolt stud bolt socket screw	stud bolt	stud bolt	tap bolt stud bolt
diameter d (mm)	torques (Nm)			
M6	10		7	8
M8	25		20	20
M10	50		35	40
M12	80		60	70
M16	200	150	100	160
M20	400	280	210	210
M24	680	480	360	360

Conversion factors

1N	(Newton)	= 1/4,45	= 0,225 lbf
1m	(meter)	= 1000mm = (1/305x10 ³)	= 3,279 ft
1Nm	(Newtonmeter)	= 1/4,45x1/305x10 ³	= 0,737 lbfft

7 DISMANTLING AND RE-ASSEMBLING

7.1 General instructions for dismantling the screw pump ●●●



Dismantling of the screw pump during the period of guarantee is only allowed with a prior written consent of Houttuin BV., otherwise all guarantee claims become invalid.

Before dismantling is started be secure the following actions are finished:

- Disconnect energy supply of the motor.
- Close all valves in the suction and pressure lines.
- Drain the fluid from the pump.
- Drain the oil from the gearbox.
- Remove pressure and vacuum gauges.
- Remove, when necessary, the suction and pressure pipe.

7.2 Dismantling ●●●

- Mark the parts, which will be dismantled.
- Use correct tools.
- Before reassembly clean the parts.
- Replace worn bearings.
- Replace flange packings.
- Replace lip seals and 'O'-rings.
- For the correct bolt tightening torques see chapter 6.

7.3 Reassembly ●●●

- After reassembling the pump, the pump unit must be aligned.
(See chapter 4)
- After aligning the pump unit the protective guards must be placed in position.
- After finishing the reassembly follow the start-up procedure described in chapter 5.



The Houttuin screw pumps are precision machines and it is obligatory that trained and experienced personnel carry out dismantling and re-assembly. We advise Houttuin personnel. Detailed dismantling instructions are available on request.

8 TROUBLE SHOOTING

Fault finding chart

	Pump fails to prime	Lack of output	Hydraulic noise	Motor overloading	Irregular delivery	Pump seizes	Pump becomes warm	
x								CAUSE Rotation incorrect
								ACTION Reconnection of E-motor
x								Pump is not filled
x	x	x						Air leaks in suction system
								Check flange connections
x	x	x						Shaft seal(s) leaking
x	x	x						Vacuum too high
								Check NPSHA + R
x	x				x		x	Relief valve leaking
								Check set pressure
x	x	x	x	x			x	Viscosity too high
								Check data-/performance sheet
	x							Motor speed too low
	x	x						Vapour pressure of the medium too high
	x	x			x			Suction pipe too close to the tank bottom
	x	x			x			Retention time of fluid in tank too short to separate the air
		x	x				x	Incorrect alignment
		x	x				x	Motor speed too high
		x						Velocity in pipeline too high
			x				x	Discharge pressure too high
						x		Foreign matter in screw clearances
			x		x	x		Damaged ball bearings
			x		x	x		Pipe work incorrectly aligned to pump casing
		x						Suction pipe too small

9 LONG TERM STORAGE

When pumps are stored or unused for long periods, rust may occur. Since rust has an adverse effect on the working life of the pump, it is advisable to apply protection to the bare metal surfaces.

9.1 Prescription of preservation - internal ●●●

The inside of the gearbox and pump casing should be preserved with a proper preservation medium. For example:

Exxon RS 335
Shell Ensis oil 1
Valvoline Ritzol R6
Mobil Arma 523 / 524

9.2 Shaft seals treatment ●●●

The shaft seals should be greased with a grease which can be removed later.

9.3 Prescription of preservation - external ●●●

The external machined parts must be protected with for example:

Exxon R6 324
Shell Ensis MD
Valvoline 846 K19



All drilled and tapped holes are to be plugged. Flanges are to be covered with blanks. Periodical checks of the stored pump should be made. The screwshafts are to be turned once per 14 days. After rotation the position of the shafts must be different from what they were before the rotation.

10 ENCLOSURES