

SMART SENSE

INTELLIGENT PUMP CONTROL AND MONITORING SYSTEM

You've come to expect precision, long-life and maximum energy efficiency from CIRCOR's Allweiler, IMO, Houttuin and Warren pumps. With our Smart Sense system you can comfortably achieve this expected performance as our control system incorporates various real-time readings to optimally adjust pump operations.

Our patented **cavitation monitoring** and **wear detection** features set the benchmark for the screw pump industry.



CONTROL AND MONITORING FEATURES

Cavitation Monitoring

Cavitation measurements across the pump's rotating screws feed the control system which adjusts operating parameters accordingly:

- Preventing cavitation pump wear
- Protecting film support (three screw pumps)
- Optimizing pumping with air/liquid mixtures (two screw & progressive cavity pumps)

Wear Detection

Active measurement of housing and rotating screw wear enables predictive maintenance scheduling

Pressure Monitoring

Inlet and outlet pressure readings adjust pump controls to ensure compliance with process requirements

Temperature Monitoring

Fluid and pump component temperature readings log process conditions and, when applicable, automate controls for cooling or heating pump support systems

Vibration Monitoring

Horizontal and vertical vibration reading track micro pump movements as process conditions evolve

Seal and Lubrication System Monitoring

Temperature, pressure and leak detection monitoring identify undesired performance before failures occur

Remote Communications

Remote operations, monitoring and/or alarms enable centralized equipment, management with limited on-site equipment management

Smart Monitoring

Monitoring software reads, logs and displays pump operating and performance characteristics.

- Includes programmable alerts, alarms and reports
- Electronic log book of operating parameters and maintenance
- Incorporated in CIRCOR's proprietary controls systems
- Feed for customer's existing equipment control systems
- Automatic spare parts purchasing and inventory control

Control System

Proprietary control system optimally operates the pumps according to desired process conditions and real-time conditions as noted above. Optional local or central control system operations.

PERFORMANCE BENEFITS ACHIEVED WITH SMART SENSE

Precise Flow Control, Optimization and Measurement:

- Reduced energy consumption and cost as pump speed adapts to changing fluid and process conditions
- Predictable pump and process performance as pump automatically adjusts to deliver prescribed volumes
- Faster, more complete loading and unloading operations as pumps adjust to account for a decreasing suction head and increasing volumes of air in the fluid

Condition Based Monitoring System:

- Minimal unplanned maintenance down time as pump performance is recorded and monitored
- Reduced maintenance cost as predictive parts replacement reduces more costly equipment repairs
- Real time system diagnosis and optimization as process conditions fluctuate

Remote Operations and Maintenance Monitoring:

- Elimination of control system redundancies via incorporation of a plant-level control system
- Reduced cost for on-site supervision and monitoring as the task is centralized
- Increased safety as hands-on equipment monitoring and operations is eliminated

SMART SENSE OVERVIEW

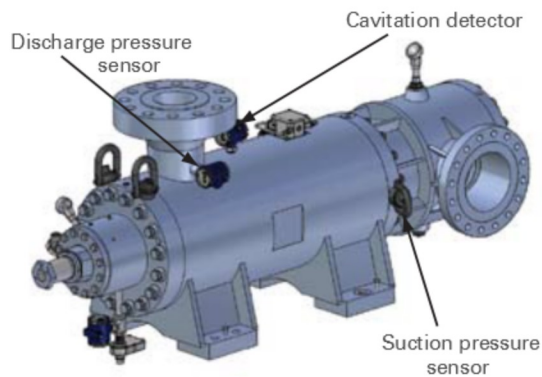

POWER ROTOR BORE CUTAWAY

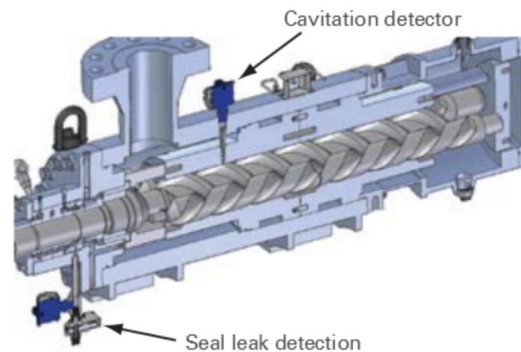

IDLER ROTOR BORE CUTAWAY

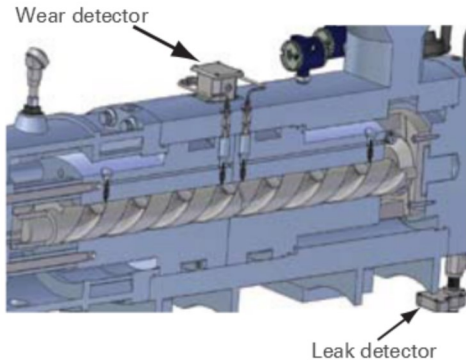

CIRCOR

1710 Airport Road
Monroe, NC 28110-5020
Tel: +1.704.289.6511
Tol: +1.877.853.7867

CIRCOR Product & Services



ALLWEILER® HOUTTUIN™ IMO®
ROSSCOR® TUSHACO® WARREN®

ALLWEILER® HOUTTUIN™ IMO® ROSSCOR® TUSHACO® WARREN®

CIRCOR, Allweiler, Imo, Rosscor, Tushaco and Warren are registered trademarks and Houttuin is a trademark of CIRCOR international or its subsidiaries in the U.S. and/or other countries. ©2018 CIRCOR International. All rights reserved. GB-OG016-24855-5/18