



**Instruction Manual
and
Parts List
for
CIG Mechanical Seal
Single Pumps**



WARNING

This manual should be read thoroughly prior to pump installation, operation or maintenance.

SRM00050

Rev. 2 (01-0030)

January 24, 2001

(was CIG-4)



READ THIS ENTIRE PAGE BEFORE PROCEEDING

FOR THE SAFETY OF PERSONNEL AND TO PREVENT DAMAGE TO THE EQUIPMENT, THE FOLLOWING NOMENCLATURE HAS BEEN USED IN THIS MANUAL:

	DANGER
Failure to observe the precautions noted in this box can result in severe bodily injury or loss of life.	

	WARNING
Failure to observe the precautions noted in this box can cause injury to personnel by accidental contact with the equipment or liquids. Protection should be provided by the user to prevent accidental contact.	

CAUTION	ATTENTION
Failure to observe the precautions noted in this box can cause damage or failure of the equipment.	

Non-compliance of safety instructions identified by the following symbol could affect safety for persons: <div style="text-align: center;"></div>	Safety instructions where electrical safety is involved are identified by: <div style="text-align: center;"></div>	Safety instructions which shall be considered for reasons of safe operation of the pump and/or protection of the pump itself are marked by the sign: <div style="text-align: center;">ATTENTION</div>
--	---	---

CONTENTS

SAFETY AND TABLE OF CONTENTS	A
A. GENERAL INSTRUCTIONS	1
B. INTRODUCTION	1
C. DESCRIPTION OF EQUIPMENT	1
D. PUMP MODEL IDENTIFICATION	1
E. ORDERING INSTRUCTIONS	2
F. OPERATION	2
G. PUMP DISASSEMBLY PROCEDURES	2
H. INSPECTION OF PARTS	5
I. MACHINING INSTRUCTIONS	5
J. SPARE PARTS AND KITS	6
K. PUMP REASSEMBLY PROCEDURES	7
L. TROUBLESHOOTING	10

ATTENTION
<i>If operation of this pump is critical to your business, we strongly recommend you keep a spare pump or major repair kit in stock at all times. As a minimum, a minor repair kit (o-rings, gaskets, shaft seal and bearings) should be kept in stock so pump refurbishment after internal inspection can be accomplished.</i>

A. GENERAL INSTRUCTIONS

The instructions found herein cover the disassembly, assembly and parts identification of CIG single mechanical seal pumps.

NOTE: Individual contracts may have specific provisions that vary from this manual. Should any questions arise which may not be answered by these instructions, refer to the General Instructions Manual, CA-1, provided with your order. For further detailed information and technical assistance please refer to Imo Pump, Technical/Customer Service Department, at (704) 289-6511.

This manual cannot possibly cover every situation connected with the installation, operation, inspection, and maintenance of the equipment supplied. Every effort was made to prepare the text of the manual so that engineering and design data is transformed into the most understandable wording. Imo Pump must assume the personnel assigned to operate and maintain the supplied equipment and apply this instruction manual have sufficient technical knowledge and are experienced to apply sound safety and operational practices which may not be otherwise covered by this manual.

In applications where equipment furnished by Imo Pump is to become part of processing machinery, these instructions should be thoroughly reviewed to ensure proper fit of said equipment into overall plant operational procedures.



WARNING

If installation, operation, and maintenance instructions are not correctly and strictly followed and observed, injury to personnel or serious damage to pump could result. Imo Pump cannot accept responsibility for unsatisfactory performance or damage resulting from failure to comply with instructions.

B. INTRODUCTION

This instruction manual covers CIG single mechanical seal pumps. This series of pumps has been designed for use in hydraulic, lubricating seal and fuel oil applications. The model and design construction of each pump can be identified by the designator code on the pump nameplate. Definitions of model designators are identified in Figure 1.

C. DESCRIPTION OF EQUIPMENT

The CIG single mechanical seal pumps are positive displacement, internal gear pumps consisting of a single shaft that runs through the center of pump housings. This shaft drives the external gears (pinion gears) which in turn drives the internal gears (ring gears). Fluid is carried between the internal and external gear teeth of each pump and is discharged as the teeth mesh. The pinion and ring gears are separated in each pump by a crescent which is a sealing element in the pump between inlet and discharge ports.

D. PUMP MODEL IDENTIFICATION

This instruction manual covers the Imo CIG single mechanical seal pumps.

The model of each pump is identified on the pump nameplate. Refer to Figure 1 for instructional keys when using this manual.

E. ORDERING INSTRUCTIONS

When corresponding with Imo Pump regarding CIG Single Series pumps, refer to the pump nameplate, this instruction manual, and the assembly drawing as instructed below:

1. From pump nameplate, record the pump model number. Also record the manufactured lot number and date (these are stamped on the housing near the nameplate).
2. Record instruction manual number, revision and date.
3. From the instruction manual, record the figure numbers that apply to the replacement part(s)
4. From the assembly drawing or instruction manual (see Table 1, Pump Parts List) provide the IDP number(s) and names for the replacement part(s).
5. Give the above information to your Imo service representative.

Imo sales and service representatives are listed herein and in General Instruction Manual, CA-1.

F. OPERATION

LIQUID LIMITATIONS

Never operate with fluids that are corrosive to iron, steel, aluminum or bronze. The pump is designed for fluids having the general characteristics of oil.

CAUTION

ATTENTION

Operating conditions, such as speed, fluid viscosity, temperature, inlet pressure, discharge pressure, filtration, duty cycle, drive type, mounting, etc. are interrelated. Due to these variable conditions, the specific application limits may be different from that of the operational limitations. This equipment must not be operated without verification that operating requirements are within its capabilities.

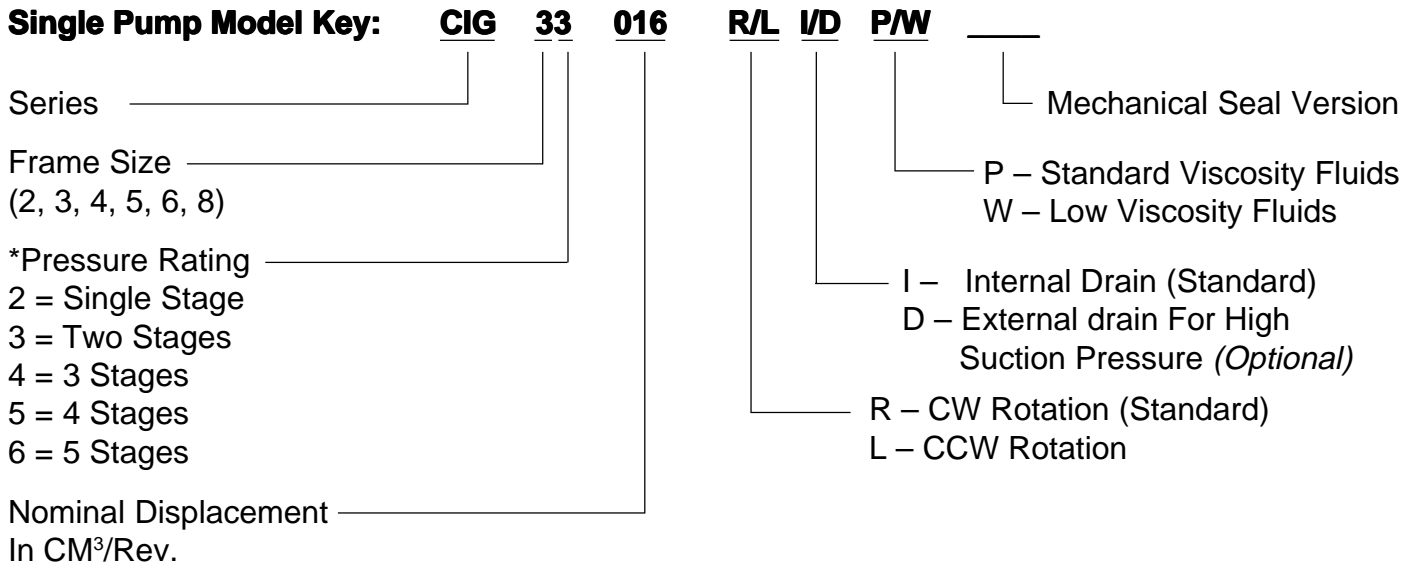

Note: Mechanical shaft seals are available for all frame sizes except frame 2.

Figure 1 – Series Single Pump Configurations With Mechanical Seals

G. PUMP DISASSEMBLY

Refer to Assembly 1 for one stage (X1, X2) pumps
Refer to Assembly 2 for multistage (X3, X4, X5, X6) pumps

1. Remove drive key (36)
2. Remove capscrews (38) and end cover (15) with O-ring (35).
3. Remove capscrews (39) and washers (34) (Washers not used on single stage units).

CAUTION	ATTENTION
<p>In next step, ring gear (12), pinion (11) and key (13) will be removed. If ring (12) and pinion (11) are to be reused, identify them, with a marker or the like, so it can be determined to which housing they belong (if there is more than one housing in pump) and which direction face of each gear was positioned in housing. Do not mark with scribe or punch as this may leave a burr or high spot which could lead to pump damage or seizure. If key (13) is to be reused, mark it so that it can be assembled into its original stage and facing its original direction.</p>	

4. Remove square housing (4), ring gear (12), pinion gear (11) and key (13) from shaft (6). Do not permit dowel pin (37) to drop as housing (4) is removed. Remove dowel pin (37) from square housing (4), front cover (1), or back of round housing (3) whichever is applicable.

NOTE: If square gear housing (4) will not slide easily off shaft (6) and pump is a one stage unit, clamp square housing (4) in a vise with front cover (1) free. With a soft headed hammer, tap alternately on mounting ears of front cover (1) until there is sufficient gap to insert a wedging device. Pry gap until square housing (4) is free to slide off shaft (6). If pump has more than one stage, clamp pump in a vise with square housing (4) free. With a soft headed hammer, tap alternately on edges of square housing (4) to separate it from round housing (3) until there is sufficient gap between the square (4) and round (3) housings to insert a wedging device. Pry gap until square housing (4) is free to slide off shaft (6).

CAUTION	ATTENTION
<p>Take care not to damage either faces that are being pried against or O-ring (41) with prying device.</p>	

CAUTION	ATTENTION
<p>If gear housing (4) did not slide off easily because its bushing (53) was jammed on shaft (6), ball bearing (31) was most likely damaged when housing (4) was pried off and it must be replaced. Alternately, if gear housing (4) will not slide off easily because its rabbet was jammed in counterbore of barrel (8) or front cover (1), whichever is applicable, ball bearing (31) may not have to be replaced.</p>	

CAUTION	ATTENTION
<p>If gear housing (4) did not slide off easily because its bushing (53) was jammed on shaft (6), ball bearing (31) was most likely damaged when housing (4) was pried off and it must be replaced. Alternately, if gear housing (4) will not slide off easily because its rabbet was jammed in counterbore of barrel (8) or front cover (1), whichever is applicable, ball bearing (31) may not have to be replaced.</p>	

NOTE: If housing (4), ring gear (12) or pinion gear (11) can not be removed without applying excessive force, pump should be returned to lmo for further disassembly and inspection.

- 5. If unit has only one stage, proceed to step #9. If pump has more than one stage, continue with step #6.
- 6. Remove housing tube (8). Remove O-rings (41) from counterbores of square housing (4) and round housing (3).

NOTE: Neither housing tube (8) nor O-ring (41) need be removed from round housing (3) unless O-rings (41) are to be replaced. (Replacing O-rings is good practice when a pump is disassembled after extended service or if damaged during disassembly.)

CAUTION	ATTENTION
<p>In next step, ring gear (12), pinion (11) and key (13) will be removed. If ring (12) and pinion (11) are to be reused, identify them, with a marker or the like, so it can be determined to which housing they belong (if there is more than one housing in pump) and which direction face of each gear was positioned in housing. Do not mark with scribe or punch as this may leave a burr or high spot which could lead to pump damage or seizure. If key (13) is to be reused, mark it so that it can be assembled into its original stage and facing its original direction.</p>	

- 7. Remove round housing (3), ring gear (12), pinion gear (11) and key (13) from shaft (6). Do not permit dowel pin (37) to drop as round housing (3) is removed. Remove dowel pin (37) from either round housing (3) or front cover (1) whichever is applicable.

NOTE: If round gear housing (3) will not slide easily off shaft (6) and this is the last round housing (3) to be removed, clamp round housing (3) in a vise with front cover (1) free. With a soft headed hammer, tap alternately on mounting ears of front cover (1) to separate it from round housing (3). When there is sufficient gap between front cover (1) and round housing (3), insert a wedging device. Pry gap until round housing (3) is free to slide off shaft (6). If there are several round housings (3) to remove, clamp pump in a vise leaving rearmost round housing (3) free. Position a wedging device between the rearmost round housings (3) the round housing (3) in front of it. Pry gap until rearmost round housing (3) is free to slide off shaft (6).

CAUTION	ATTENTION
<p>Take care not to damage either faces that are being pried against or O-ring (41) with prying device.</p>	

CAUTION	ATTENTION
<p>If gear housing (3) did not slide off easily because its bushing (53) was jammed on shaft (6), ball bearing (31) was most likely damaged when housing (3) was pried off and it must be replaced. Alternately, if gear housing (3) will not slide off easily because its rabbet was jammed in counterbore of barrel (8) or front cover (1), whichever is applicable, ball bearing (31) may not have to be replaced.</p>	

NOTE: If housing (3), ring gear (12) or pinion gear (11) can not be removed without applying excessive force, pump should be returned to lmo for further disassembly and inspection.

CAUTION	ATTENTION
<p>Be sure that all gear keys (13) are removed before removing shaft (6). If not, front cover (1) face will be damaged.</p>	

CAUTION	ATTENTION
<p>Handle 'shaft/bearing housing' assembly with great care since any significant cocking of bearing housing (9) assembly relative to shaft (6) could damage ball bearing (31) or mechanical seal (51). If shaft (6) is to be set down on a work surface, it should not be allowed to rest on bearing housing.</p>	

8. Repeat steps 6 and 7 until all round housings (3) are removed.
9. Remove O-ring (41) from front cover (1 if it did not come off with last housing removed).
10. Remove socket head cap screws (75) and bearing retainer (70) with lip seal (32), where applicable.
11. If lip seal (32) is included in the bearing retainer (70) and is to be replaced, remove it from the bearing retainer (70) and discard.
12. Remove socket head cap screws (42).
13. Reinstall bearing retainer (70) and socket head cap screws (75).
14. Remove shaft (6) from front cover (1). Bearing housing (9), seal spacer (74), ball bearing (31), bearing retainer plate (70), cap screws (75) and O-rings (40, 80) will come off with shaft as an assembly.

CAUTION	ATTENTION
Be sure that all gear keys (13) are removed before removing shaft (6). If not, front cover (1) face will be damaged.	

CAUTION	ATTENTION
Handle 'shaft/bearing housing' assembly with great care since any significant cocking of bearing housing (9) assembly relative to shaft (6) could damage ball bearing (31) or mechanical seal (51). If shaft (6) is to be set down on a work surface, it should not be allowed to rest on bearing housing.	

15. Remove O-rings (40 and 80) from bearing housing (9).
 NOTE: If neither ball bearing (31) nor seal (51) are to be replaced or inspected, disassembly is complete. If either of these components are to be replaced or inspected for any reason, proceed as below.
16. Place inboard face of bearing housing (9) on the clean, smooth surface of an arbor press with coupling end facing up.
17. Remove socket head capscrews (75) and bearing retainer (70).
18. Remove ball bearing snap ring (33).
19. Press shaft (6) out of bearing housing (9) by pushing squarely on coupling end of shaft (6). Rotating member of seal (51) and its seal spacer (74) will remain on shaft while ball bearing (31) and stationary member of seal (51) will remain in bearing housing (9).

CAUTION	ATTENTION
Be sure to hold onto shaft (1) when pressing it out of bearing housing (9).	

CAUTION	ATTENTION
Take extreme care during this step to avoid damaging seal faces.	

20. Remove ball bearing (31) from bearing housing (9) by lightly tapping it out with brass rod from inboard side.

CAUTION	ATTENTION
Be careful not to damage stationary face of seal (51) with brass rod.	

NOTE: If mechanical seal (51) is not to be replaced, disassembly is complete. Take care to prevent damage to seal components. If mechanical seal (51) is to be replaced, proceed as below.

21. Press stationary part of mechanical seal (51) out of bearing housing (9).

CAUTION	ATTENTION
Be careful not to damage stationary face of seal (51) when pressing it out.	

22. Loosen set screw and remove rotating part of mechanical seal (51) from shaft (6).

CAUTION	ATTENTION
Take great care not to touch or damage the rotating face of the seal (51). This seal face is very sensitive to chipping and/or scratching.	

23. Remove seal spacer (74) from shaft (6) if applicable.

H. INSPECTION OF PARTS

1. BALL BEARING – Ball bearings should be free turning and quiet. Their grease should have a soft consistency and not look or smell burned.
2. GEAR FACES – Some light scratching is acceptable, but if there is any scoring, the part should be replaced. These faces cannot be ground to remove a heavy score mark because their width is critical to performance of pump. Grinding more than several ten thousandths of an inch will cause low capacity. If the face is not flat, pump seizure could occur.

NOTE: Rework other than light stoning or cleaning of gears or gear housings is not recommended. New gear housings are provided with sleeve bearing factory installed.
3. RING GEAR OD – Light scratching and polishing is acceptable. If scoring is present, ring gear should be replaced.
4. HOUSING
 - a. Faces – Some light scratching is acceptable, but if there is any scoring, the part should be replaced.
 - b. Crescent – This piece should be checked for gouges or scoring. If the marking is severe, housing should be replaced.
 - c. ID – If any scoring is present, housing should be replaced.
5. SHAFT – Check shaft for wear, particularly areas where lip seals and bushings are located when pump is assembled. Any heavy wear is cause for shaft replacement. Check edges of keyways for cracks, chipping or rounding. If any of these exists, shaft should be replaced.
6. SLEEVE BEARING – If scoring or heavy polishing is present, bearing must be pressed out of housing, replaced and sized (see machining instruction on next page).
7. FRONT COVER – If faces are scored or heavily scratched, they must be machined per machining instructions. Check ball bearing seating area in front cover after severe ball bearing failure. If ball bearing seating OD is badly scored, deburr it before pump assembly.
8. LIP SEAL – If seal edge is flat or damaged or elastomer is deteriorated, replace lip seals.
9. MECHANICAL SEAL – If either the carbon or tungsten carbide faces of the mechanical seal are heavily scratched, scored or blistered, the entire mechanical seal must be replaced.

I. MACHINING INSTRUCTIONS

The front cover (1) can usually be restored to as-new condition by machining damaged faces. Sleeve bushings (53) usually require replacement when cover is machined.

To repair damage to face of front cover (Figure 2 on next page) and to replace sleeve bushings (C) proceed as follows:

1. Press out sleeve bushing (53), (54) from front or intermediate covers.

NOTE: If pump is equipped with bronze bearing, consult factory.
2. Place front cover in a lathe and indicate face (A) and counterbore (B) square and concentric with respect to bore C within .0008 inch TIR.
3. Machine face (A) deep enough to remove any scored material. Ensure that face is flat within .0008 inch TIR with a 32 microinch finish.

CAUTION

ATTENTION

Being out of flat in excess of .0008" can cause pump failure.

- NOTE: If more than .015" is machined (removed) from face (A, Figure 2), the same amount should be machined (removed) from G and F, Figure 2.
4. Press sleeve bushing (53), (54) in from front cover or intermediate cover ensuring that split in bushing (53), (54) is positioned as shown in Figure 2.
 5. Fabricate a bushing sizing tool as shown in Figure 3. Press sizing tool through bushing from same direction bushing was originally installed to properly size bushing bore.

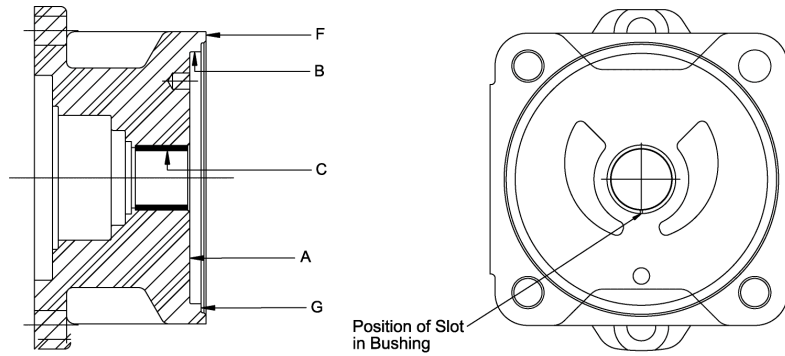
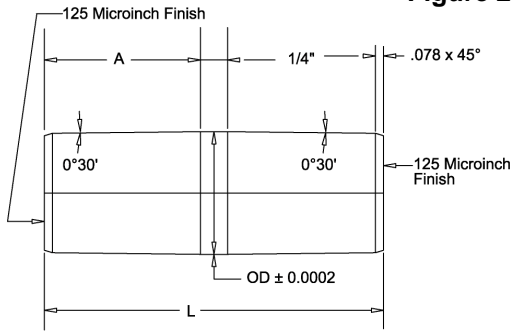

Figure 2 – Front Cover



Case Hardened HRc 60-63
Grind or Polish to 8 Microinch Finish

Frame Size	"L" in.	"A" in.	"OD" in.
2	2.284	0.984	0.712
3	2.677	1.181	0.87
4	3.071	1.378	1.1062
5	3.465	1.575	1.382
6	4.252	1.969	1.776
8	5.039	2.362	2.17

Figure 3 – Sleeve Bearing (53) Sizing Tool

J. SPARE PARTS AND KITS

IDP	Qty.	Description	Seal Kit	Shaft Kit	*Round Hsg. & Gear Kit	*Square Hsg. & Gear Kit
1	1	Front Cover				
3	—	Round Housing			X	
4	1	Square Housing				X
6	1	Shaft		X		
8	1	Housing Tube				
9	1	Bearing Housing				
11	—	Pinion Gear			X	X
12	—	Ring Gear			X	X
13	—	Key		X		
15	1	Rear Cover				
31	1	Ball Bearing		X		
32	2	Outside Seal	X			
33	1	Bearing Snap Ring		X		
34	4	Tie Rod Washers				
35	1	Rear Cover O-Ring	X			
36	1	Shaft Key		X		
37	—	Housing Pin				
38	4	Rear Cover Bolts				
39	4	Tie Rod Bolts				
40	1	Front Cover O-Ring	X			
41	—	Housing O-Ring	X			
42	4	Seal Housing Bolts				
51	1	Mechanical Seal	X			
53	—	Sleeve Bushing			X	X
70	1	Seal Housing				
74	1	Seal Spacer				
75	4	Seal Housing Bolts				
80	4	Weep Hole O-Rings				
81	1	Bearing Housing Pin				

* Housings and gears cannot be sold separately since they are matched sets.

Table 1 – Pump Parts List

K. REASSEMBLY OF PUMP

CAUTION	ATTENTION
READ THIS ENTIRE PROCEDURE BEFORE ASSEMBLING PUMP	

NOTE: Inspect all running surfaces for scratching, scoring and wear prior to assembly of pump. Minor scratching is acceptable. If parts are heavily scratched or scored, they should be replaced. Thoroughly clean all pump components.

	WARNING
Follow the suppliers recommendations when using cleaning fluids.	

NOTE: Imo Pump recommends replacement of all "O" rings, lip seals, and ball bearing every time these parts are disturbed from their original installed position. If "O" rings and lip seals are, in general, not to be replaced, they must be thoroughly inspected for nicks, cuts or other damage. If any individual "O" ring or lip seal is damaged, it must be replaced.

CAUTION	ATTENTION
If ball bearing (31) was removed from shaft (6), it <u>must</u> be replaced and lip seal (32) <u>must</u> also be replaced (<u>do not</u> install lip seal until told to do so). (Lip seal (32) is only used on 039_-1 and 046A suffix pumps.)	

NOTE: Refer to "Inspection of Parts" for additional information on part inspection and replacement. Wipe all parts with light lubricating oil to assist in assembly.

NOTE: Prior to assembly, remove all nicks and sharp edges on housings and gears with de-burring stone. Particular attention should be paid to kidney port chamfers in housings, to faces of ring and pinion gears and to areas of housings that were pried apart on disassembly. Avoid excessive breaking of edges at outside diameter of ring gear as this could negatively affect flow rate. When reinstalling gears in housings, be sure gears are installed in housings from which they were removed and face direction from which they were removed.

Refer To Assembly Drawing 1 For One Stage (X1, X2) Pumps

Refer To Assembly Drawing 2 For Multi-Stage (X3, X4, X5, X6) Pumps

NOTE: If 'shaft/bearing housing' assembly was not taken apart during disassembly procedure, proceed to step 11.

CAUTION	ATTENTION
Handle 'shaft/bearing housing' assembly with great care during pump assembly, since any significant cocking of bearing housing assembly relative to shaft (6) could damage ball bearing (31) or mechanical seal (51). If shaft (6) is to be set horizontally on a work surface, it should not be allowed to rest on bearing housing.	

NOTE: If 'shaft/bearing housing' assembly was taken apart during disassembly procedure, proceed as follows:

1. Install seal spacer (74) onto shaft (6), if applicable.
2. Apply light film of clean lubricating oil onto carbon face of mechanical seal (51) and install seal retainer with carbon face onto shaft (6) by pushing on seal retainer with fingers only. Do not touch seal face with fingers.

CAUTION	ATTENTION
Take extreme care not to touch or damage carbon face of seal or damage O-ring in seal retainer.	

3. Tighten set screws on seal retainer.
4. Apply light film of clean lubricating oil onto stationary part of mechanical seal (51) and press it into bearing housing (9) with fingers. Be sure it seats all the way to bottom of bore in bearing housing (9).

CAUTION	ATTENTION
Take extreme care not to damage seal mating face or O-ring during assembly. Do not touch seal face with any tools. After installation, clean face with solvent and soft, lint free cloth.	

CAUTION	ATTENTION
If seal mating face is not bottomed out in bore of bearing housing (9), seal could be severely damaged.	

5. Install ball bearing (31) into bearing housing (9) by hand. It should slide in easily. If ball bearing (31) has one shield only, the shield must be facing inside of bearing housing (9).
6. Install bearing retainer plate (70) and capscrews (75). **Do not install lip seal (32) into bearing retainer plate (70) at this point** (lip seal only required for 039_-1 and 046A suffix pumps).
NOTE: If lip seal (32) is already installed in retainer plate (70), remove it and discard.
7. Set shaft (6), which has seal spacer (74) and rotating part of seal (51) already installed, on arbor press. Coupling end must be facing up.
8. Carefully slide bearing housing (9), which has ball bearing (31), seal head and bearing retainer (70) already installed, onto coupling end of shaft (6) until inner race of ball bearing (31) contacts shaft (6).

CAUTION	ATTENTION
Take extreme care not to nick or otherwise damage carbon face of seal (51) when sliding on bearing housing (9).	

9. Press bearing (31) onto shaft (6) until it bottoms on shaft (6) shoulder. Use cylindrical sleeve which contacts only the inner ring of ball bearing (31) and clears inner diameter of bearing retainer plate (70). Snap ring groove in shaft (6) should just clear ball bearing (31) inner ring.
10. Install snap ring (33) on shaft (6).

CAUTION	ATTENTION
Handle 'shaft/bearing housing' assembly with great care for remainder of pump assembly since any significant cocking of bearing housing assembly relative to shaft could damage ball bearing (31) or mechanical seal (51). If shaft (6) is to be set on a work surface, it should not be allowed to rest on bearing housing.	

11. Install three 0-rings (80) into bearing housing (9). If necessary, use grease to hold 0-rings in place.
12. Install 0-ring (40) into bearing housing (9). If necessary, use grease to hold 0-ring in place.
13. Slide shaft/bearing housing (9) assembly, which includes stationary part of mechanical seal (51), ball bearing (31) and ball bearing cover (70), into front cover (1).
14. Remove capscrews (75) and bearing retainer plate (70).

CAUTION	ATTENTION
Do not allow shaft (6) to move axially in front cover (1) as this could cause seal damage.	

15. Secure bearing housing (9) to front cover (1) with cap screws (42). Tighten capscrews with torque wrench per assembly drawing torque values.
16. Install lip seal (32) into bearing retainer (70), where applicable (039_-1, and 046A suffix pumps only).

CAUTION	ATTENTION
Be sure to press only on outside diameter of lip seal (32) to avoid damaging it.	

17. Reinstall bearing retainer (70) onto bearing housing (9) with cap screws (75). Tighten capscrews with torque wrench per assembly drawing torque values.
18. Install first stage key (13), chamfer side up, into keyway of shaft (6) and push it up as far possible toward drive end of pump.
NOTE: If key (13) has a step, install key (13) with step facing up and away from front cover (1).

If not, it should be removed and a small step filed in the portion of the key that sticks above shaft keyway to prevent key (13) from touching front cover (1) face.

19. Install first stage pinion gear (11) on shaft (6). Pinion gear (11) should slide freely on shaft (6) and key (13). If not, ensure key (13) is properly installed and shaft (6) and pinion (11) keyway are free of burrs. Ensure pinion (11) is installed in stage from which it was removed and is facing direction from which it was removed.

CAUTION	ATTENTION
If gears are installed in wrong housing, pump may not perform properly or may seize during operation. This is because gears are matched to each housing individually and may not have correct clearances if installed in another housing. If gears are installed facing wrong direction, pump may not perform properly or may seize during operation. This is because some gears have chamfers on only one side. These chamfers must be positioned facing inside of housing so that there will be no interference with housing radii.	

20. Install ring gear (12) in first stage gear housing (3), or (4) if single stage (X1, X2) pump. Ensure ring gear (12) is installed in stage from which it was removed and is facing direction from which it was removed, if pump has more than one stage.

CAUTION

ATTENTION

If gears are installed in wrong housing, pump may not perform properly or may seize during operation. This is because gears are matched to each housing individually and may not have correct clearances if installed in another housing. If gears are installed facing wrong direction, pump may not perform properly or may seize during operation. This is because some gears have chamfers on only one side. These chamfers must be positioned facing inside of housing so that there will be no interference with housing radii.

21. Install O-ring (41) on first stage square gear housing (4) if single pump, or round gear housing (3) if multistage pump.
22. Install dowel pin (37) in front cover (1).
23. Install first stage gear housing (3), or (4) if single stage pump, with installed ring gear (12), onto shaft (6). Ensure dowel pin (37) engages dowel pin hole in front cover (1) and pinion gear (11) installed on shaft (6) is properly positioned to enter gear housing.

NOTE: If pump is single stage model, proceed to step 39 to complete assembly. If multiple stage pump, continue below with step 24.

24. Install O-ring (41) on back of first stage gear housing (3).
25. Install housing tube (8) on back of first stage gear housing (3).
26. Install second stage key (13), chamfer side up, into keyway of shaft (6).

NOTE: If key (13) has a step, install key (13) with step facing up and away from back face of previous stage.

CAUTION

ATTENTION

When key (13) is installed and pushed up toward drive end, there must be a .020" gap between it and back face of previous stage. If not, be sure the previous stage is seated completely up into housing tube (8). If key (13) is still up against back face of previous stage, it should be removed and a small step filed in the portion of the key that sticks above shaft keyway, to prevent key (13) from touching back face of previous stage.

27. Install second stage pinion gear (11) on shaft (6). Pinion gear (11) should slide freely on shaft (6) and key (13). If not, ensure key (13) is properly installed and shaft (6) and pinion (11) keyway are free of burrs. Ensure pinion (11) is installed in stage from which it was removed and is facing direction from which it was removed.

CAUTION

ATTENTION

If gears are installed in wrong housing, pump may not perform properly or may seize during operation. This is because gears are matched to each housing individually and may not have correct clearances if installed in another housing. If gears are installed facing wrong direction, pump may not perform properly or may seize during operation. This is because some gears have chamfers on only one side. These chamfers must be positioned facing inside of housing so that there will be no interference with housing radii.

28. Install ring gear (12) in second stage gear housing (3). Ensure ring gear (12) is installed in stage from which it was removed and is facing direction from which it was removed.

CAUTION

ATTENTION

If gears are installed in wrong housing, pump may not perform properly or may seize during operation. This is because gears are matched to each housing individually and may not have correct clearances if installed in another housing. If gears are installed facing wrong direction, pump may not perform properly or may seize during operation. This is because some gears have chamfers on only one side. These chamfers must be positioned facing inside of housing so that there will be no interference with housing radii.

29. Install O-ring (41) on second stage gear housing (3).
30. Install dowel pin (37) on back face of previous stage.
31. Install second stage gear housing (3), with installed ring gear (12), onto shaft (6). Ensure dowel pin (37) engages dowel pin hole in back face of previous stage and pinion gear (11) installed on shaft (6) is properly positioned to enter gear housing (3).
32. Repeat steps 24 through 31 for third and fourth stage gear housings (3), if applicable.

33. Install last stage square gear housing (4) key (13), chamfer side up, into keyway of shaft (6).

NOTE: If key (13) has a step, install key (13) with step facing up and away from back face of previous stage.

CAUTION	ATTENTION
When key (13) is installed and pushed up toward drive end, there must be a .020" gap between it and back face of previous stage. If not, be sure previous stage housing (3) is seated completely up into third stage housing tube (8). If key (13) is still up against back of previous stage housing face (3) it should be removed and a small step filed in the portion of the key (13) that sticks above shaft keyway, to prevent key (13) from touching back face of previous stage.	

34. Install square housing pinion gear (11) on shaft (6). Pinion gear (11) should slide freely on shaft (6) and key (13). If not, ensure key (13) is properly installed and shaft (6) and pinion (11) keyway are free of burrs. Ensure pinion (11) is installed in stage from which it was removed and is facing direction from which it was removed.

CAUTION	ATTENTION
If gears are installed in wrong housing, pump may not perform properly or may seize during operation. This is because gears are matched to each housing individually and may not have correct clearances if installed in another housing. If gears are installed facing wrong direction, pump may not perform properly or may seize during operation. This is because some gears have chamfers on only one side. These chamfers must be positioned facing inside of housing so that there will be no interference with housing radii.	

35. Install ring gear (12) in last stage square gear housing (4). Ensure ring gear (12) is installed in stage from which it was removed and is facing direction from which it was removed.

CAUTION	ATTENTION
If gears are installed in wrong housing, pump may not perform properly or may seize during operation. This is because gears are matched to each housing individually and may not have correct clearances if installed in another housing. If gears are installed facing wrong direction, pump may not perform properly or may seize during operation. This is because some gears have chamfers on only one side. These chamfers must be positioned facing inside of housing so that there will be no interference with housing radii.	

36. Install O-ring (41) on last stage gear housing (4).
37. Install dowel pin (37) in back of previous stage round housing (3).
38. Install last stage square gear housing (4), with installed ring gear (12), onto shaft (6). Ensure dowel pin (37) engages dowel pin hole in back face of previous stage round housing (3) and pinion gear (11) installed on shaft (6) is properly positioned to enter gear housing (4).
39. Install washers (34) on capscrews (39) with chamfer on washers (34) facing head of capscrews (39). Install capscrews (39), with washers (34) installed, and tighten with torque wrench to torque values on assembly drawing. Torque one-half value for all capscrews first, then torque to full specified torque value. Capscrew tightening pattern should be across opposite corners for both half torque and full torque tightening.

CAUTION	ATTENTION
With capscrews (30) torqued to full value, pump shaft must turn freely by hand and without significant internal snagging. Otherwise, unit has not been properly assembled.	

40. Install O-ring (35) into rear cover (15). If necessary, use grease to hold O-ring (35) in place.
41. Install end cover (15) on square gear housing (4) using capscrews (38). Tighten capscrews (39) with torque wrench to torque values on assembly drawing.
42. Install coupling key (36) in keyway of shaft (6).

CAUTION	ATTENTION
Take care not to bump shaft during storage, transportation, or installation of pump into operating system.	

L. TROUBLESHOOTING

For assistance with troubleshooting, see General Instruction Manual CA-1.

"X2" TORQUE TABLE

FRAME SIZE	BOLT SIZE	PUMP MODIFICATION	TORQUE	
			LB FT	N.m
2	M10	W	30 ±2	41
		P		
3	M12	W	60 ±5	81
		P		
4	M16	W	115 ±10	156
		P		
5	M20	W	220 ±15	298
		P		
6	M24	W	435 ±15	590
		P		
8	M30	W	870 ±25	1180
		P		

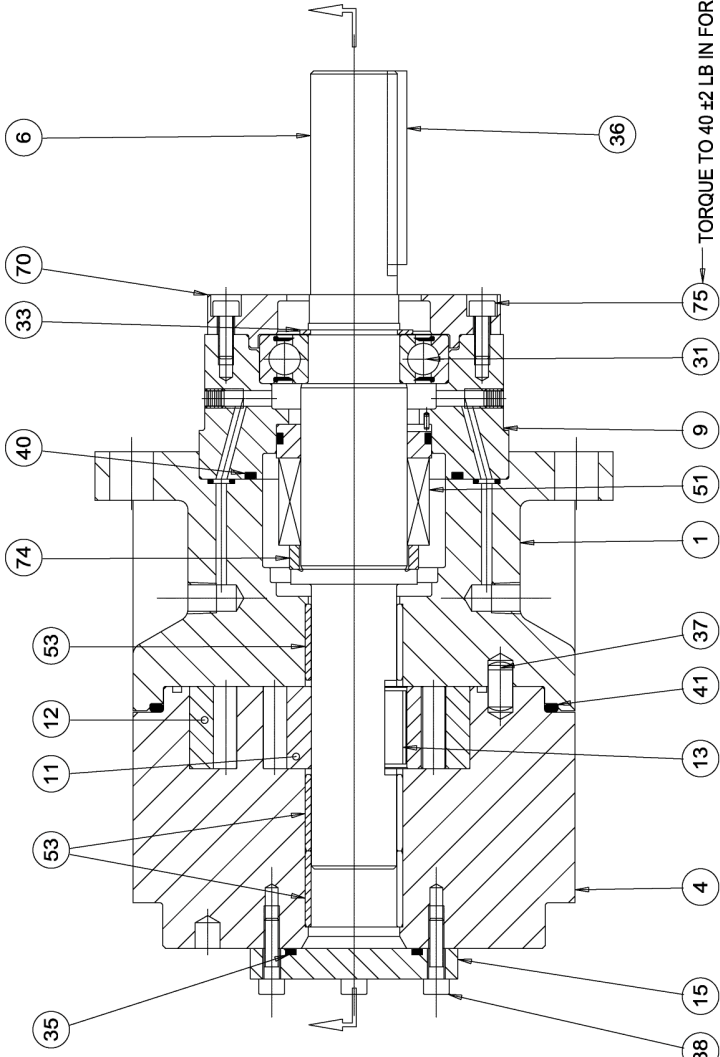

TORQUE TO 40 ±2 LB IN
 TORQUE TO 40 ±2 LB IN FOR SIZES 3, 4 & 5
 TORQUE TO 15 ±2 LB FT FOR SIZE 6

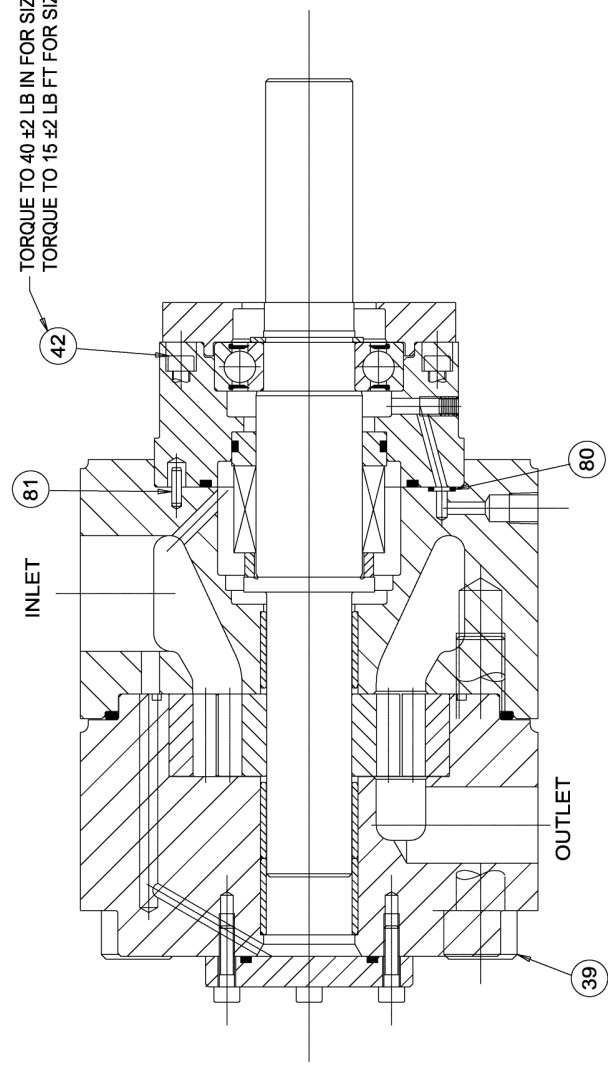

TORQUE TO 40 ±2 LB IN FOR SIZES 3, 4 & 5
 TORQUE TO 15 ±2 LB FT FOR SIZE 6

VIEW WITH TEFLON SEAL

Frame Size	Bolt Size	Pump Mod	"X1 and "X2"		"X3"		"X4"		"X5 and "X6"	
			lb-ft	N.m	lb-ft	N.m	lb-ft	N.m	lb-ft	N.m
2	M10	W	30 ± 2	41	30 ± 2	41	30 ± 2	41	30 ± 2	41
		P	45 ± 2	61	45 ± 2	61	45 ± 2	61	45 ± 2	61
3	M12	W	60 ± 5	81	60 ± 5	81	60 ± 5	81	60 ± 5	81
		P	90 ± 5	122	90 ± 5	122	90 ± 5	122	90 ± 5	122
4	M16	W	115 ± 10	156	115 ± 10	156	115 ± 10	156	115 ± 10	156
		P	175 ± 10	237	175 ± 10	237	175 ± 10	237	175 ± 10	237
5	M20	W	220 ± 15	298	220 ± 15	298	220 ± 15	298	220 ± 15	298
		P	325 ± 15	441	325 ± 15	441	325 ± 15	441	325 ± 15	441
6	M24	W	435 ± 15	590	435 ± 15	590	435 ± 15	590	435 ± 15	590
		P	650 ± 20	881	650 ± 20	881	650 ± 20	881	650 ± 20	881
8	M30	W	870 ± 25	1180	870 ± 25	1180	870 ± 25	1180	870 ± 25	1180
		P	1300 ± 25	1763	1300 ± 25	1763	1300 ± 25	1763	1300 ± 25	1763

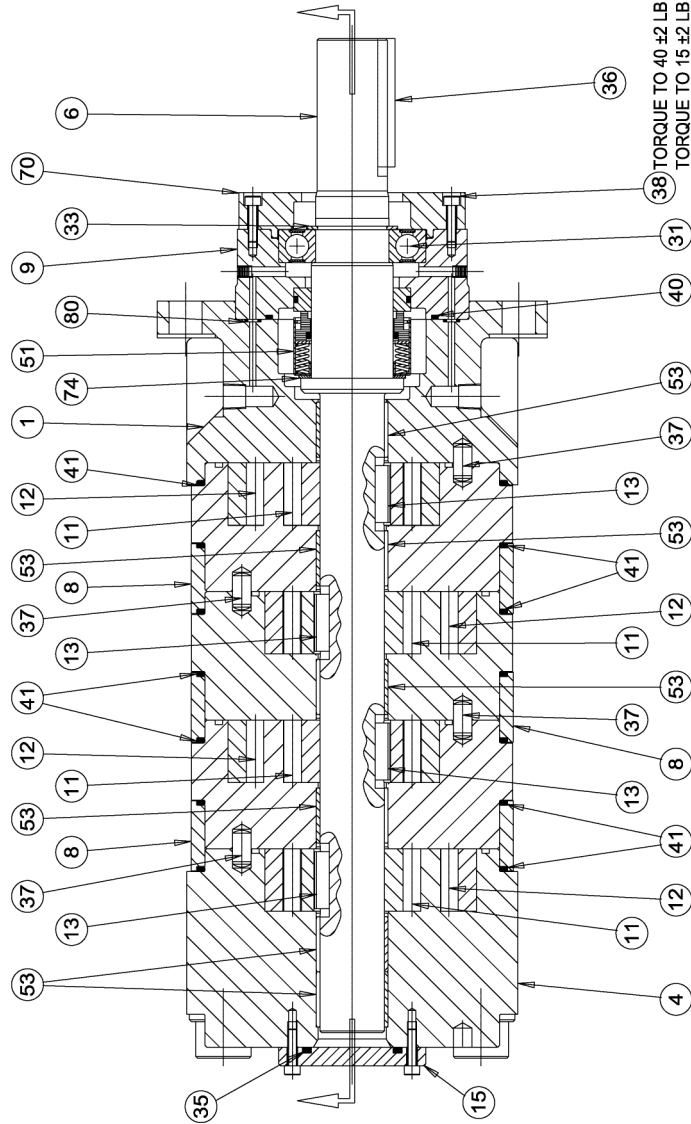

38 TORQUE TO 40 ± 2 LB IN FOR SIZES 3, 4 & 5
 TORQUE TO 15 ± 2 LB FT FOR SIZE 6

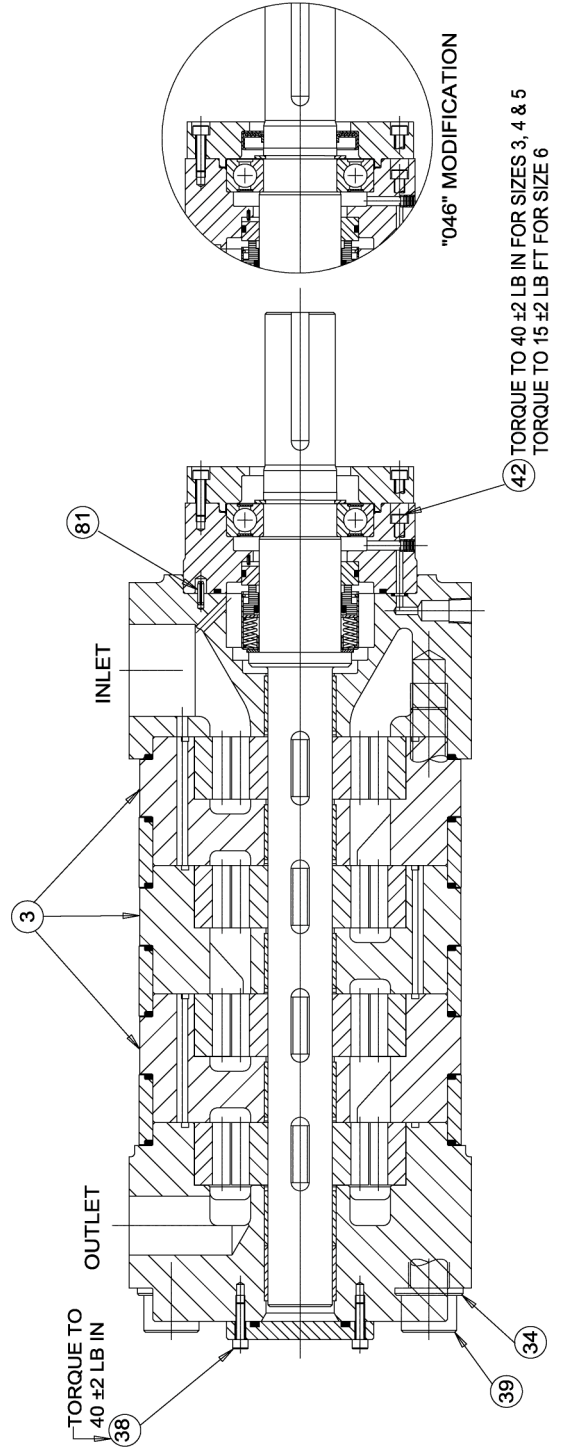

"046" MODIFICATION

42 TORQUE TO 40 ± 2 LB IN FOR SIZES 3, 4 & 5
 TORQUE TO 15 ± 2 LB FT FOR SIZE 6



ALLWEILER



HOUTTUIN



IMO PUMP



WARREN



C

P



A Member of the
COLFAX PUMP GROUP

Imo Pump

1710 Airport Road

PO Box 5020

Monroe, NC

28111.5020

USA

tel +1 (704) 289 6511

fax +1 (704) 289 9273

E-mail

Imo.Pump@ColfaxCorp.com

Internet

<http://www.imo-pump.com>



Quality Management System