



#66209324 | © Wolfgang Jantschoff - Fotolia.com

Karlsruhe - Fotolia.com

CIRCOR | ALLWEILER®

www.circorpt.com

COMMERCIAL MARINE DEFENSE OIL & GAS **POWER & INDUSTRY** RELIABILITY SERVICES

CHEMICAL PROCESSING

GLOBAL SOLUTIONS

CIRCOR | ALLWEILER®

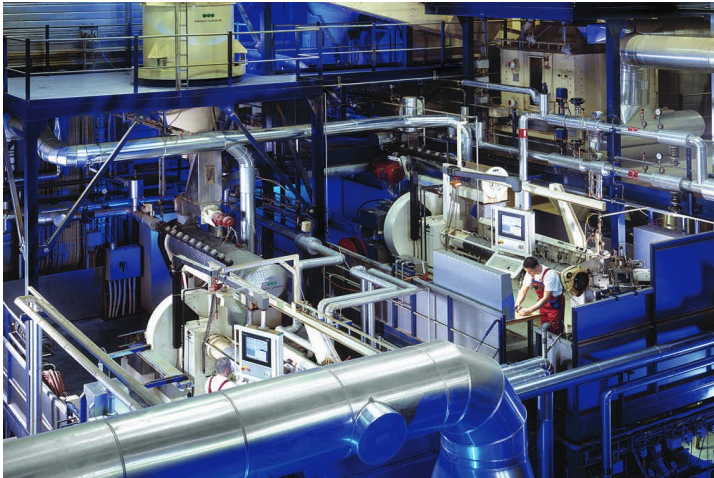

REDEFINING WHAT'S POSSIBLE FOR PROCESS ENGINEERING

CIRCOR is redefining what is possible in the realm of applications for process engineering and the chemical industry. This is particularly true when toxic, volatile, explosive, or other environmentally-harmful liquids must be pumped. In these situations, every drop counts, because even small leaks can lead to significant harm. We collaborate with engineers and plant operators like you in order to find the best possible solutions for handling these types of liquids. With its various process pumps and magnetically-coupled pumps, CIRCOR opens up new opportunities for handling these liquids.

Pumps from CIRCOR uniquely combine decades of continuous practical developments with cutting-edge technologies and materials. The results are extraordinary operational reliability and a long service life.

Collaborate with CIRCOR to overcome your greatest challenges and you will receive more than just a proven and standardized product. You will benefit from 150 years of application experience, reliable technology that is proven in countless plants around the world, and a team of product and service specialists who will maximize the efficiency of your systems from start to finish. Every project is based on a portfolio of pumps, systems, and solutions from brands that you know and trust: Allweiler®, Houttuin™, Imo®, and Warren®. That way, you are assured of receiving reliable solutions that are ideal for your daily requirements. You can also rely on qualified support from industry experts during design, startup, and ongoing operations.

As your global partner we act as a single source for all of your needs, reducing the overall cost of your processes and boosting profitability. We call this Total Savings of Ownership (TSO).

SOLUTIONS YOU CAN COUNT ON

RELIABILITY AND UPTIME

Pumps designed for use in process engineering use material combinations that are precisely matched to your requirements and the liquids in your chemical processes. Magnetically-coupled pumps are hermetically sealed and eliminate all leaks and environmental contamination. With these pumps, you are ready to move explosive, volatile, and toxic liquids without a second thought about harmful emissions. The same applies to liquids that may result in an odor nuisance or environmental contamination. You can even pump chemically aggressive liquids, very hot liquids, and even low-viscosity liquids, with or without solids, safely and efficiently. Since magnetic couplings are wear-free, you will spend less on maintenance, spare parts, and energy.

CIRCOR provides highly efficient solutions for the most demanding and critical chemical processes. These include:

- Feeding reaction vessels
- Brine solutions
- Industrial wastewater
- Metering of chemicals
- Alkaline solutions
- Solvents and absorption liquids
- Process Support
- Organic/inorganic materials
- Heat carrier liquids
- Extrusion
- Cleaning liquids
- Explosive liquids

Pumped liquid	Pump type
	Centrifugal pumps
	Propeller pumps
	Progressing cavity pumps
	Peristaltic pumps
	Three screw pumps
	Two screw pumps
	Gear pumps

Aggressive/non aggressive, contaminated/uncontaminated	●
As above and/or toxic, highly volatile, explosive, harmful to the environment	●
Hot water	●
Heat transfer oils	●
Non aggressive, loaded with solids, with short fibers	●
Non aggressive, contaminated or uncontaminated	●
Aggressive/non aggressive, viscous, with solid contents	●
Aggressive/non aggressive, highly viscous, with fibers and solid contents	● ●
Non aggressive, lubricating viscous	● ● ●
As above and toxic, harmful to the environment	● ● ●
Non lubricating, abrasive, corrosive	● ● ●

Virtually every major company in the chemical industry already uses solutions from CIRCOR:

- BASF
- Dow
- Hitachi
- Recticel
- BAYER
- Dupont
- JinLun
- Rieker-Obov
- BP
- Elastogran
- John Deere
- Shell
- Cannon
- Eternal
- Keil
- Sitara
- China Blue Chemical
- Formosa Plastic
- Kingboard
- VPS
- Chung Shun Chemical
- Fresenius
- LCYCLC
- Wolfkantechnik
- CSPC
- Gorenje
- Notedome
- Xianglu
- CPC
- Hanwha
- Otto
- Yuhua Polyester
- Deltapur Spa
- Hennecke
- Poran

Power & Industry Products & Services

ALLWEILER® HOUTTUIN™ IMO® WARREN® ZENITH®

ALLMAG® SERIES CMA: HERMETICALLY SEALED

THE ALL-ROUND PUMP WITH AN OUTSTANDING PRICE/PERFORMANCE VALUE

ALLMAG® pumps are emissions-free and uniquely combine the benefits of continual, practical development with cutting-edge technology and materials. The results are very high operational reliability and a long service life. An innovative design eliminates conventional wearing parts, simultaneously reducing maintenance requirements and spare parts costs. Connection dimensions comply with DIN EN ISO 2858 for straightforward integration into existing systems. This pump is ideal for the safe pumping of chemicals; thermal oils; environmentally-hazardous, toxic, and slightly volatile liquids; as well as liquids with the potential for creating an odor nuisance.

YOUR BENEFITS:

Economical

A small number of standardized components ensures low storage requirements and economical spare parts management.

Operational reliability

Minimal axial and radial loads and optimal distribution of forces to the bearing with a large SiC bearing and symmetrical impeller.

Maintenance-free

Hydrodynamic lubrication of the bearing results in a virtually unlimited service life, even with low-viscosity liquids; bearing in patented tolerance rings.

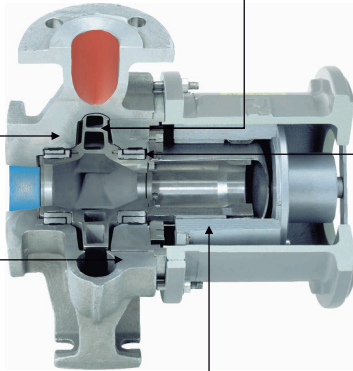

ALLMAG® CMA:
Patented pump concept for difficult liquids; block design; horizontal or vertical installation.

Wear-resistant

High tolerance for solids plus security against leaks and separating can damage thanks to patented rinse flow guidance through the SiC plain bearing. The shaftless design produces a short, straight flow line that eliminates dead spaces and deposits.

Reliable

The short flowline optimizes cooling of the bearing and containment can. The temperature of the cooling liquid rises very little.

Robust

The special casing design with a robust bracket permits disturbance-free absorption of pipeline forces and makes the pump insensitive to external influences.

ALLCHEM® SERIES CNH-B: PROVEN STANDARD PUMPS

CUSTOM SOLUTIONS BASED ON THE SUCCESSFUL STANDARD

Horizontal, single-stage, single flow volute centrifugal pump according to DIN EN ISO 2858 for pumping non-aggressive or aggressive liquids, cold or hot liquids, clean liquids or laden with solids, even viscous liquids. The pump additionally complies with the technical requirements of EN ISO 5199. The series utilizes a modular design in order to maximize use of uniform structural components. The pump is equipped with a highly torsion-proof shaft. This flexural rigidity and the short distance between the pump-side bearing and the shaft seal results in a very true running shaft and optimal conditions for the shaft seal. The shaft is fully protected from liquid contact with seals on both sides of the shaft sleeve and a sealed impeller nut, creating a "dry shaft".

YOUR BENEFITS:

High efficiency

Optimized hydraulic components with very high efficiency and NPSH values. Performance and size according to DIN EN ISO 2858/ISO 5199.

Versatile

Suitable for various flange standards, versatile use of materials, seals, heating, etc.

Maintenance-free

Lifetime grease-lubricated groove ball bearing or an easy-to-maintain oil-lubricated version with constant level oiler.

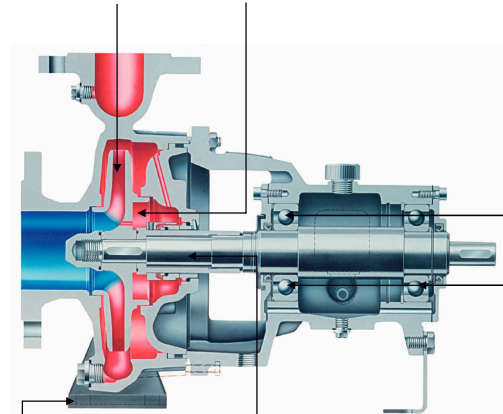

Very economical

Lower stock keeping costs for spare parts and short delivery times thanks to the modular design.

Long-term reliability

The highly torsion-proof shaft system ensures that shaft deflection at the shaft seal lies below 0,05 mm/0,002 inches across the entire operating range, even at 60-Hz speeds. This feature makes the shaft seal extremely reliable.

Long service life

A standard robust bearing design gives the bearing a service life of at least 25,000 operating hours.

Power & Industry Products & Services

ALLWEILER® HOUTTUN™ IMO® WARREN® ZENITH®

ALLHEAT®: INNOVATIVE DESIGN FOR A UNIVERSAL SOLUTION

BEARING AND SEALING CONCEPT DESIGNED ESPECIALLY FOR LOW-VISCOSITY LIQUIDS

The ALLHEAT® series gives you access to centrifugal pumps that are designed from the start for high-temperature applications with heat carriers like thermal oils and hot water. The special design permits pumping of very low viscosity and poorly lubricating liquids. The pumps offer unparalleled versatility, without external cooling, and are uniquely durable in continuous operation. Choose from six different versions: Coupling, block, and in-line versions, each with two pressure levels (for PN16 and pump dimensions according to EN 733 or for PN 25 and dimensions according to DIN EN ISO 2858). Available bearing/seal combinations include an unbalanced all-around mechanical seal with a carbon antimony bearing and a balanced heavy-duty seal with a silicon carbide plain bearing. A safety gland packing, minimized axial thrust, an anti-friction bearing with a long service life, optional quenching of the seal, and a double cardanic coupling for special applications provide additional safety for heat-carrier applications that are frequently critical.

YOUR BENEFITS:

Pressure-safety

Casing parts constructed from ductile iron for high operational reliability.



Efficient

Hydraulically optimized impellers result in very high efficiency; hydraulically balanced impellers minimize axial thrust on the shaft bearing.

Operational reliability

Safety gland packing with a downstream throttle and cooling zone provide additional safety.

Extraordinary reliability

Solid liquid-lubricated plain bearing; low temperatures prevent vaporization of the pumped liquid in the bearing; high load-bearing capacity, long service life; choose between SS1C/SS1C or carbon/steel.

Stability and durability

Unrivalled mechanical strength and stiffness resulting from optimally arranged stiffening ribs, a large centering diameter, and an optimized angle.

Low maintenance

Patented large-dimension seal space to avoid gas-bubble rotation and partial dry running of the mechanical seal.

Long service life

A torsion-proof, robust pump shaft provides for functionally secure alignment of the bearing and shaft seal.

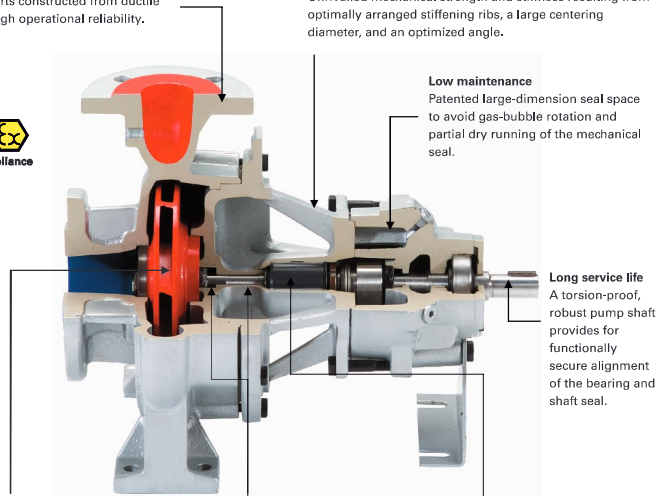

ALLPRO® PROPELLER PUMPS: FOR MAXIMUM CAPACITY

ACHIEVE HIGH FLOW RATES ECONOMICALLY DRY-MOUNTED PUMPS WITH STANDARD MOTORS

With a variety of available materials and shaft seals, our propeller pumps adjust to your pumped liquid. A variety of available propellers, pump designs, and drive types ensure optimal adaptation to operating conditions and performance requirements.

Propeller pumps are used primarily for recirculation or acceleration of aggressive liquids, viscous liquids, and/or liquids laden with solids in reactor circuits, crystallization systems, and vaporization systems.

YOUR BENEFITS:

Variability

A variety of propeller types permit adaptation to operating conditions.

Efficient

Pipe-bend casing with a large, low-loss radius and without disturbing edges in the shaft outlet.

Operational reliability

A highly torsion-proof shaft, adjustable bearing produces a very true-running shaft, creating optimal conditions for the shaft seal.

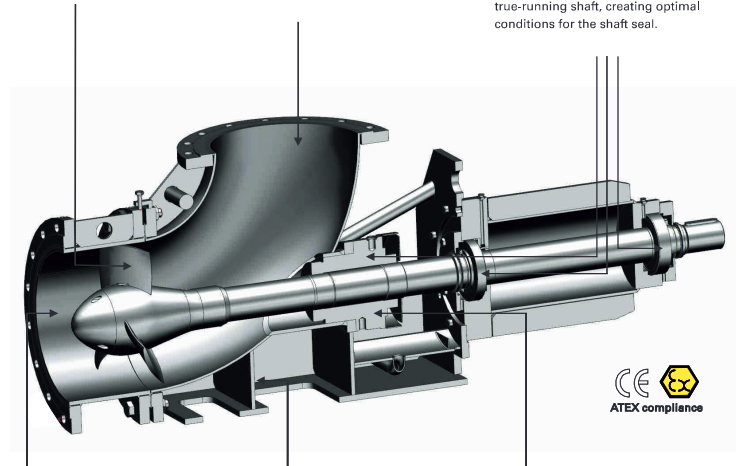

Economical

Intermediate piece is exchangeable when pumping of abrasive liquids causes wear.

Insensitive

An optimized pump design according to the finite element method reduces sensitivity to deformation caused by pipeline forces.

Flexible

Wide a variety of shaft seals (gland packing, mechanical seal, cartridge seal) in different versions and materials.



Power & Industry Products & Services

ALLWEILER® HOUTTUN™ IMO® WARREN® ZENITH®

SN-MB SERIES: PUMP DIFFICULT LIQUIDS SAFELY

PUMP WITHOUT ENVIRONMENTAL RISK

Self-priming, three-screw pumps without shaft seal, with magnetic drive. Magnetically-coupled pumps are hermetically sealed. This ensures that they are 100% leak-free without environmental risks. Use this technology to pump oil and oil products, lightly volatile or toxic liquids, and liquids with a high odor nuisance potential, without any emissions whatsoever.

Choose the SN-MB series for extraordinarily reliable pumps. These pumps combine decades of continuous, practical development with cutting-edge technology and materials. This means very high operational reliability and a long service life. Magnetic coupling eliminates conventional wearing parts, simultaneously reducing maintenance requirements and spare parts costs. The results are large operational savings (high Total Savings of Ownership or TSO). The pump can be used horizontally or vertically, with or without an overpressure valve (add-on or installed in the lines).

YOUR BENEFITS:

Safety

An add-on overpressure valve protects from overloads.

Flexible

Exchangeable casing insert makes it easy to adapt materials to special operating conditions.

Optimized for low wear

Balance pistons at the screws compensate axial thrust.

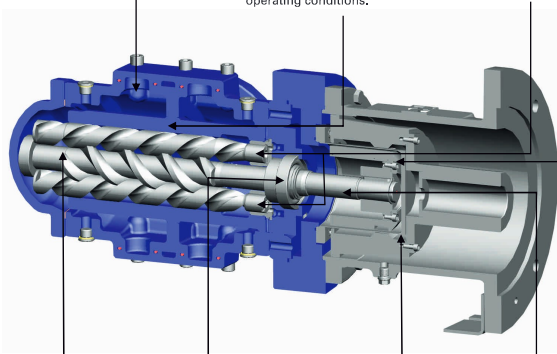

High TSO (Total Savings of Ownership)
Completely maintenance-free magnetic-coupling design.

Long service life

Thanks to hardened and polished spindles.

Extraordinary reliability

Oversized liquid-lubricated groove ball bearing for axial fixation of the drive screw. Optional versions for low-viscosity and/or poorly lubricating liquids.

Overload safe

Samarium-cobalt magnets will not de-magnetize when overloaded (no slip through).

High efficiency

Internal circulation flow optimizes cooling and lubrication of magnetic parts.

TWO-SCREW PUMPS: FOR LOW NPSH VALUES

SUITABLE FOR DRY-RUNNING, TOLERATES SOLIDS

Two-screw pumps employ two intermeshed spindles that are synchronized by several external gears. Their pumping principles are based on the no-contact design of displacement pumps. In other words, a combination of gears prevents contact of the screws. Radial ball bearings that align the screws in their bearings allow these pumps to exceed the performance of other displacement pumps.

Since the surfaces do not contact each other and a lubricating liquid film is not required, two-screw pumps can be manufactured from many different materials. Regardless of whether the liquids have very low or very high viscosity or contain gas, contaminants, or other corrosive materials, two-screw pumps move normal as well as very special liquids with equal reliability and can also be operated across a wide speed range.

This technology is particularly well-suited for industries that work with non-Newtonian or sheer-sensitive liquids or liquids that have a high vapor pressure or fluctuating viscosity and whose processes necessitate flushing with solvents, heating, batch processing, or purging.

YOUR BENEFITS:

High-performance

High suction performance thanks to good sealing of intermeshing screw profiles.

Tolerance for solids

Insensitive to contaminants because there is no metallic contact between the screws and the casing bore.

Long maintenance intervals

Precision gears prevent spindle contact and wear by maintaining a consistent distance between the spindles.

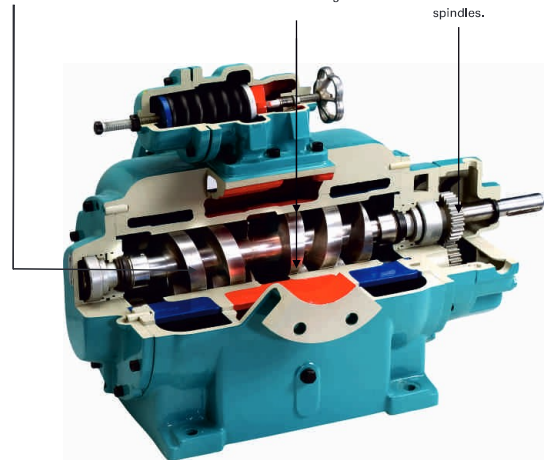

Power & Industry Products & Services

ALLWEILER® HOUTTUIN™ IMO® WARREN® ZENITH®

SERIES ACNBP: PRECISE METERING AT LOW TOTAL COSTS

HIGH PUMPING ACCURACY

These pumps are generally three-stage units. The resulting long sealing line between the rotor and stator enables extraordinarily high metering accuracy. Pumping capacity is up to 42 l/min (11 gpm).

- Ideal for use in laboratories and metering of auxiliary materials
- Available as base-plate or block versions
- Available as CIP/stainless steel version in compliance with the 3-A sanitary standard in the United States

Open product-lubricated, flushable joint or joint encapsulated by liquid-sealed collars available. Sealing achieved by a dead space-free mechanical seal as standard. The shaft seal is arranged in the suction casing so that it lies completely in the flow of pumped liquid. Stators are available in light food-safe material and with varying material qualities, with uniform or non-uniform wall thicknesses. Stators with a uniform elastomer wall thickness achieve lower startup and operating torque even with alternating liquid temperatures; they have a lower power requirement, run quietly, and produce low-pulsation pumping. The pressure casing is horizontal on the underside (asymmetrical). Suction casing with tangential flushing/drainage branch on the underside of the casing. This provides for flawless flushing and draining of the casing.

YOUR BENEFITS:

Long service life and rapid installation

The stator is vulcanized in a stainless steel pipe and provided with threaded connections on both ends. These connections provide a reliable seal to the suction and discharge line while protecting the stator casing from corrosion.

Maintenance-free bearing

The two groove ball bearings are lifetime lubricated. They absorb all radial and axial forces.

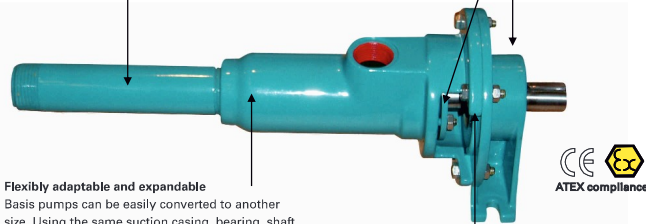

Flexibly adaptable and expandable

Basis pumps can be easily converted to another size. Using the same suction casing, bearing, shaft seal, and universal joint shaft, simply insert or remove the reducing ring (between suction casing and stator) and then exchange the rotor and stator.

Universal in use

The various shaft seals enable adaptation to a variety of operating conditions.

SERIES ALL-OPTIFLOW®: ECONOMICAL, POWERFUL, AND UNIVERSAL

TOTAL COSTS THAT ARE SIGNIFICANTLY LOWER THAN COMPARABLE SYSTEMS

ALL-OPTIFLOW®-progressive cavity pumps generate pressure of up to 6 bar (87 psi) to move virtually any type of liquid (even with fibrous and solid materials) efficiently and reliably. Their capacity is up to twice as high as conventional pumps.

Numerous design details on ALL-OPTIFLOW® not only boost efficiency, they also lower operating and maintenance costs. The service life of ALLDUR® stators can be up to five times as long as stators made from conventional elastomer. In addition, CIRCOR offers a variety of rotor coatings for specific conditions, which can significantly improve your processes.

YOUR BENEFITS:

Low maintenance costs

Patented tolerance-free stub shaft connection, removable bearing bracket and drive shafts that can be relubricated and protected against spray water, and high-quality joints.

Low spare parts costs

Lifetime oil-lubricated joint that is protected against solids and insensitive to overpressure, as well as a long service life through precise adaptation to the liquid with 20 different materials for the stator elastomer.

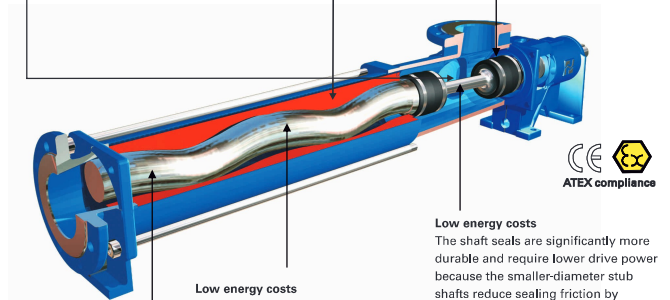

Low energy costs

Innovative single-screw rotor for higher power density. An innovative rotor geometry reduces average sliding speed by 20%, thereby lowering energy consumption and extending the service life of the rotor.

Low energy costs

Special rotor surface minimizes starting and operating torque. A patented process creates a precision-contoured, smooth surface with a structure similar to shark skin. The benefits are optimized flow and sliding properties, while the rotor exhibits much lower adhesion and sliding friction. This results in longer maintenance intervals, lower starting forces, and lower power requirements.

Low energy costs

The shaft seals are significantly more durable and require lower drive power because the smaller-diameter stub shafts reduce sealing friction by approximately 50%.

Power & Industry Products & Services

ALLWEILER® HOUTTUIN™ IMO® WARREN® ZENITH®

ZENITH® GEAR PUMPS: REPEATABLE PRECISION AT HIGH PRESSURE

ZENITH GEAR PUMPS CAN BE FOUND ANYWHERE THAT LIQUIDS MUST BE METERED WITH REPEATABLE PRECISION AND LOW PULSATION

Zenith® pumps and systems are used in a range of applications in a variety of markets. Generally, Zenith® pumps meter chemical solutions; yet the requirements of each generic metering function can be industry specific. Zenith® pumps applications are classified as dosing, filling, injection, coating, extruding, spraying or spinning.

A Zenith® precision metering pump is the pump of choice for accurately controlling the flow of chemical additives. Precision ground and lapped components produce extreme accuracy, linearity and repeatability under varying process conditions. Stainless steel or hardened tool steel offer excellent corrosion and wear resistance. The result is smooth and accurate flow that virtually eliminates over-dispensing, over-spraying, improper blending and improper mixing.

Product quality - The precise, repeatable and pulseless flow of the Zenith® pump ensures accurate and smooth dispensing of chemical additives, thus helping you produce a high-quality paper product. Used in conjunction with a Zenith® ZVD speed control package, pump speed accuracy of 0.1% of base speed can be achieved.

Cost savings - The high efficiency and metering accuracy of the Zenith® pump will enable you to continuously dispense a precise amount of additive and reduce chemical expenses. Eliminating waste and preventing the cost of replacement manufacturing is also a direct savings.

YOUR BENEFITS:

Flexible

The pumps can be directly coupled, with magnetic couplings and as immersion pumps.

Complete

Expensive flow meters, pressure regulators and dampeners are no longer necessary.

Reliable

High-quality materials maximize service times and minimize maintenance downtimes.

Low maintenance

Low maintenance requirements with only three moving parts, low maintenance costs, and rapid completion of maintenance tasks.

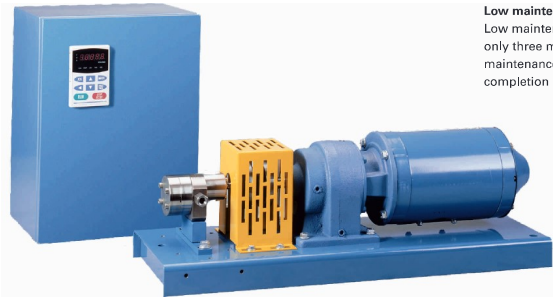

ALLMOVE® SERIES: WHERE OTHERS REACH THEIR LIMITS

PATENTED DETAILS ENSURE DISTURBANCE-FREE OPERATION

Each ALLMOVE® pump is configured at the factory for your specific requirements. Depending on the pumped liquid, the pump hose will be constructed of natural rubber, perbutane, EPDM, or hypalone. ALLMOVE® pumps are self-priming and even pump liquids with large solids without disturbance.

Options for special usage scenarios:

Pulsation dampers

An elastic damper hose changes its chamber volume as pressure changes, thereby balancing out spikes in volume flow and pressure. The pulsation damper protects the pumps and piping. Pulsation is reduced by up to 95%.

Safety devices

A hose-break detector switches the drive off if the pumped liquid enters the pump casing. This eliminates the possibility of damage.

Vacuum support

The vacuum installation can help you achieve extended suction heights of up to 9.5 mWs, rapidly pump high-viscosity liquids, or meter liquids very precisely. In addition, the pump hose will retain its full suction force throughout its entire service life.

YOUR BENEFITS:

Extended availability

The sliding blocks of the one-piece rotor can be adjusted quickly and easily.

Maintenance-free permanent lubrication

Glycerin filling lubricates the hose and all moving parts permanently and effectively.

Only one wearing part

Only the pump hose is subject to wear. It can be exchanged quickly without opening the pump casing.

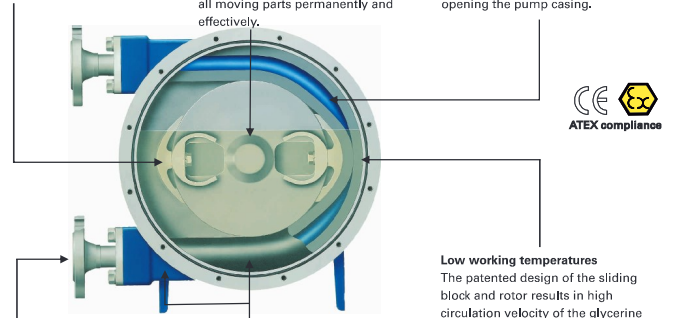

Low working temperatures

The patented design of the sliding block and rotor results in high circulation velocity of the glycerine filling. In conjunction with the low pitch of the sliding block, this results in an unusually low working temperature, which gives the hose a very long service life.

Long hose service life

Patented elastic inclusion of the pump hose; pump hoses in four different elastomer qualities – specially wound, fabric reinforced, and polished. Q_{max} 60 m³/h (264 gpm), max. 16 bar (232 PSIG); max. suction height 9.5 mWs.

Low installation costs

ALLMOVE® is delivered with a flange as standard equipment. Other connections are available.

Power & Industry Products & Services

ALLWEILER® HOUTTUIN™ IMO® WARREN® ZENITH®



THE BEST FLUID HANDLING SYSTEM AT THE CORE OF EVERY CHEMICAL PLANT

Pumps and engineered systems from CIRCOR are the most trusted names in fluid handling applications all over the world. Your CIRCOR team focuses on developing and delivering the best solution for individual requirements, whatever your challenges, wherever they are in the world. We call this "Total Savings of Ownership." Savings from CIRCOR begins with a fair price, but "Total Savings of Ownership" involves an understanding of what it takes to optimize profitability throughout the life of your plant.

Partner with CIRCOR for our deep base of industry knowledge, engineering experience, and application expertise that allows us to optimize system performance while ensuring your team has the knowledge and training it needs. With the tools to simplify your design and engineering processes and the global presence to ensure you have what you need when you need it, we are committed to being a partner in your success by redefining what's possible for you and your customers.

REDEFINING GLOBAL SOLUTIONS

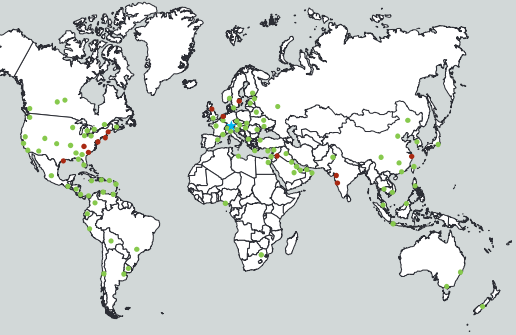

CIRCOR maintains regional engineering and manufacturing facilities to support you around the world and around the clock.

- ★ Global Headquarters
- Regional Manufacturing and Engineering Support Facilities
- Global Distributor Network

CIRCOR

ALLWEILER GmbH
Allweilerstr. 1
78315 Radolfzell
Germany

1710 Airport Road
Monroe, NC 28110
USA

Unit 1803, 18/F
Clifford Centre
778 Cheung Sha Wan Road
Lai Chi Kok, Kowloon
Hong Kong

Unit 804,
Venture International Park
Building B
No. 2679 Hechuan Road
Shanghai 201103
China
Tel. +86 21 6248 1395

Tel. +49 7732 86 0

Tel. +1 704 289 65 11

Tel. +852 3473 2700

www.circorpt.com



Power & Industry Products & Services

ALLWEILER® HOUTTUIN™ IMO® WARREN® ZENITH®

CIRCOR, ALLWEILER, IMO, TUSHACO, ZENITH and WARREN are registered trademarks and HOUTTUIN is a trademark of CIRCOR or its subsidiaries in the U.S. and/or other countries. (c) 2018, CIRCOR. All rights reserved. 488180 - 2018.04