

7 Tips for Choosing a Metering Gear Pump

Take advantage of OEM experience to get your system right from the start.

BY **ROBERT LIMPER & EMMETT SELLERS**
COLFAX FLUID HANDLING

Within the general classification of external gear pumps, precision gear metering pumps are a specialized subset providing accurate, reliable and pulse-free metering performance over a wide range of applications and process fluid conditions.

While many gear pump applications are designed for simple transfer of viscous liquids, others are manufactured with extremely close tolerances, allowing for much higher pressures and the extremely accurate flows required of precision metering type applications. They differ from the pumps used for transfer applications in that internal operating clearances are much tighter, minimizing internal fluid slip and allowing for highly accurate and measured amounts of fluid to be metered and transferred. Due to their extreme close tolerances and smaller gear sizes, these pumps are capable of flows as low as 0.5 cubic centimeters per minute with pressures to 10,000 psi and temperatures from -40 F to 950 F.

In the process industries, nothing could be more mission critical than ensuring the integrity of the process

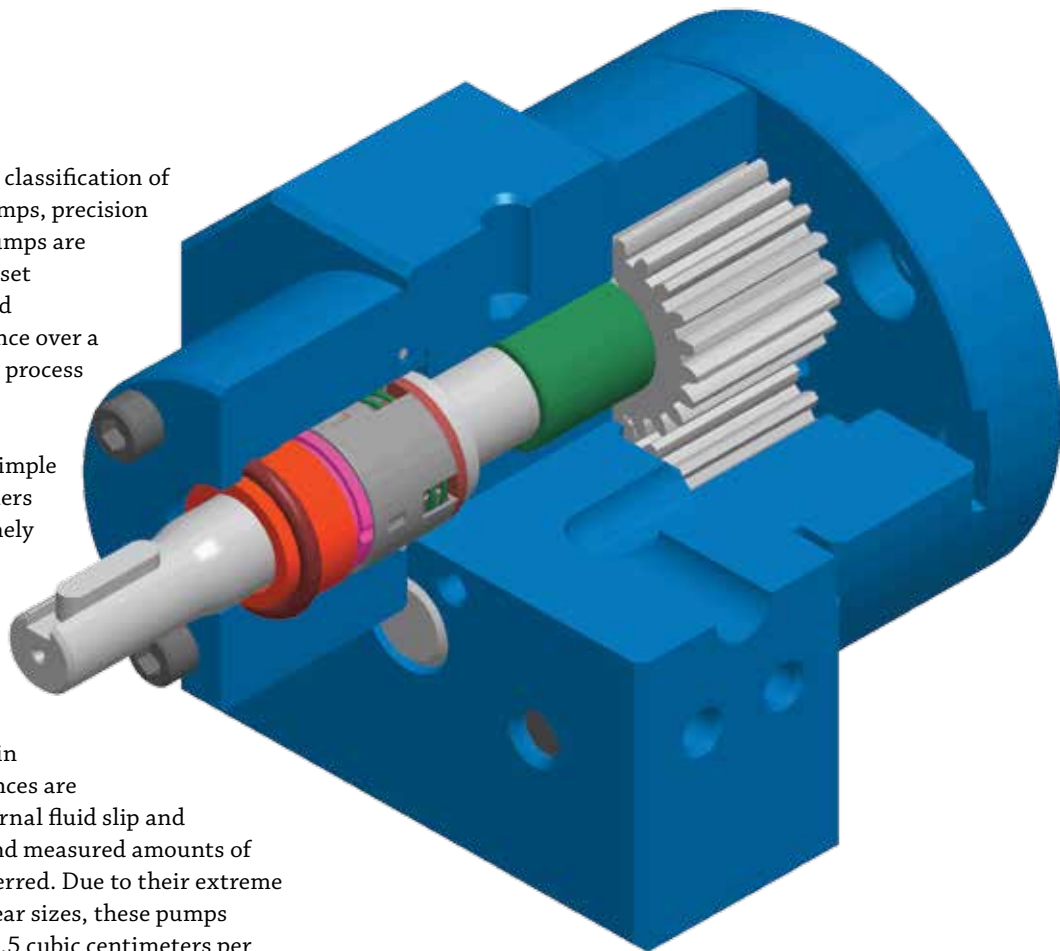

Image 1. A gear metering pump's internal clearances are extremely close – as small as 50 millionths of an inch – ensuring a consistent flow rate and high pressure capabilities. (Images courtesy of Colfax Fluid Handling.)

itself. The pump systems supporting these processes must be uniquely designed and configured to align with that unique process. Close tolerance precision gear metering pumps in metering applications offer accurate delivery, are reliable in service and have virtually pulse-free fluid delivery performance.

Metering, mixing and spray applications that rely on precision gear metering pumps involve chemicals, extruded plastics, fiber spinning, paints, adhesives and sealants, or other additives supporting either a specific process operation or final product.

In these instances, flow variances due to inconsistent and/or pulsating flow can either completely ruin the end product or produce off-spec product, resulting in productivity losses, increased rework and excessive product waste—all with an end result of increased cost to the manufacturer.

Examples of challenges precision gear metering pumps can tackle include:

- overspraying/overdispensing resulting in excessive material waste and increased manufacturing costs

- overfeeding additives to account for under-dosing resulting in extra cost and effect on product appeal
- difficulty controlling extruder variations such as pressure fluctuations, viscosity inconsistencies and density changes
- inefficient pressure and volume variations in paint spray equipment applications, affecting quality and productivity on the line
- overfeeding expensive process chemicals to prevent the under-dosing that would affect the finished product quality

- irregular, pulsating delivery of expensive additives

Gear pumps are engineered to provide high wear resistance and dimensional stability, even under extremes of fluid temperatures, pressures, viscosities and abrasive or corrosive composition. Products with viscosities up to 2 million centipoise (cP) can be accommodated.

Image 3. With very few parts, and only two of those moving, gear metering pumps are easy to maintain.

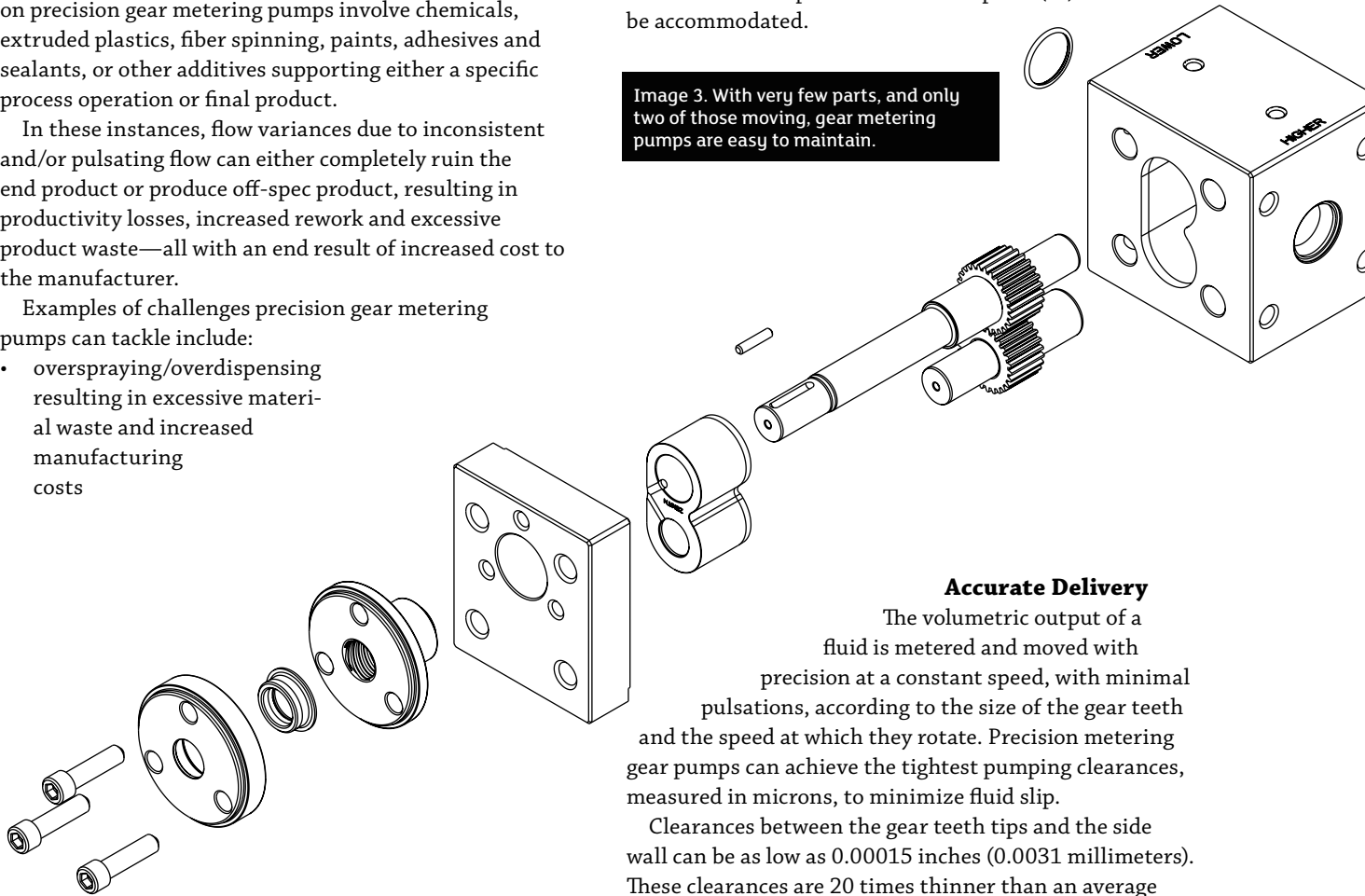

Accurate Delivery

The volumetric output of a fluid is metered and moved with precision at a constant speed, with minimal pulsations, according to the size of the gear teeth and the speed at which they rotate. Precision metering gear pumps can achieve the tightest pumping clearances, measured in microns, to minimize fluid slip.

Clearances between the gear teeth tips and the side wall can be as low as 0.00015 inches (0.0031 millimeters). These clearances are 20 times thinner than an average sheet of paper.

Manufacturing tolerances on many parts to +/- 50 millionths of an inch with surface finishes as smooth as 4 micro inches or better are possible. A continuous, pulseless stream of dispensing or dosing results as the gear pumps move many small cavities per revolution.

Sustained linear flow can be maintained even during changes in operating speeds, pressures and temperatures. The drive system and incorporation of closed loop speed controller can maintain speed accuracy at 0.1 percent levels.

Reliable in Service

Metering gear pumps can be made of many variations of stainless steel for corrosive or sanitary applications,

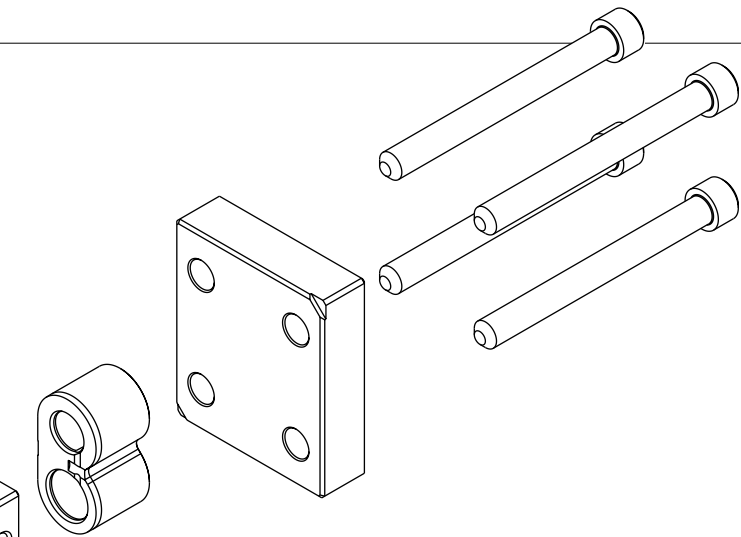

but they are commonly made of hardened tool steel for abrasive applications. Maintenance on a metering gear pump is typically much lower than with other technologies due to the rugged construction and limited number of moving parts. In many cases there are only three moving parts—the drive shaft, the drive gear and the driven gear. Fewer parts means reduced, as well as easier and faster, maintenance.

Conversely, many other metering pump technologies contain as many as 16 moving parts, all subject to wear. In addition, most have check valves that risk failure due to erosion, corrosion or foreign particles caught between the valve ball and seat. Further, these check valves create restrictions increasing the net positive suction head (NPSH) required for the pump.

Should your process require an accurate, reliable metering gear pump, it is important to keep the following tips in mind.

1 Get the application data right.

As with all pump applications, it is imperative to convey correct and complete application data to the pump manufacturer. Doing so will help the pump work correctly and with minimal maintenance. This data should include but not be limited to:

- flow rate (minimum, normal, maximum)
- inlet and discharge pressures (minimum, normal, maximum)
- viscosity
- temperature (minimum, normal, maximum)
- the fluid being handled as well as elastomer and metal preferences if this is not a common liquid
- whether any solids are present, and if so, the percent of solids, the maximum particle size of solids and the hardness of solids
- motor data (phase, hertz, voltage) and the area classification

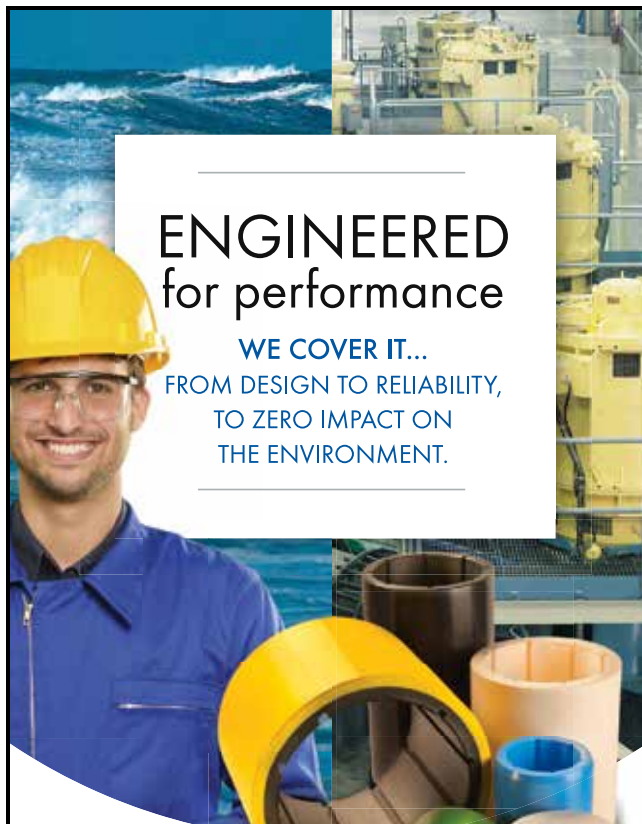

ENGINEERED for performance

WE COVER IT...
FROM DESIGN TO RELIABILITY,
TO ZERO IMPACT ON
THE ENVIRONMENT.

- ThorPlas-Blue
- ThorPlas-White
- Composite
- SXL
- XL
- PT80



Thordon Vertical Pump Bearing Benefits

At Thordon we manufacture high performance, long lasting bearings that require no oil or grease. Our vertical pump bearings have proven performance in various industrial facilities - power plants, water treatment, refineries, mining, agriculture and any industry moving water.

- Abrasion resistance
- Extended wear life
- Dry start up
- Easy to design, machine & install
- ThorPlas-White complies with NSF/ANSI 51, 61 and WRAS approval (UK)

Thordon Bearings Inc. is on the Approved Materials list of top 10 global pump OEMs

THORDON
THORDON BEARINGS INC.

For your local distributor, visit us at www.ThordonBearings.com

Circle 151 on card or visit psfreeinfo.com.

SUMMIT™

Your **Best Value**
in Progressive
Cavity Pumps

SPPC



Gear Joint



Pin Joint



Wobble

Celebrating over 33 years

Call or Email:

920-869-4800

sales@summitpump.com



SUMMIT™ PUMP, Inc

www.SUMMITPUMP.com

BASED IN GREEN BAY, WI

Circle 149 on card or visit psfreeinfo.com.

Maintenance on a metering gear pump is typically lower than with other technologies due to the rugged construction and limited number of moving parts.

2 Convey how you intend to use the pump.

In most cases, the pump manufacturer has seen your application before, or something similar to it, and may have suggestions on designs that may prove to be a better option.

3 Do not let the pump run dry.

Most gear pumps require lubrication to the bearings and seals. Depending on the design

and pumping conditions, these parts can be damaged if run dry for even a short period of time.

4 Ask your supplier if they provide ancillary equipment upstream and downstream that will be necessary or desirable to enhance the performance of your pump.

These items may include strainers, isolation valves, calibration columns and pressure relief valves.



Image 2. Metered flow can be adjusted by simple speed control.

The pump manufacturer is in the better position to identify the mesh size of a strainer, or the proper setting of a pressure relief valve based on the needs of their particular pump.

5 Install a pressure relief valve in the discharge piping from the pump.

Most positive displacement pumps require an external pressure relief valve to be installed in the discharge piping.

Although some pumps may have an internal pressure relief valve, this is typically meant as a secondary precaution to protect the pump, not necessarily the system piping.

Most local codes call for an external pressure relief valve to be installed in the discharge piping if there is the possibility of a restriction in the line such as a plugged nozzle or filter or an isolation valve. Make sure to confirm this and all other applicable codes and requirements.

6 Advise the pump manufacturer if you intend to store the pump for a long period of time before use, or in between uses.

Most manufacturers have a long-term storage plan that may include applying a coat of oil to machined or unpainted surfaces, special packing methods and materials, and even a time schedule for rotation of the motor and pump shaft depending on the anticipated idle time duration.

7 Read and review the manufacturer's installation and operation manual before you install and start the pump.

There is valuable information to be found in these manuals that may prevent catastrophic failures or incorrect installation of the pump.

There are also routine maintenance schedules to keep your pump up and running as well as a troubleshooting guide to assist in diagnosing a problem when it does occur. ■

Robert Limper is director of sales and global product management and **Emmett Sellers, P.E.**, is Business Development Manager for Colfax Fluid Handling, Zenith Pump Division. For more information, visit colfaxfluidhandling.com



EcoFlow
A ThermOmegaTech product

**Minimize
Water Flow
Maximize
Cash Flow**

The EcoFlow Seal Flush thermal relief valve drastically reduces water consumption and costs by automatically and reliably controlling seal water flow and temperature from double mechanical seals.

- Decrease seal water consumption
- Maximize water conservation
- Automatically modulates water flow
- Self-actuating with no external power
- Easy to install
- Fail safe design

EcoFlow Seal Flush modulates open when seal water exceeds the specified factory set point, discharging hot water and displacing it with cool water, all while eliminating the need for user monitoring. It requires a simple installation to reduce water usage, waste water treatment and costs.

Learn more at ThermOmegaTech.com/EcoFlow

ThermOmegaTech

(877) 379-8258

THE WORLD LEADER IN SELF-ACTUATED TEMPERATURE CONTROL SOLUTIONS