



PRODUCT SERVICE MANUAL

FOR

BK12DHz PUMPS



WARNING

This manual, and the GENERAL INSTRUCTION MANUAL SRM00046, should be read thoroughly prior to pump installation, operation or maintenance.

Manual No. SRM00095

Rev 03 (20-0051)

March, 2020



READ ENTIRE PAGE BEFORE PROCEEDING

FOR THE SAFETY OF PERSONNEL AND TO PREVENT DAMAGE TO EQUIPMENT, THE FOLLOWING NOMENCLATURE HAS BEEN USED IN THIS MANUAL:

	DANGER	Failure to observe precautions noted in this box can result in severe bodily injury or loss of life.
---	---------------	--

	WARNING	Failure to observe precautions noted in this box can cause injury to personnel by accidental contact with equipment or liquids. Protection should be provided by user to prevent accidental contact.
---	----------------	--

CAUTION	ATTENTION	Failure to observe precautions noted in this box can cause damage or failure of equipment.
----------------	------------------	--

Non-compliance of safety instructions identified by the following symbol could affect safety for persons:	Safety instructions where electrical safety is involved are identified by:	Safety instructions which shall be considered for reasons of safe operation of the pump and/or protection of the pump itself are marked by the sign:
		ATTENTION

CONTENTS

SAFETY AND TABLE OF CONTENTS	2
A. GENERAL INSTRUCTIONS	3
B. INTRODUCTION.....	3
C. DESCRIPTION OF THE PUMP	3
D. PUMP MODEL IDENTIFICATION	4
E. ORDERING INSTRUCTIONS	4
F. OPERATION	4
G. PARTS LIST	5
H. PUMP MAINTENANCE (Disassembly, Assembly)	6
<i>SEAL DRAWING</i>	10
<i>BOLT TORQUE CHART</i>	11
<i>TROUBLESHOOTING</i>	12
I. FIELD AND FACTORY SERVICE AND PARTS	12
J. ASSEMBLY DRAWING	13-16

ATTENTION
<i>If operation of pump is critical to your business, we strongly recommend you keep a spare pump or major repair kit in stock at all times. As a minimum, a minor repair kit (o-rings, gaskets, shaft seal and bearings) should be kept in stock so pump refurbishment after internal inspection can be accomplished.</i>

A. GENERAL INSTRUCTIONS

Instructions found herein cover disassembly, assembly and parts identification of Series BK12DHz pumps.

NOTE: Individual contracts may have specific provisions that vary from this manual. Should any questions arise which may not be answered by these instructions, refer to General Instructions Manual, SRM00046, provided with your order. For further detailed information and technical assistance please refer to Imo Pump, Technical/Customer Service Department, at (704) 289-6511.

This manual cannot possibly cover every situation connected with installation, operation, inspection, and maintenance of equipment supplied. Every effort was made to prepare text of manual so that engineering and design data is transformed into most easily understood wording. Imo Pump must assume personnel assigned to operate and maintain supplied equipment and apply this instruction manual have sufficient technical knowledge and are experienced to apply sound safety and operational practices which may not be otherwise covered by this manual.

In applications where equipment furnished by Imo Pump is to become part of processing machinery, these instructions should be thoroughly reviewed to ensure proper fit of said equipment into overall plant operational procedures.

	WARNING
If installation, operation and maintenance instructions are not correctly and strictly followed and observed, injury to personnel or serious damage to pump could result. Imo Pump cannot accept responsibility for unsatisfactory performance or damage resulting from failure to comply with instructions.	

B. INTRODUCTION

Instruction manual covers Series BK12DHz Imo pumps. This series of pumps has been designed for use in high pressure fuel oil applications. Model, and design construction of each pump can be identified by designator code on pump nameplate. Definitions of model designators are identified in Figure 1.

C. DESCRIPTION OF EQUIPMENT

BK12DHz Series pumps are positive displacement, rotary screw pumps consisting of precision bored housings that enclose a driven screw (power rotor) and four to eight intermeshing following screws (idler rotors). These screws, when rotating, form a succession of closures or cavities. As they rotate, fluid is moved axially from inlet port to outlet port in a continuous, uniform flow with minimum fluid pulsation and pump noise.

D. PUMP MODEL IDENTIFICATION

This instruction manual covers Imo Series BK12DHz pumps with rotor size 187, 250, 275, 312, 350 and 400. The model of each pump is identified on pump nameplate. Refer to Figure 1 and Table 2 for instructional keys when using this manual.

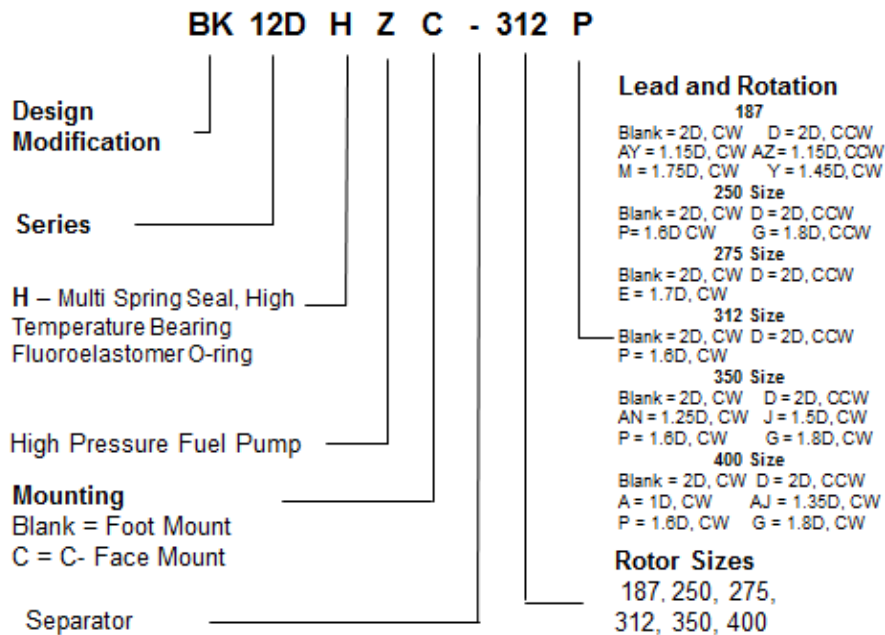

FIGURE 1

E. ORDERING INSTRUCTIONS

When corresponding with Imo Pump regarding Series BK12DHz pumps, refer to pump nameplate, this instruction manual, and assembly drawing as instructed below:

1. From pump nameplate, record the pump model number, serial number and manufactured date.
2. Record instruction manual number, revision and date.
3. From the assembly drawing and/or parts list (table 2) in manual, provide IDP number(s) and names for replacement part(s).
4. Give above information to your Imo service representative.

Imo sales and service representatives are listed herein and in General Instruction Manual, SRM00046.

F. OPERATION

F.1 LIQUID LIMITATIONS

Never operate with thin liquids such as solvents or water. The pump is designed for liquids having general characteristics of oil.

F.2 OPERATING LIMITS

CAUTION	ATTENTION
<p>Operating conditions, such as speed, fluid viscosity, temperature inlet pressure, discharge pressure, filtration, duty cycle, drive type, mounting, etc., are interrelated. Due to these variable conditions, specific application limits may be different from that of operational limitations. Equipment must not be operated without verifying system's operating requirements are within pump's capabilities.</p>	

Under no circumstances are following operating limits (specified in Table 1) to be exceeded without specific approval from Imo Pump.

Table 1 – Normal Pump Operating and Structural Limits

MAXIMUM SPEED	3600 RPM (Depending on Lead)
VISCOSITY	1 cSt Minimum – 3000 SSU (650 cSt) Maximum
MINIMUM – MAXIMUM LIQUID TEMPERATURE	0 to 250 F (-18 to 121 C)
MAXIMUM INLET PRESSURE	150 psig (10.3 Barg)
MAXIMUM DISCHARGE PRESSURE	2200 psig (103.4 Barg) Cont. Duty
FILTRATION	(See General Instruction Manual, SRM00046)
DRIVE	Direct only
MOUNTING	Foot or Flange mounted in any attitude

G. PARTS LIST

Table 2 – Pump Parts List

IDP	QTY	DESCRIPTION	KIT	IDP	QTY	DESCRIPTION	KIT
1	1	Case		46	1	Inboard Cover	
2	1	Inlet Head		47	4	Bearing Retaining Bolt	
3	2	Vent Pin	XX	48	1	Seal Seat Adapter	
4	16	Cover Bolts (8 on 187,250 Size)		49	1	Ball Bearing	X
6	1	Stop Pin		63	1	Power Rotor	XX
7	1	Dyna Seal	XX	66	1	90° Elbow (Not 187 & 250)	
8	2	Housing Retaining Ring	XX	67	2	Pipe Plug (4 on 275)	
9	1	Inlet O-Ring	X	68	1	Nipple (Not on 187 and 250)	
21	2	Suction Idler		69	1	Fitting (Not on 187 and 250)	
22	1	Idler Stop	XX	70	1	Elbow	
23	2	Cups	XX	71	1	Tubing	
24	1	Discharge Housing	XX	73	1	Suction Housing	XX
25	1	Seal	XX	74	1	Elbow (187 & 250 Only)	
26	1	Tube		79	1	Floating BP Bushing	XX
27	4	Tube O-Ring		81	1	Idler Stop Cap Screw	
28	2	Housing O-Ring	X	83	1	Seal Seat O-Ring	X
29	1	Thrust Plate	X	85	1	Pipe Plug (400 Size Only)	
31	1	Key		90	2	Thrust Plate Spacers	
35	2	Discharge Idlers (6 on 312 Size & 2 on 400 size)	XX	91	1	Thrust Plate Bolts	
38	2	Seal Spacer (Not 187, 350 & 400 sizes)		92	1	Thrust Balance Tube	
42	2	Bearing Retaining Ring	X	93	4	Middle Idlers (400 Size Only)	XX
43	1	Bearing Retainer					

X = Minor Repair Kit Items.

XX = Major Repair Kit Items. (Items marked (X) are included in Major Repair Kit).

H. PUMP MAINTENANCE



WARNING

Failure to observe precautions while installing, inspecting and maintaining pump can cause injury to personnel from accidental handling of liquids that may harm skin or clothing, or fire hazard risks from flammable liquids, or injury from high pressure fluid jets.



DANGER

BEFORE working on equipment, make sure all power to equipment is disconnected and locked-out.

H.1 GENERAL COMMENTS

NOTE: Part number identifiers (IDP's) contained within parenthesis such as (10) refer to circled numbers shown on assembly drawings.

H.2 TOOLS REQUIRED

Procedures described in this manual require common mechanics hand tools, a torque wrench, dial indicator and suitable lifting device (such as) slings, straps, etc.

H.3 DISASSEMBLY PROCEDURES

SPECIAL NOTE: To service mechanical seal and ball bearings **ONLY** perform H.3, Steps 1, 6, 7,8 and 9 and H.4, Steps 8, 9, 10 and 11 **ONLY**.



CAUTION

Fluid leakage from disassembly of pump may make floor slippery and cause personal injury.

1. Close suction and discharge piping to pump and remove pipe plug (67) to drain unit. Remove seal piping (71). Remove pump from driver, coupling and base plate. Remove coupling hub and key (31).
2. Remove bolts (4) and inlet head (2). Remove O-ring (9) from inlet head (2).
3. Remove thrust plate (29), and oil balance tube (92) with O-rings (27) by removing hex bolts (91) and thrust spacers (90). Remove O-rings (27) from tube (92).
4. Remove cups (23) from suction idlers (21).
5. Remove suction idlers (21) by unscrewing them from inlet end of pump. Remove remaining idlers (35) from housings (73, 24) by rotating power rotor (63) in a counter-clockwise direction.

CAUTION

Do not permit idlers (21, 93, and 35) to drop as they emerge from housings (73, 24).

6. Remove bolts (47) and bearing retainer (43).
7. Remove assembled power rotor (63). Removal of power rotor (63) includes removal of Truarc rings (42), ball bearing (49), seal seat adapter (48), spacer (38) and mechanical seal (25).

8. Disassemble power rotor (63) as follows: See Figure 1 for seal drawing.
 - a. Using a flat nosed tool, such as a screw driver, remove Truarc rings (42) located on both sides of ball bearing (49) from grooves in power rotor (63).
 - b. Sealed ball bearing is assembled to power rotor (63) with a light press fit. Ball bearing (49) may be removed by using a bearing puller or a vertical arbor press. When using press, two pieces of key stock are to be placed through openings of mechanical seal seat adapter (48) underneath ball bearing (49) on both sides of power rotor shaft. Key stock should be long enough to support power rotor (63) as it is placed in press. Press ram is to be positioned against power rotor (63) coupling end face. Gently press power rotor (63) through ball bearing (49). Ensure power rotor (63) does not fall to floor once ball bearing (49) is off of its diameter.
 - c. Remove seal seat adapter (48) from power rotor (63), then remove mechanical seal stationary seat from seal seat adapter (48). Loosen set screws on mechanical seal rotating assembly body and remove from power rotor (63). Remove spacer (38) from the power rotor (63).
9. Remove O-ring (83) from inboard end cover (46).
10. Remove bolts (4) and inboard cover (46) from case (1).
11. Remove O-ring (28) from inboard cover (46).
12. Remove idler stop (22) from inboard cover (46) by removing bolts (81).
13. Remove floating balance piston (79) from inboard cover (46).
14. Remove stop pin (6) and Dyna seal (7) from case (1).
15. Remove housing snap rings (8) from case (1).
16. Remove housing (24) from case (1) and O-ring (28) from housing (24).

CAUTION

Do not permit housing (24) to drop as it is removed from pump.

17. Remove tube (26) from housing (24 or 73), and O-rings (27) from tube (26).
18. Remove aligning vent pins (3) from housing (24 or 73).
19. Remove housing (73) from case (1).

CAUTION

Do not permit housing (73) to drop as it is removed from pump.

H.4 PUMP ASSEMBLY PROCEDURE

Note: Prior to reassembly of pump, all parts should be cleaned and inspected for nicks and burrs. Replace all worn or damaged parts. Imo Pump recommends replacement of all O-rings (9, 27, 28, 83), Dyna Seal (7), mechanical seal (25) and ball bearing (49) when these parts are disturbed from their previously installed positions. Coat all parts with light lubricating oil to assist in assembly.

Note: Bolts (81) (except for 187 rotor size) have Nylok threads. Torque stated on appropriate assembly drawing for bolt (81) does not include additional torque to install fasteners containing nylok inserts. Torque required for first application is much higher than for subsequent applications. To ensure required preload on Nylok fastener is achieved for each application, the following procedure is mandatory assembly practice.

1. Using a suitable torque wrench, install fastener in mating piece until Nylok insert is completely engaged. Note torque required.
 2. Add torque measured in step 1. to torque value on assembly drawing.
 3. Complete tightening fastener to torque value determined in 2.
1. Install O-ring (28) in groove of discharge housing (24).
 2. Install discharge housing (24) in pump case (1), from suction end of case, aligning groove in housing (24) to stop pin hole in case (1). Install stop pin (6) with Dyna Seal (7) in case (1).
 3. Install O-rings (27) on oil balance tube (26) and oil balance tube (26) in discharge end of inlet housing (73). Install vent pins (3) in same end of inlet housing (73).
 4. Install assembled inlet housing (73) in case (1), ensuring that oil balance tube (26) and vent pins (3) engage holes in discharge housing (24).
 5. Install housing snap rings (8) in case (1).
 6. Install balance piston (79) on inboard cover (46). Install idler stop (22) on inboard cover (46) with cap screws (81). Torque cap screws to proper value for pump size in torque table Figure 2. Install O-ring (28) on inboard cover (46).
 7. Install inboard cover (46) on case (1) using bolts (4). Be sure seal return is facing up. Torque bolts to proper value for pump size in torque table figure 2.
 8. Assemble power rotor (63) and mechanical seal (25) as follows (see seal insert Figure 2).
 - a. Install O-ring in groove of mechanical seal (25) stationary seat. Install mechanical stationary seat in seal spacer (48) ensuring that spring pin is properly positioned to engage slot in seal seat.
 - b. Install spacer (38) on power rotor (63) when required.
 - c. Install mechanical seal (25) rotating assembly on power rotor (63) next to spacer (38). Tighten set screws.
 - d. Wipe mechanical seal rotating and stationary faces with a clean, lint free cloth before assembling faces together.
 - e. Install assembled bearing spacer (48), with stationary seat, to power rotor shaft next to mechanical seal rotating face.
 - f. Install inner Truarc ring (42) in groove of power rotor (63).
 - g. Press bearing (49) on power rotor (63), pressing only on inner race of ball bearing (49) until it is located next to inner Truarc ring (42).
 - h. Install outer Truarc ring (42) in groove of power rotor (63).

9. Install O-ring (83) in seal bore of inboard cover (46).
10. Install assembled power rotor (63) in pump, centering all parts as they enter inboard cover (46). Align one of openings in spacer (48) over drain in inboard cover (46).
11. Install bearing retainer (43) on inboard cover (46) using bolts (47). Torque bolts to proper value for pump size in torque table figure 2.
12. Install idlers (35, 21) into housings by meshing threads with power rotor thread and screwing them into housing idler bores.
13. Install cups (23) to ends of suction idlers (21).
14. Install O-rings (27) on oil balance tube (92) and oil balance tube (92) in inlet housing (73).
15. Install thrust plate (29) to pump case (1) with spacers (90) and thrust plate bolts (91), ensuring that pin hole in thrust plate (29) engages tube (92) in suction housing (73). Torque bolts to proper value for pump size in torque table figure 2.
16. Install O-ring (9) to groove in inlet head (2).
17. Install inlet head (2) using bolts (4). Torque bolts to proper value for pump size in torque table Figure 2.
18. Install seal piping (71) and drain plug (67).

Note: Inlet head (2) can be rotated and repositioned in 90° increments to suit suction piping. To change inlet position, disconnect seal piping (71), remove bolts (4) and rotate inlet head to desired position. Install bolts (4) and Torque bolts to proper value for pump size in torque table figure 2. Reconnect seal piping (71).

19. Install coupling hub key (31). Install and align pump and driver as specified in General Instruction Manual, SRM00046.

H.5 SPECIAL TESTING INSTRUCTIONS

After pump has been reassembled with a major kit, it is recommended that a break-in test be performed to allow idlers to polish into babbitt housing bores. For this test, pump should be run to maximum required working pressure starting from 300 psig (20.7 Barg), in 200 psig (13.8 Barg) increments, holding each pressure for five minutes.

FIGURE 1

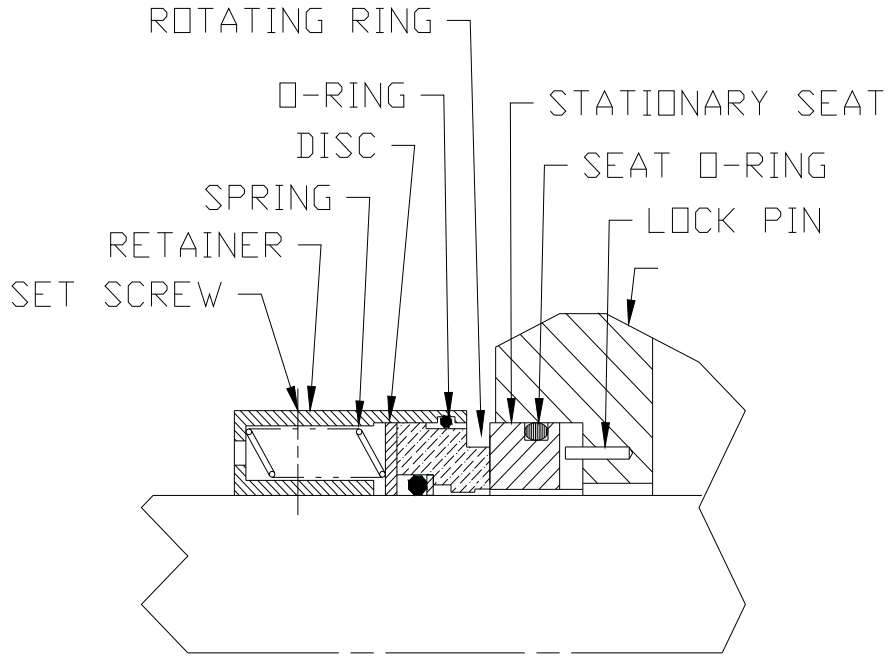

MULTI-SPRING SEAL

Figure 2 – Torque Table

Pump Frame Size	Bolt Description (IDP #)	Torque
187	Inlet Bolt (4)	90 ± 5 Lb-Ft (122 ± 7 N-m)
	Thrust Plate Bolt (91)	130 ± 10 Lb-In (176 ± 13 N-m)
	Inboard Cover Bolt (4 or 93)	90 ± 5 Lb-Ft (122 ± 7 N-m)
	Idler Stop Bolt (81)	27 ± 2 In-Lb (37 ± 3 N-m)
	Bearing Retainer Bolt (47)	130 ± 10 Lb-In (176 ± 13 N-m)
250	Inlet Bolt (4)	160 ± 10 Lb-Ft (217 ± 13 N-m)
	Thrust Plate Bolt (91)	30 ± 2 Lb-Ft (40 ± 3 N-m)
	Inboard Cover Bolt (4 or 93)	250 ± 15 Lb-Ft (340 ± 20 N-m)
	Idler Stop Bolt (81)	65 ± 5 Lb-Ft (88 ± 7 N-m)
	Bearing Retainer Bolt (47)	22 ± 2 Lb-Ft (30 ± 3 N-m)
275	Inlet Bolt (4)	60 ± 5 Lb-Ft (80 ± 7 N-m)
	Thrust Plate Bolt (91)	30 ± 2 Lb-Ft (40 ± 3 N-m)
	Inboard Cover Bolt (4 or 93)	110 ± 10 Lb-Ft (150 ± 13 N-m)
	Idler Stop Bolt (81)	18 ± 2 Lb-Ft (24 ± 3 N-m)
	Bearing Retainer Bolt (47)	45 ± 5 Lb- Ft (60 ± 7 N-m)
312	Inlet Bolt (4)	100 ± 5 Lb-Ft (135 ± 7 N-m)
	Thrust Plate Bolt (91)	60 ± 5 Lb-Ft (80 ± 7 N-m)
	Inboard Cover Bolt (4 or 93)	130 ± 10 Lb-In (176 ± 13 N-m)
	Idler Stop Bolt (81)	35 ± 2 Lb-Ft (47 ± 3 N-m)
	Bearing Retainer Bolt (47)	45 ± 5 Lb- Ft (60 ± 7 N-m)
350	Inlet Bolt (4)	180 ± 10Lb-Ft (245 ± 20 N-m)
	Thrust Plate Bolt (91)	60 ± 5 Lb-Ft (80 ± 7 N-m)
	Inboard Cover Bolt (4 or 93)	180 ± 10 Lb-Ft (245 ± 20 N-m)
	Idler Stop Bolt (81)	65 ± 5 Lb-Ft (88 ± 7 N-m)
	Bearing Retainer Bolt (47)	45 ± 5 Lb- Ft (60 ± 7 N-m)
400	Inlet Bolt (4)	150 ± 10 Lb-Ft (203 ± 13 N-m)
	Thrust Plate Bolt (91)	45 ± 5 Lb- Ft (60 ± 7 N-m)
	Inboard Cover Bolt (4 or 93)	220 ± 15 Lb-Ft (298 ± 20 N-m)
	Idler Stop Bolt (81)	35 ± 2 Lb-Ft (47± 3 N-m)
	Bearing Retainer Bolt (47)	35 ± 2 Lb-Ft (47± 3 N-m)

I. TROUBLESHOOTING

For assistance with troubleshooting see General Instruction Manual, SRM00046.

J. FIELD AND FACTORY SERVICE AND PARTS

Imo Pump maintains a staff of trained service personnel that can provide pump installation, pump start-up, maintenance/overhaul and troubleshooting supervision as well as installation and maintenance training.

Our factories provide maintenance as well as overhaul and test facilities in the event user prefers to return pumps for inspection or overhaul. Pumps that have been factory-overhauled are normally tested and warranted “as-new” for a period of one year from date of shipment. For either field service or factory overhaul assistance, contact your local Imo Sales Office or representative at Technical/Customer Service Department in Monroe, NC, USA.

Most pumps have repair kits available. Minor Repair Kits are used to repair leaking seals, bad bearings and/or for re-assembly after pump tear-down. They include (as applicable) pump shaft seals, packing, all gaskets/O-rings and bearings. Major Repair Kits are sufficient to rebuild completely worn-out pumps to “as-new” condition. They include all parts found in Minor Repair Kits plus all major internal parts subject to wear. Since kits have all necessary parts, it is preferred that they be purchased rather than selecting individual parts. When parts are individually selected from Parts List, some needed components are often overlooked. In addition, mixing worn or used parts with new parts risks rapid wear and shortened service life from new parts.

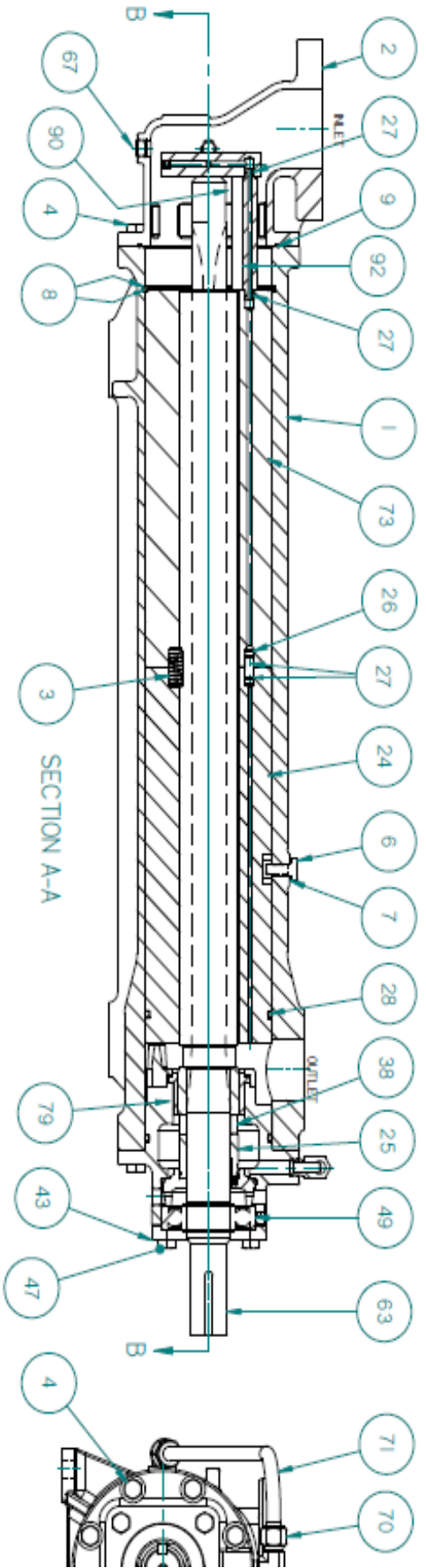
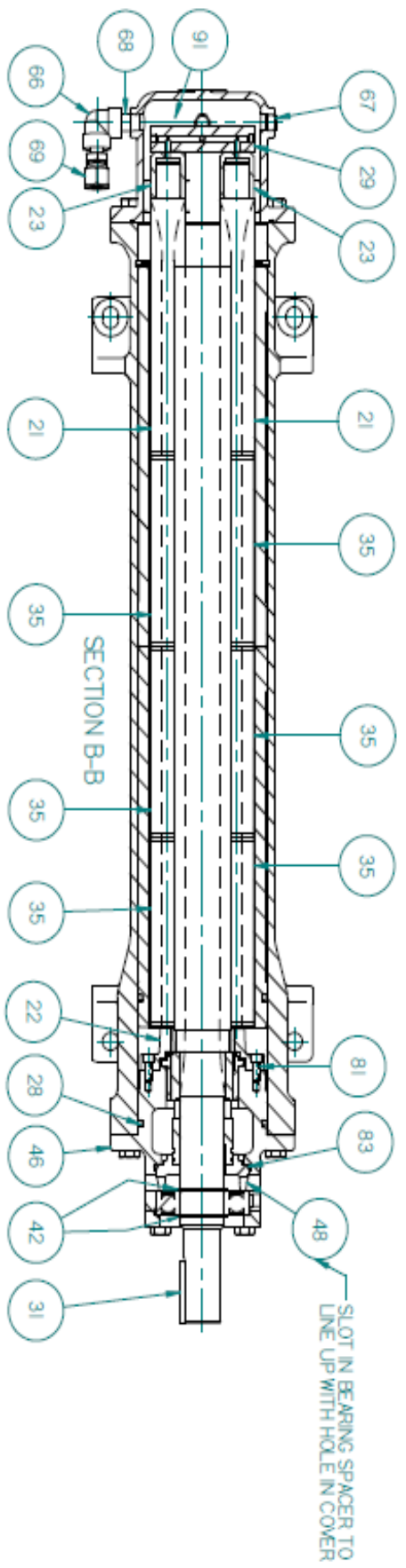

BK12DZH-312 Assembly

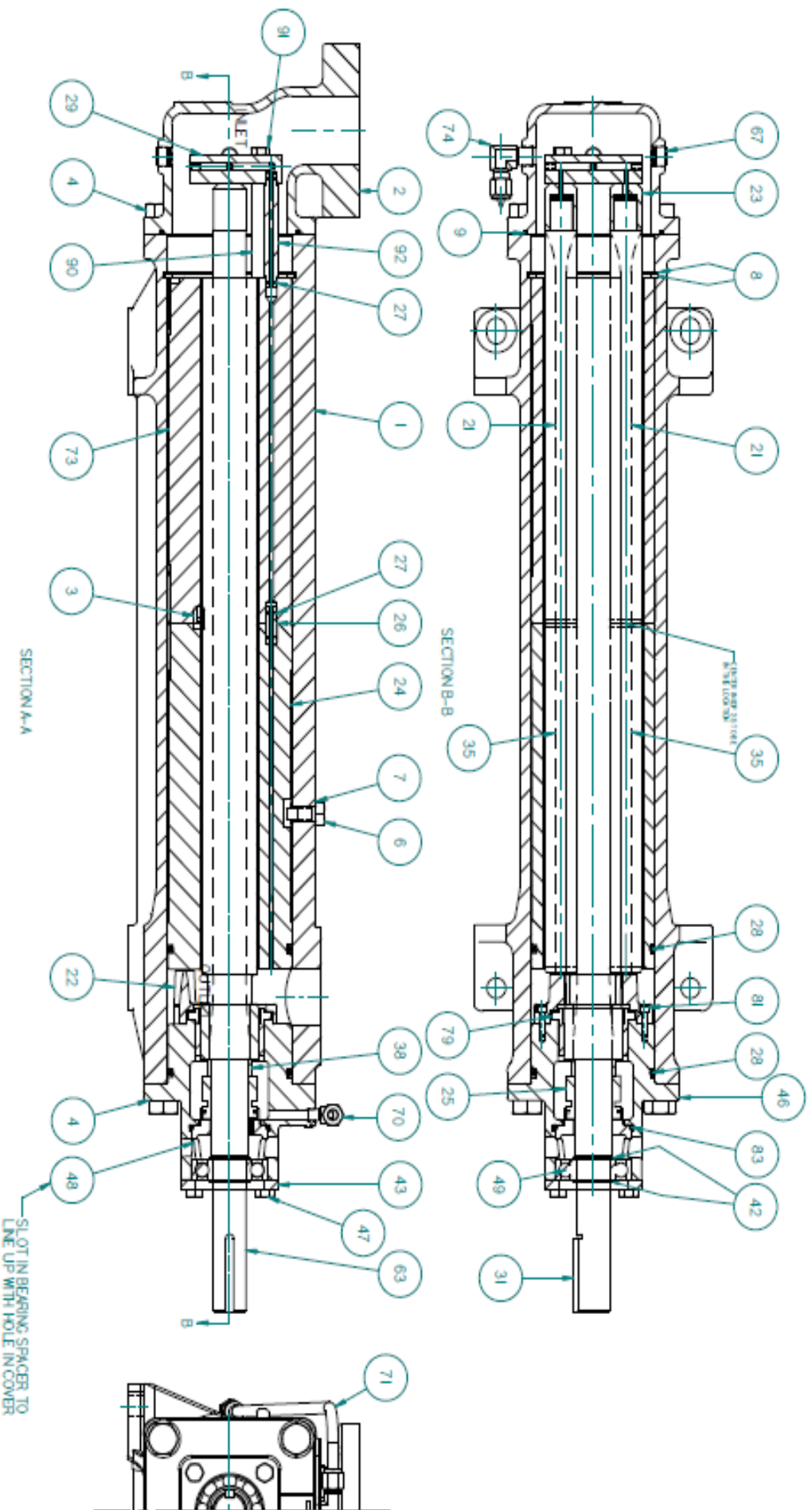

BK12DZH-187AND 250 ASSEMBLY

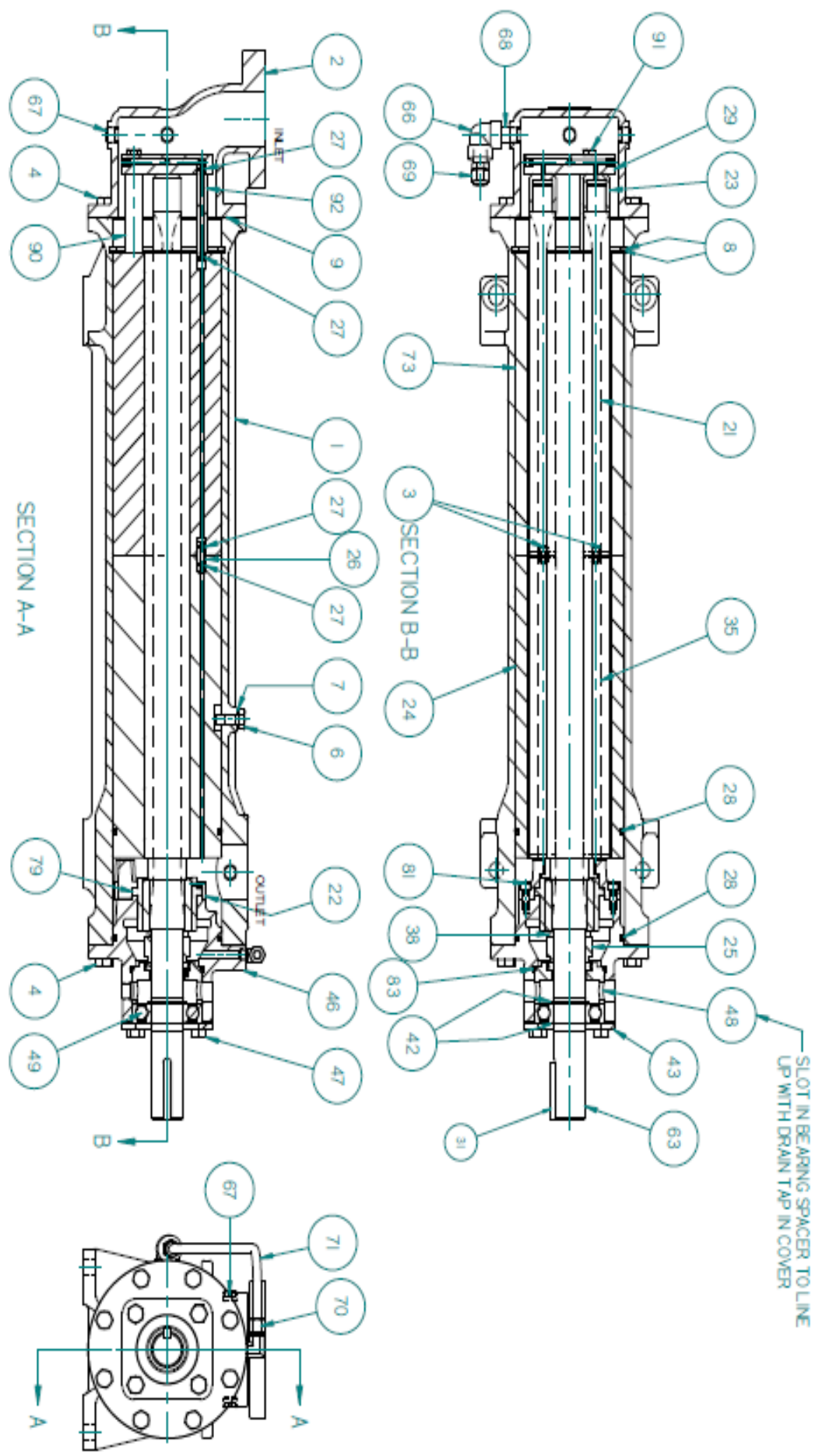

BK12DHz-275 AND 350 ASSEMBLY

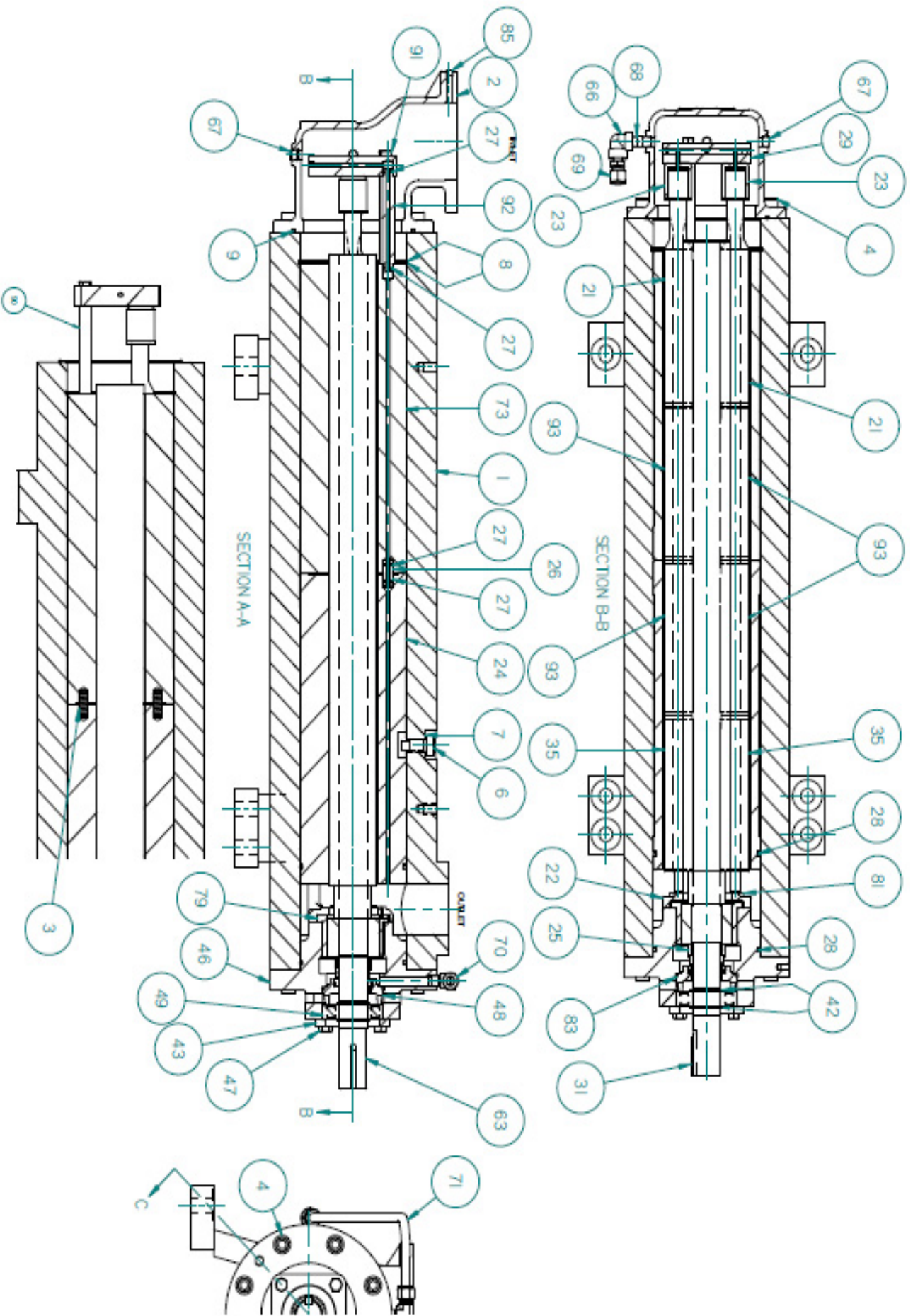

BK12DZH_ - 400_ Assembly

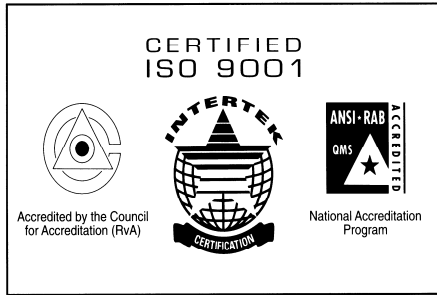

CIRCOR

1710 Airport Road
PO Box 5020
Monroe, NC USA
28111.5020

Tel: +1.877.853.7867

Email: cc@circor.com

Web: www.circorpt.com

