



**INSTRUCTIONS and PARTS LIST**

**SERIES N3D  
PUMP SIZES 137, 187**

**WARNING**

**READ CA-1 AND THIS INSTRUCTION BOOK BEFORE  
INSTALLATION, OPERATION, OR MAINTENANCE**

This manual now is  
identified as part no.  
SRM00065

**INSTRUCTIONS N3D-A (R-1)**

## FOREWORD

This instruction manual covers the Series N3D Series IMO Pump sizes 137 and 187. The specific models covered by this manual are identified in Table 1. Refer to the assembly drawing, Figures 4 through 9, corresponding to your pump type as you use this instruction manual. The type of each particular pump is identified on the pump nameplate. Refer to Figure 1 for definition of type designator.

The inserted CA-1 book deals with installation, operation, maintenance and troubleshooting that cover the entire range of pumps. The maintenance section of this manual covers disassembly and assembly procedure.

The Series N3D pumps and their appurtenances are designed, fabricated, inspected, tested and stamped in accordance with Section III, Class 3 of the ASME Boiler and Pressure Vessel Code. All internal wearing and sealing parts are standard commercial parts and can be replaced readily. All pressure retaining parts must be purchased in accordance with ASME Code requirements applicable.

**TABLE 1  
N3D SERIES IMO PUMP TYPES**

<b>Pump Type</b>	<b>Assembly Drawing No.</b>	<b>Figure No.</b>	<b>Pump Type</b>	<b>Assembly Drawing No.</b>	<b>Figure No.</b>
<b>N3DBS-137</b>	<b>SD-5546</b>	<b>4</b>	<b>NC3DBS-137</b>	<b>SF-5701</b>	<b>6</b>
<b>N3DHS-137</b>	<b>SD-5546</b>	<b>4</b>	<b>N3DBS-187</b>	<b>SD-5541</b>	<b>7</b>
<b>NA3DBS-137</b>	<b>SD-5555</b>	<b>5</b>	<b>NA3DBS-187</b>	<b>SD-5556</b>	<b>8</b>
<b>NB3DBS-137</b>	<b>SF-5701</b>	<b>6</b>	<b>NB3DBS-187</b>	<b>SF-5695</b>	<b>9</b>

## ORDERING INSTRUCTIONS

All correspondence pertaining to renewal parts for the equipment must refer to the instruction book number and should be addressed to the nearest IMO Pump Division Sales office or representative listed in the CA-1 book.

The handling of renewal orders will be greatly facilitated if the following directions are carefully observed.

1. Give the number of the instruction book.
2. Give the serial number of the machine for which part is desired. This number appears on the nameplate.
3. Designate the desired part by the number and names as listed in this instruction book.
4. Give the drawing number or figure number in which the part is shown.

## STRUCTURAL LIMITS

Operating conditions, such as speed, fluid viscosity, inlet pressure, discharge pressure, temperature, filtration, duty cycle, mounting, drive type, etc. are interrelated. Due to these variable conditions, the specific application may be different from that of the structural limitations. This equipment must not be operated without verification that operating requirements are within published capabilities as shown in the appropriate pump data book (available from local IMO Pump Division offices and representatives).

Under no circumstances are the following structural limitations to be exceeded.

**DISHCHARGE PRESSURE:** 150 PSIG (Maximum)

**MAXIMUM SPEED:** 4400 RPM

**VISCOSITY:** 32 SSU Minimum  
3000 SSU Maximum

**TEMPERATURE:** 0° to 160° F for Type B Shaft Seal  
0° to 250° F for Type H Shaft Seal

**SUCTION:** 75 PSIG nominal maximum suction pressure

**ROTATION:** Clockwise only facing pump shaft.

**DRIVE:** Direct

**FILTRATION:** 100 Mesh minimum recommended

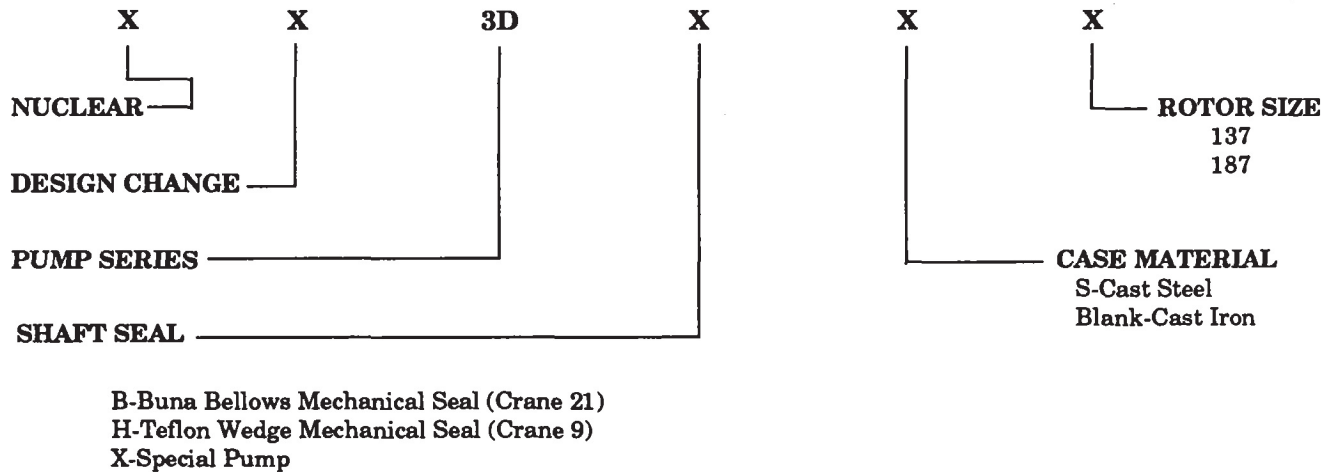

**FIGURE 1. Definition of Model Designator of N3D Series Pumps.**

## DESCRIPTION

The N3D IMO Pump has only three moving parts, one power rotor and two idlers, which operate inside the rotor housing.

Fluid entering the pump suction inlet flows to the end of the rotors. At the rotor ends it enters the rotor set and the smooth intermeshing of these rotors propels the fluid axially in a smooth continuous flow, without churning, pocketing or pulsating action, to the discharge chamber where the fluid leaves the pump.

N3D Pumps are equipped with mechanical seals. Fluid being pumped is supplied to the seals through the clearance between the balance piston on the power rotor and the inboard cover. Entering fluid lubricates and cools the mechanical seal and is then returned internally back to the pump suction.

Two types of seals are installed in N3D Pumps. Pump designator B identifies a Crane 21 type seal illustrated in Figure 2. Designator H identifies a Crane 9 type seal and is illustrated in Figure 3.

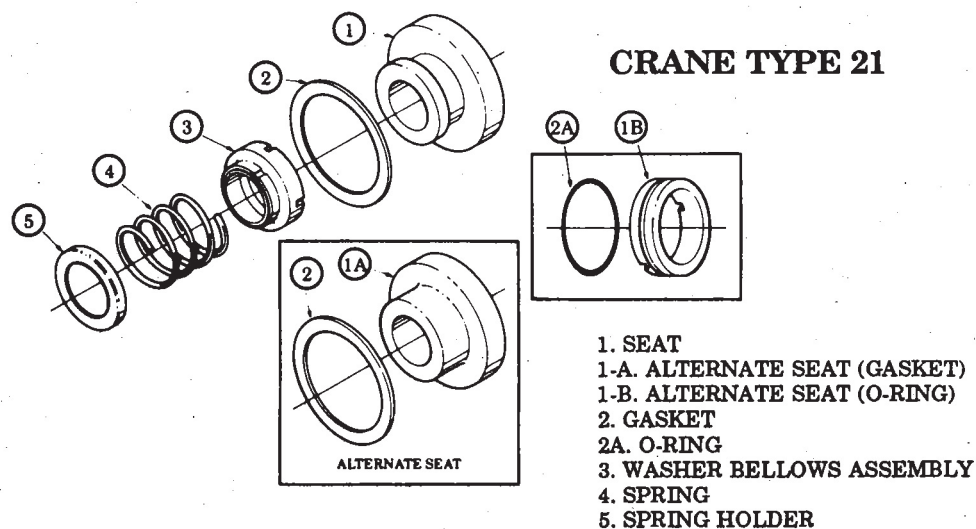

**FIGURE 2. Crane Type 21 Seal**

### CRANE TYPE 9

- 1. SEAT
- 1-A. ALTERNATE SEAT
- 2. GASKET
- 2-A. O-RING
- 3. SNAP RING
- 4. WASHER
- 5. CHEMLON RING
- 6. DISC
- 7. RETAINER
- 8. SET SCREW
- 9. SPRING
- 10. RETAINING CLIP

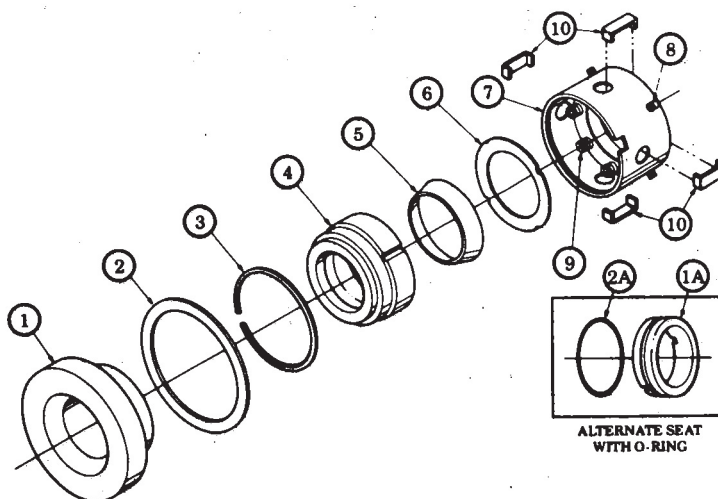

**FIGURE 3. Crane Type 9 Seal**



## MAINTENANCE

### PUMP DISASSEMBLY

#### NOTE

Refer to applicable pump drawing and parts list during disassembly and assembly. Obtain pump type from the nameplate then refer to Table 1 to identify applicable Assembly Drawing number and Figure number.

**GENERAL:** Close the inlet and outlet valves, lock and tag "Out of Service." De-energize pump driver motor controller and tag "Out of Service." Vent all pressure from pump case. Disconnect coupling and remove pump from driver and coupling hub from pump. Remove coupling key (016).

Remove bolts (010) and cover (026) with O-ring (008). Remove bolts (023) and lockwasher (024). Removal of bolt (023) will remove thrust plate (021) and spacer (022). Slide idlers (019) from pump housing (002).

#### NOTE

Rotate idlers (019) when removing from housing (002).

Remove bolt (018) and retainer (017). Pull power rotor (011) from cover (009). Removal of power rotor will include removal of truarc rings (013), ball bearing (015), spacer (014) and the mechanical seal (025).

Remove truarc ring (013) nearest key slot in power rotor (011). Using a bearing puller or bench press, remove ball bearing (015). Remove remaining truarc ring (013), spacer (014) and mechanical seal (025) from power rotor (011).

Remove inboard cover by removing bolts (010). Remove O-ring (007). Figure 7, 8 and 9. Remove spacer (027).

FIGURES 4, 6, 7 and 9. Remove O-ring (005) from tube pin located in inboard cover (009).

#### NOTE

Tube is installed in inboard cover (009) using Loctite harding compound and should not be removed as it is not serviced separately from inboard cover (009).

FIGURES 5 and 8. Tube (004) either remained in housing (002) or was removed with inboard cover (009). Remove tube (004) and O-rings (005) from tube (004).

Remove mechanical seal (025) seat gasket from inboard cover (009) mechanical seal bore. Remove spirolox ring (052) from pump case (001).

Slide housing (002) from case. Housing (002) is removed by pushing from inboard end of pump and pulling housing out the inlet end of case. Remove O-ring (006) from housing (002).

**FIGURE 6.** If removal of check valve (065) is required, disassemble unit by removing truarc ring (068) and slide O-ring (066) fitted spacer (067) from case (001). Remove check valve (065) with O-ring (064).

**NOTE**

Check valve (065) is replaced as a unit and is not serviced separately.

**FIGURE 9.** If removal of check valve (060) is required, disassemble unit by removing truarc ring (063) and slide O-ring (061) fitted spacer (062) from case (001). Remove O-ring (059) fitted chech valve (060).

**NOTE**

Check valve (060) is replaced as a unit and is not serviced separately.

**PUMP ASSEMBLY**

**NOTE**

Assembly steps are outlined in paragraph form in the correct assembly procedure. All steps are to be followed in the outlined sequence unless a specific pump Figure is identified. When a specific Figure number is identified, the procedure is applicable only to the pumps identified by the Figure number. Refer to Table 1 for the Series N3D pump assembly and Figure number for your specific pump model.

**GENERAL:** Inspect, clean and wipe all bolts and internal or rotating parts with light lubricating oil immediately before assembly. Do Not open seal on bearing packages until they are to be installed. A new mechanical seal should be installed if the old seal has been disturbed. A new bearing should be installed when a seal is replaced or if unit has been in operation for an extended length of time. Replace all O-rings rotate the power rotor (007) frequently during installation to assure freedom of rotation.

Coat housing (002) rotor bores and outer surface with oil. Install O-ring (006) in housing (002) O-ring groove. Slide housing in case (001) with O-ring end of housing entering inlet end of case. Install spirolox ring (052) in case (001) groove.

**NOTE**

Housing (002) will be aligned to receive tube in inboard cover in later step.  
Housing should be installed with rotor bores in a horizontal plan.

**FIGURES 4, 6, 7 and 9.** Coat inboard cover (009) with oil. Slide O-ring (005) on tube.

**FIGURES 5 and 8.** Coat inboard cover (009) and tube (004) with oil. Slide O-rings (005) on tube (004) and insert tube (004) in inboard cover (009).

**FIGURES 7, 8 and 9.** Slide spacer (027) over tube and O-ring (005) located on inboard cover.

With inboard cover (009) coated with oil, slide O-ring (007) on inboard cover. Slide inboard cover (009) in case (001).

**NOTE**

Tube with O-ring (005) must be aligned with housing (002) tube bore. Using pump outlet port, observe tube alignment when inserting inboard cover (009).

Rotate inboard cover (009) as required to align bolt (010) holes. Install bolts (010) and torque Figures 4, 5 and 6 pumps to 45 ft. lbs. ( $\pm 2$  ft. lbs.). Torque bolts (010) on Figures 7, 8 and 9 pumps to 35 ft. lbs. ( $\pm 2$  ft. lbs.).

Coat power rotor (011) with oil. Slide mechanical seal (025) over power rotor (011) shaft until the seal rests on power rotor (011) balance piston. Do not install gasket furnished with seal. Crane Type 21 Seal: Slide spring holder end of mechanical seal (025) on power rotor first followed by spring and washer assembly. Crane Type 9 Seal: Slide spring holder end with set screws on power rotor first. With mechanical seal resting on power rotor balance piston, lock set screws and remove clips.

Slide spacer (014) on power rotor (011) shaft. Install truarc ring (013) in power rotor (011) groove nearest mechanical seal. Using a sleeve and pressing only on inner race of ball bearing (015), press ball bearing (015) on power rotor (011). Install truarc ring (013) in power rotor (011) groove nearest key (016) slot.

Install gasket, furnished with mechanical seal, in inboard cover (009) mechanical seal bore. Coat assembled power rotor (011) with oil. Slide power rotor (011) in inboard cover and housing (002) centering each part as it enters the inboard cover (009). Use bearing retainer (017) to press power rotor (011) assembly in inboard cover (009) by installing bolts (018) and tighten. Torque bolts (018) on Figures 4, 5 and 6 pumps to 20 ft. lbs. ( $\pm 2$  ft. lbs.). Torque bolts (018) on Figures 7, 8 and 9 pumps to 18 ft. lbs. ( $\pm 2$  ft. lbs.).

Coat idlers (019) with oil and slide idlers (019) in housing (002) turning the idler (019) as it enters. Slide washers (024), thrust plate (021) and spacers (022) on bolts (023). Position bolt (023) assembly on housing (002) and tighten bolts (023). Torque bolts (023) to 10 ft. lbs. ( $\pm 2$  ft. lbs.).

Install O-ring (008) in cover (026) O-ring groove. Install cover (026) on case (001) using bolts (010). Torque cover bolts (010) on Figures, 4, 5 and 6 pumps to 45 ft. lbs. ( $\pm 2$  ft. lbs.). Torque cover bolts (010) on Figures 7, 8 and 9 pumps to 35 ft. lbs. ( $\pm 2$  ft. lbs.).

**FIGURE 6.** Coat check valve (065) with oil and slide O-ring (064) in check valve (065) O-ring groove. Coat spacer (067) with oil and slide O-ring (066) in spacer (067) O-ring groove. Slide check valve (065) and spacer (067) in case (001). Install truarc ring (068) in case (001) ring groove.

**FIGURE 9.** Coat check valve (060) with oil and slide O-ring (061) in check valve (060) O-ring groove. Coat spacer (062) with oil and slide O-ring (061) in spacer (062) O-ring groove. Slide check valve (060) and spacer (062) in case (001). Install truarc ring (063) in case (001) ring groove.

Install coupling key (016) and coupling hub.

PARTS LIST

ITEM	PART DESCRIPTION	ITEM	PART DESCRIPTION
001	Case	023	Bolt 5/16 x 4 (2)
002	(2) Housing	024	Lockwasher 5/16 (2)
003	Plug 1/8 SHP	025	(1) Seal
004	(3) Tube	026	Cover
005	(1) O-ring	027	(4) Spacer
006	(1) O-ring	028	Nameplate
007	(1) O-ring	029	Screw, Drive U #6 x 1/4 (8)
008	(1) O-ring	034	(7) Inboard Cover
009	Inboard Cover	052	(2) Spirolox Ring
010	Bolt 1/2 x 1-1/4	053	Nameplate
011	(2) Power Rotor	058	(5) Nameplate
013	(1) Truarc Ring (2)	060	(8) Check Valve
014	Spacer	061	(8) O-ring
015	(1) Ball Bearing	062	(8) Spacer
016	Key	063	(8) Truarc Ring
017	Retainer	064	(6) O-ring
018	Bolt 3/8 x 1 (4)	065	(6) Check Valve
019	(2) Idler (2)	066	(6) O-ring
021	(2) Thrust Plate	067	(6) Spacer
022	Spacer (2)	068	(6) Truarc Ring

NOTES:

- (1) Items required for Minor Repair Kit
- (2) Items required for Major Repair Kit
- (3) Figures 5 and 8 pumps only
- (4) Figures 7, 8 and 9 pumps only
- (5) Figures 4, 5 and 6 only
- (6) Figure 6 only
- (7) Figure 8 only
- (8) Figure 9 only

All quantities are one except when noted in parentheses after part description.

SPECIAL NOTE:

IMO Pump Division recommends that repair parts be ordered by Minor or Major Repair Kit. When ordering kit, identify Minor or Major repair, pump model and serial number.



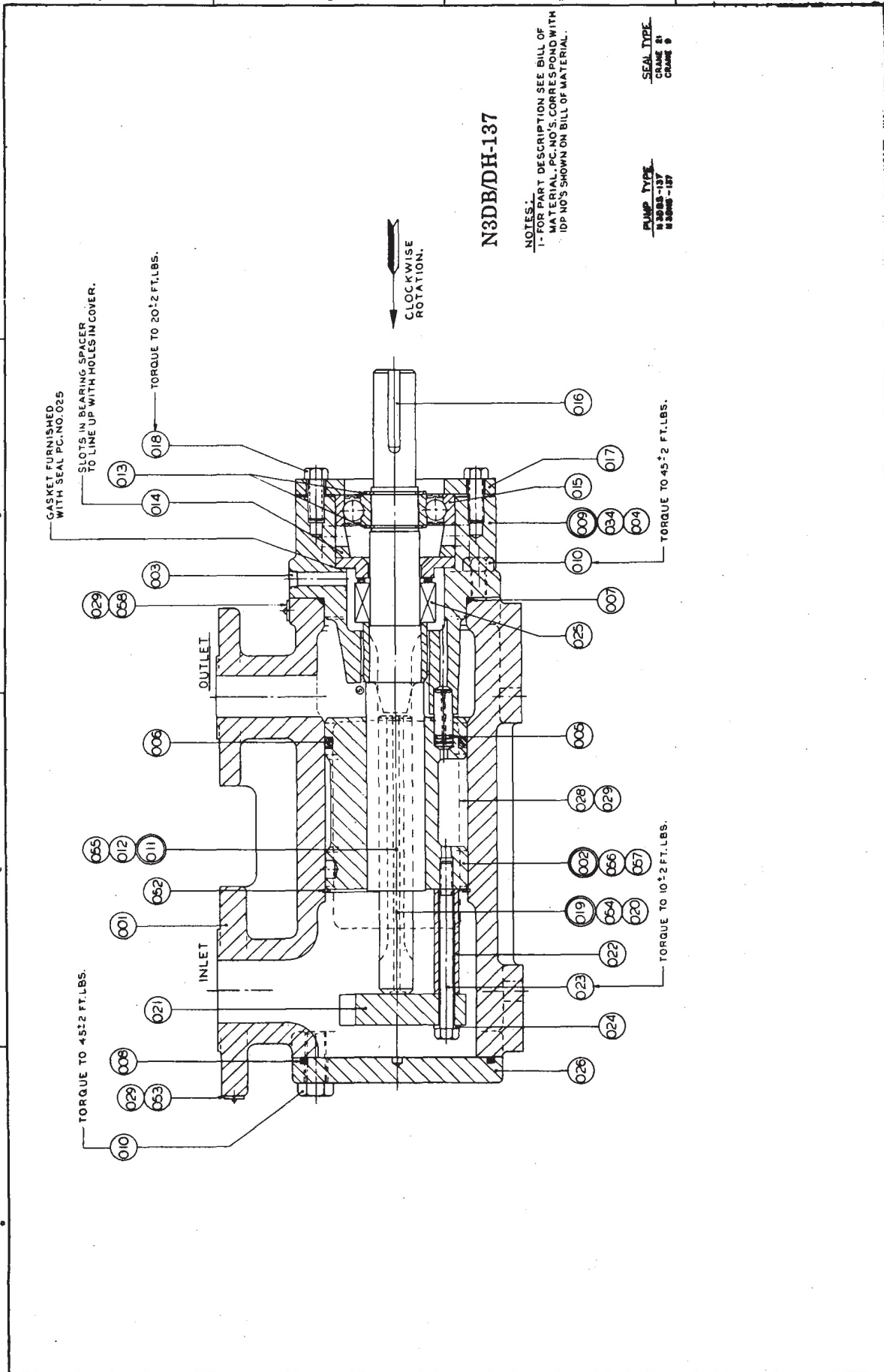

**FIGURE 4. Pump Assembly Drawing**  
 SD5546

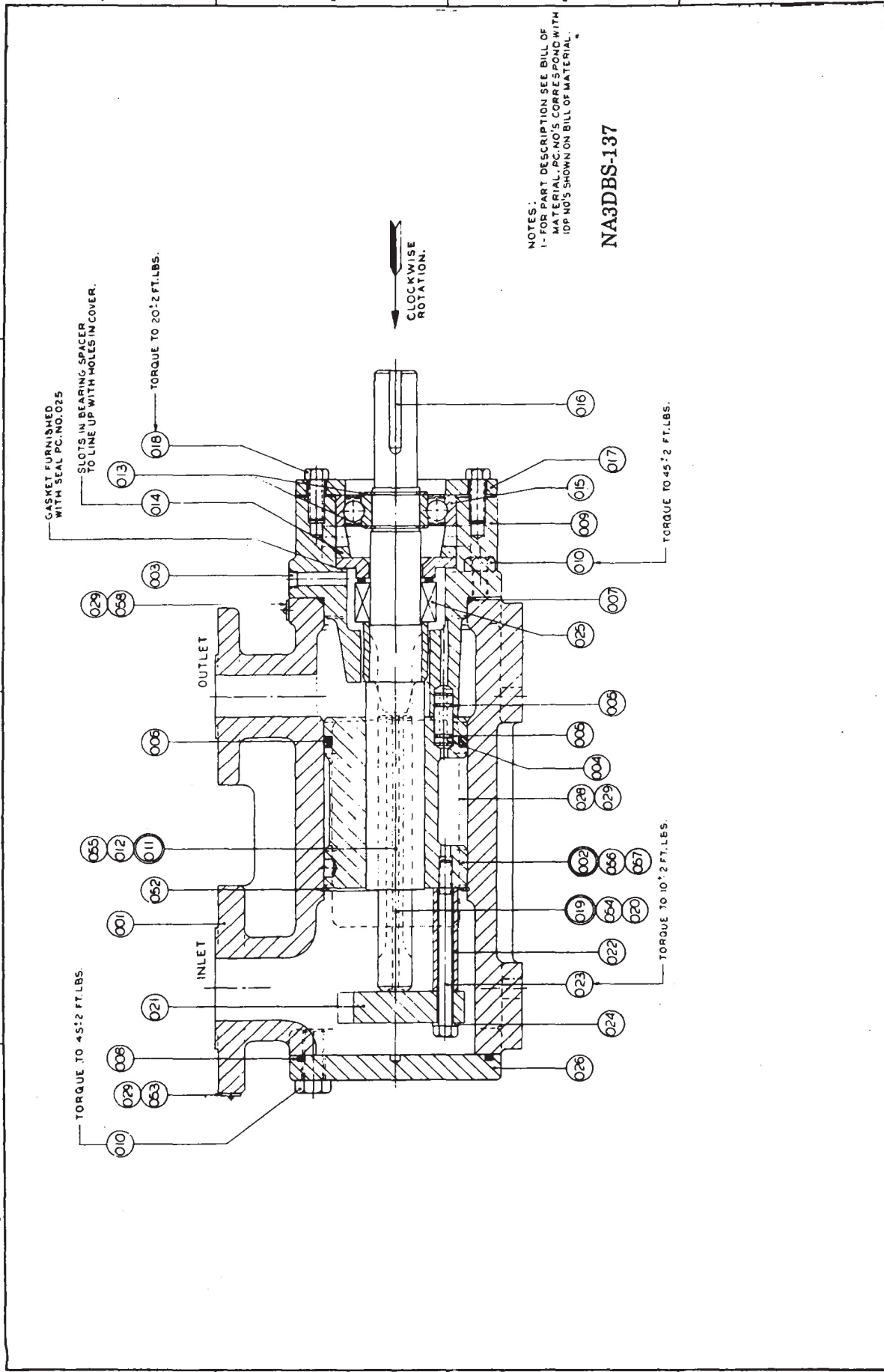
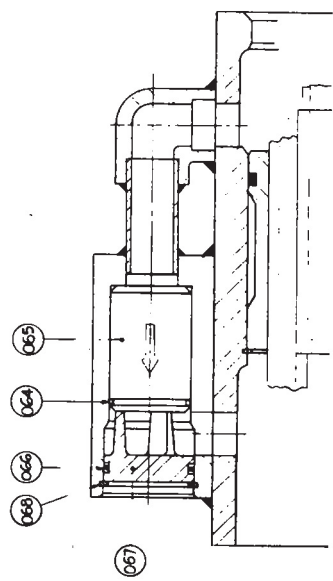
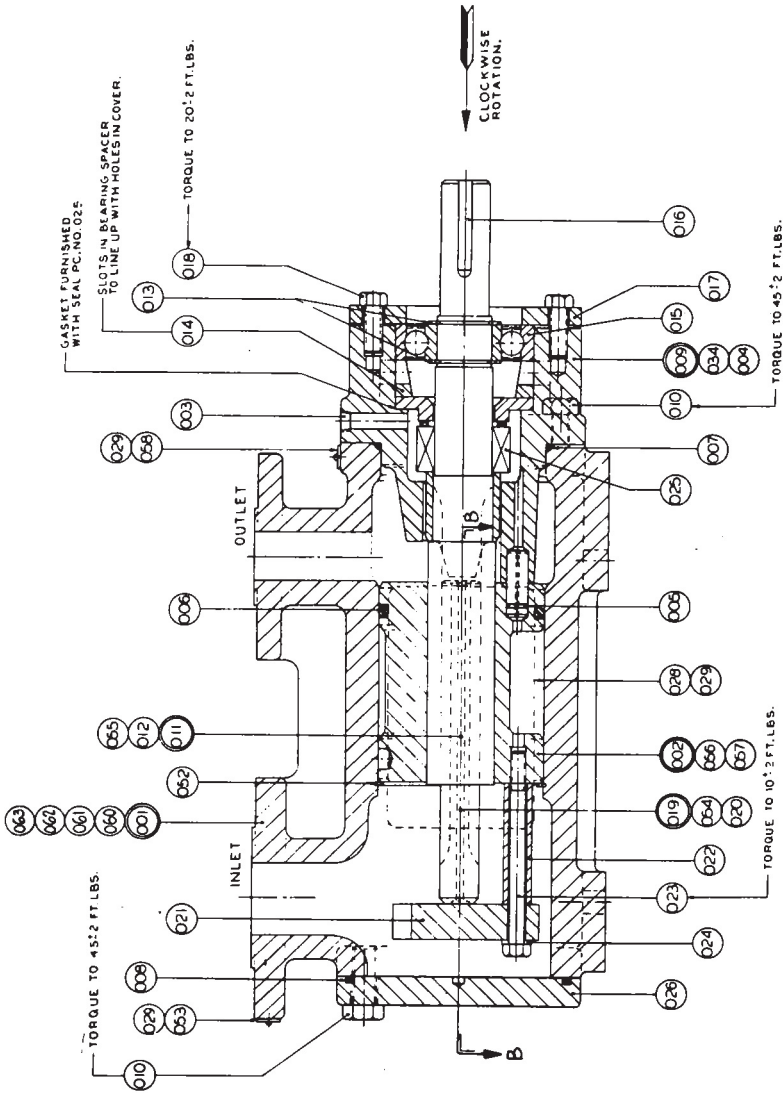

FIGURE 5. Pump Assembly Drawing  
 SD-5555





SECTION B-B



NOTES:  
 1- FOR PART DESCRIPTION SEE BILL OF MATERIALS  
 2- ALL DIMENSIONS ARE TO BE SHOWN WITH DIMENSIONS SHOWN ON BILL OF MATERIAL.

THIS DRAWING MAY BE USED FOR THE CONSTRUCTION OF THE FOLLOWING PUMP TYPES:  
 N 3 D B S - 137 (50 PSI R/SETTING)  
 N C 3 D B S - 137 (30 PSI R/SETTING)

FIGURE 6. Pump Assembly Drawing  
 SF-5701

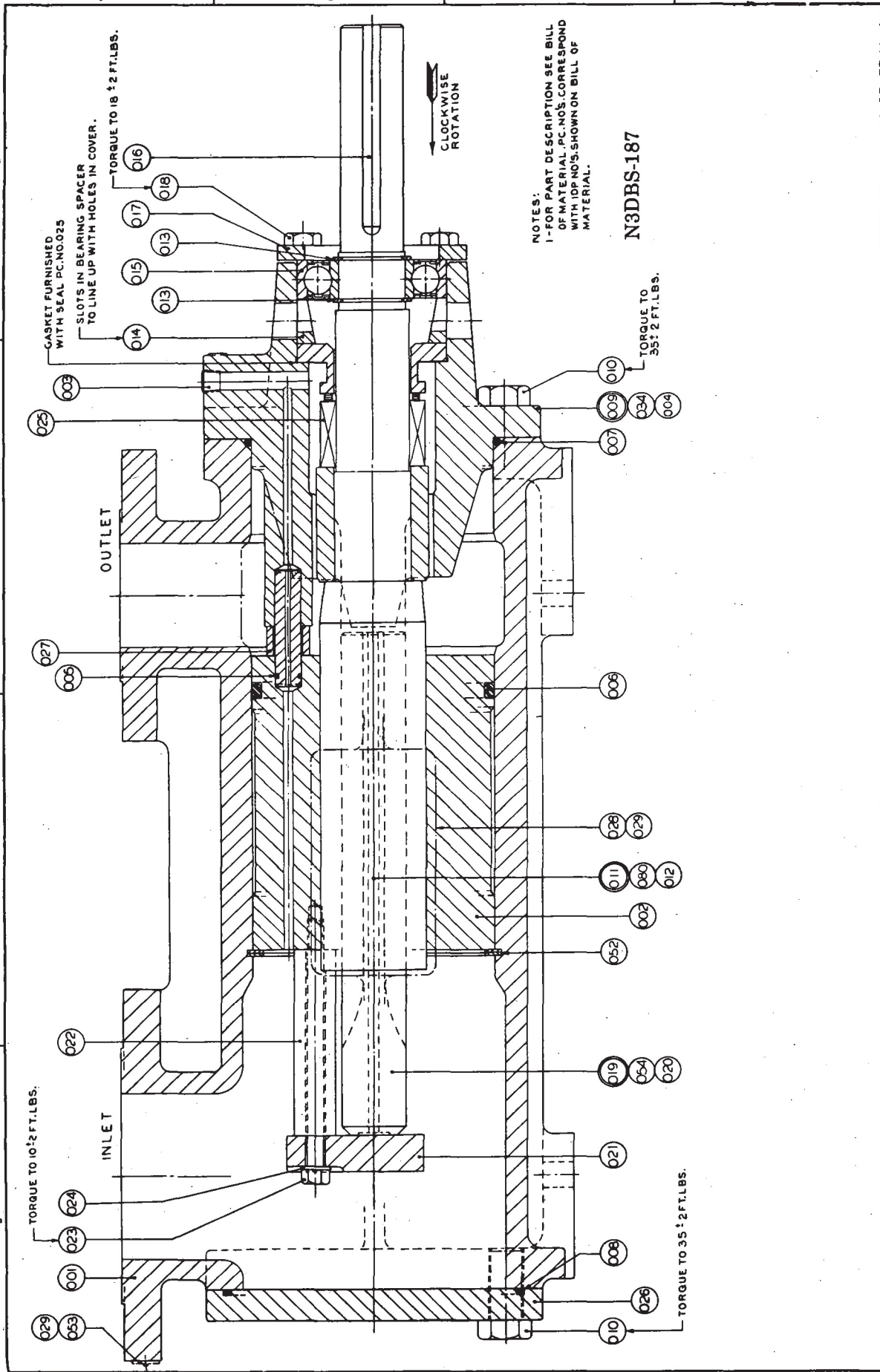
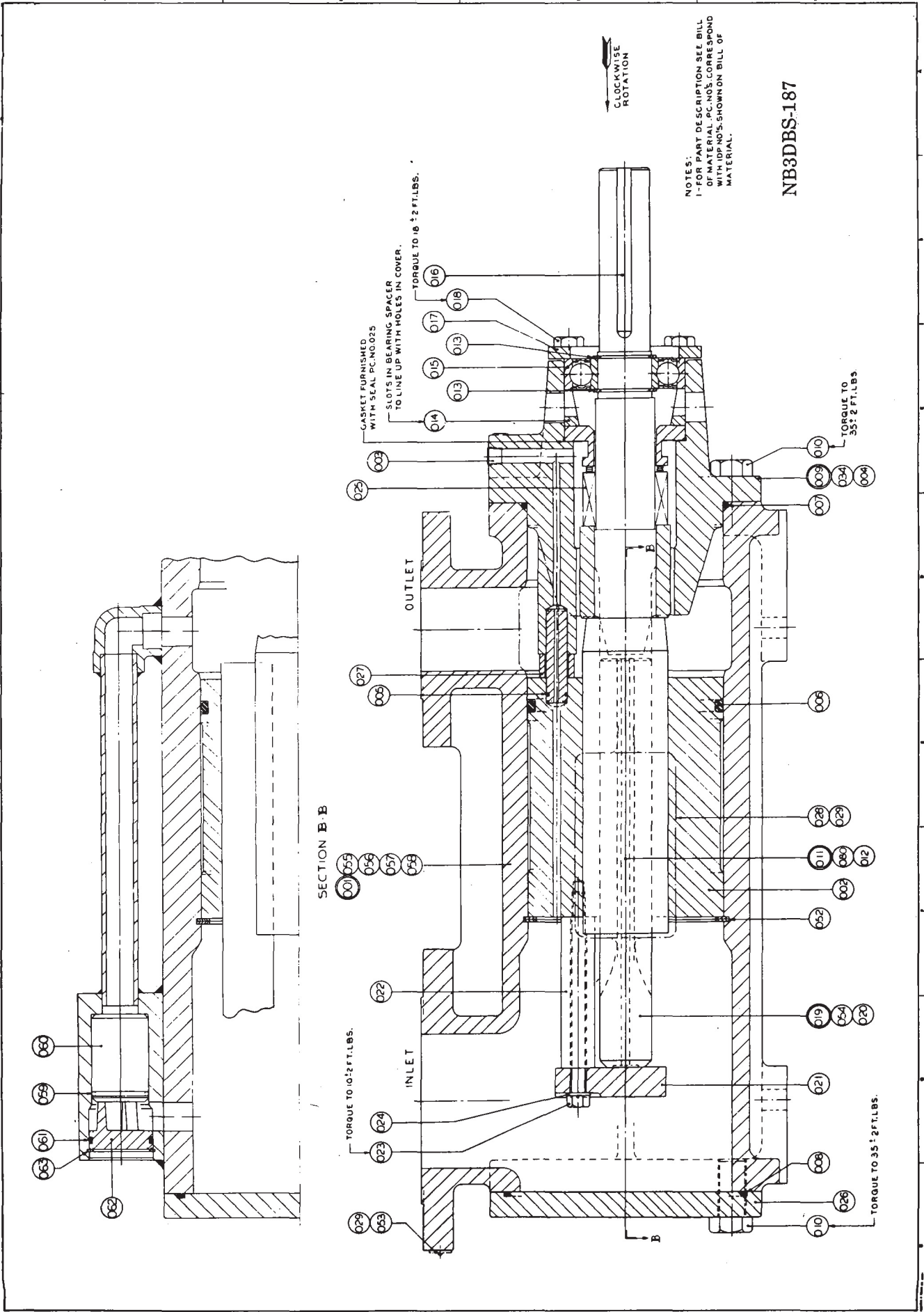

FIGURE 7. Pump Assembly Drawing

SD-5541





**FIGURE 9. Pump Assembly Drawing**

SF-56

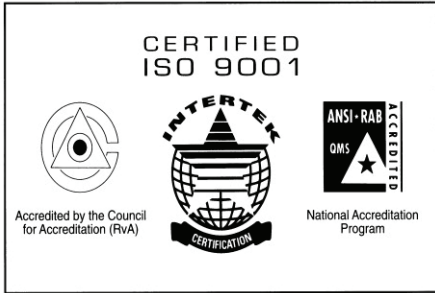

**CIRCOR**

1710 Airport Road  
PO Box 5020  
Monroe, NC USA  
28111.5020

Tel: +1. 877.853.7867

Email: [cc@circor.com](mailto:cc@circor.com)

Web: [www.circorpt.com](http://www.circorpt.com)

