



**INSTRUCTION MANUAL**

**AND**

**PARTS LIST**

**FOR**

**\_G3D-187, 218, 250 and 312 SERIES PUMPS**  
**(Idler Cup and Hydrostatic Thrust Designs)**

	<b>WARNING</b>	
<p>The Imo General Installation Operation, Maintenance, and Troubleshooting Manual, (No. SRM00046), along with this manual as well as all other component manuals supplied with these type units should be read thoroughly prior to pump installation, start-up, operation, maintenance or troubleshooting.</p>		

<b>Manual No. SRM00061</b>	<b>REV 09 (20-0051)</b>	<b>February, 2020</b>
----------------------------	-------------------------	-----------------------

## IMPORTANT NOTE

The importance of seal chamber priming cannot be overemphasized. Due to the prevalence of seal damage and leakage caused by not filling the seal chamber with liquid before putting a pump in service, this page is located at the beginning of this document.

### SEAL CHAMBER PRIMING

Fill mechanical seal chamber with liquid to insure seal does not start dry. This can be done by removing seal vent set-screw and pouring liquid into vent passageway before opening pump inlet. Alternately, seal chamber can be vented in situations where inlet pressure is above atmospheric by opening inlet and discharge valves and then loosening seal vent plug to allow positive inlet pressure to push air out of seal chamber until oil flows from it. **See figure below.**

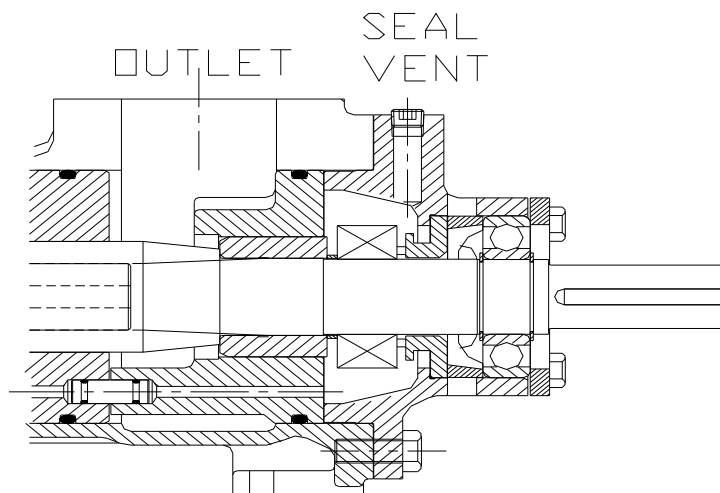

**Filling or Venting Seal Cavity Using Seal Vent**

#### CAUTION

Failure to fill or vent seal chamber as described above may cause damage to seal running faces which may result in seal leakage.



## READ THIS ENTIRE PAGE BEFORE PROCEEDING

FOR SAFETY OF PERSONNEL AND TO PREVENT DAMAGE TO EQUIPMENT, THE FOLLOWING NOMENCLATURE HAS BEEN USED IN THIS MANUAL:

	<b>DANGER</b>	
Failure to observe precautions noted in this box can result in severe bodily injury or loss of life.		

	<b>WARNING</b>	
Failure to observe precautions noted in this box can cause injury to personnel by accidental contact with equipment or liquids. Protection should be provided by user to prevent accidental contact.		

<b>CAUTION</b>		<b>ATTENTION</b>
Failure to observe precautions noted in this box can cause damage or failure of equipment.		

Non compliance of safety instructions identified by the following symbol could affect safety for persons:  <div style="text-align: center;"></div>	Safety instructions where electrical safety is involved are identified by:  <div style="text-align: center;"></div>	Safety instructions which shall be considered for reasons of safe operation of pump and/or protection of pump itself are marked by the sign:  <div style="text-align: center;"><b>ATTENTION</b></div>
---	--	---

<b>ATTENTION</b>
If operation of pump is critical to your business, we strongly recommend you keep a spare pump or major repair kit in stock at all times. As a minimum, a minor repair kit (o-rings, gaskets, shaft seal and bearings) should be kept in stock so pump refurbishment after internal inspection can be accomplished.

### Table of Contents

Seal Chamber Priming.....	2
Safety and Table of Contents.....	3
A. General Instructions, introduction, Description of Equipment.....	4
B. Assembly Drawing List and Mechanical Seal Types.....	5
C. Pump Model Identification, Ordering Instructions.....	6
D. Operating Limits .....	7
E. Parts Lists.....	8-9
G. Pump Disassembly and Reassembly (Pumps with seals).....	10
H. Mechanical Seal Information .....	17-23
I. Pump Disassembly and Reassembly (Packing Pumps).....	24-26
J. Troubleshooting, Field and Factory Service and Parts.....	26
K. Assembly Drawings .....	27-35
L. Imo Address and Phone Numbers .....	36

## A. GENERAL INSTRUCTIONS

The instructions found herein cover the disassembly, assembly and parts identification of \_G3D-187, 218, 250 and 312 series pumps. Both the original design with idler cups and the newer design with hydrostatic idlers are covered.

**NOTE:** Individual contracts may have specific provisions that™ ry from this manual. Should any questions arise which may not be answered by these instructions, refer to **General Installation Operation, Maintenance, and Troubleshooting Manual, (No. SRM00046)**, provided with your order. For further detailed information and technical assistance please refer to **Imo Pump, Technical/Customer Service Department, at (704) 289-6511.**

This manual cannot possibly cover every situation connected with the installation, operation, inspection, and maintenance of equipment supplied. Every effort was made to prepare text of manual so that engineering and design data is transformed into the most easily understood wording. Imo Pump must assume personnel assigned to operate and maintain supplied equipment and apply this instruction manual have sufficient technical knowledge and are experienced to apply sound safety and operational practices which may not be otherwise covered by this manual.

In applications where equipment furnished by Imo Pump is to become part of processing machinery, these instructions should be thoroughly reviewed to ensure proper fit of said equipment into overall plant operational procedures.



### WARNING

If installation, operation, and maintenance instructions are not correctly and strictly followed and observed, injury to personnel or serious damage to pump could result. Imo Pump cannot accept responsibility for unsatisfactory performance or damage resulting from failure to comply with instructions.

## B. INTRODUCTION

This instruction manual covers series \_G3D-187, 218, 250 and 312 Imo pumps. This series of pumps has been designed for use in hydraulic, lubricating, seal, distillate, residual, fuel and crude oil applications. The model and design construction of each pump can be identified by the designator code on the pump nameplate. Definitions of model designators are identified in figure 1.

## C. DESCRIPTION OF EQUIPMENT

\_G3D-187, 218, 250 and Series pumps are positive displacement, rotary screw pumps consisting of a precision bored housing which encloses a driven screw (power rotor) and two intermeshing following screws (idler rotors). These screws when rotating form a succession of closures or cavities. As they rotate, fluid is moved axially from inlet port to outlet port in a continuous, uniform flow with minimum fluid pulsation and pump noise.

**Table 1**  
**SERIES G3D TYPICAL PUMP ASSEMBLY DRAWINGS**

	MECHANICAL SEAL					PACKING PUMPS	
<b>ROTOR SIZE</b>	187	218 and 250	Vertical 218	312		187	218 and 250
<b>FIGURE NO.</b>	18	19	20	21		23	24

**Table 2**  
**SERIES G3D PUMP SEAL TYPES**

ROTOR SIZES 187, 218, 250 and 312									
PUMP MODEL*	SEAL FIG. NO.	PUMP MODEL*	SEAL FIG. NO.	PUMP MODEL*	SEAL FIG. NO.	PUMP MODEL*	SEAL FIG. NO.	PUMP MODEL*	SEAL FIG. NO.
G3DB	6 or 7	G3DJS	8	G3DYST	E	BG3DHST	4 or 5	GG3DX	10
G3DBC	6 or 7	G3DJST	8	AG3DB	6 or 7	BG3DHT	4 or 5	GG3DXBJ	10
G3DBCST	6 or 7	G3DKCX	No Seal	AG3DBC	6 or 7	CG3DB	6 or 7	GG3DY	10
G3DBCSTX	6 or 7	G3DKHS	No Seal	AG3DBCS	6 or 7	DG3DB	6 or 7	GG3DYFC	10
G3DBH	6 or 7	G3DLCS	2 or 3	AG3DBCX	6 or 7	DG3DH	4 or 5	GG3DYJ	10
G3DBR	6 or 7	G3DNST	10	AG3DBS	6 or 7	EG3DBS	6 or 7	GG3DYJV	10
G3DBRS	6 or 7	G3DQCS	Flexibox	AG3DBST	6 or 7	EG3DBSP	6 or 7	GG3DYS	10
G3DBRST	6 or 7	G3DRS	(Special)	AG3DBTCS	6 or 7	EG3DNST	4 or 5	GG3DYSJ	10
G3DBS	6 or 7	G3DSCS	Sealol	AG3DBX	6 or 7	FG3DHXS	4 or 5	GG3DYSX	10
G3DBST	6 or 7	G3DSRJ	4 or 5	A3DESX	4 or 5	GG3DBS	6 or 7	GG3DYT	10
G3DBSU	6 or 7	G3DSS	10	AG3DH	4 or 5	GG3DBSX	6 or 7	GG3DYX	10
G3DC	4 or 5	G3DU	10	AG3DHC	4 or 5	GG3DHS	4 or 5	HG3DB	6 or 7
G3DCC	4 or 5	G3DV	6 or 7	AG3DHS	4 or 5	GG3DNJ	10	HG3DBS	6 or 7
G3DCCS	4 or 5	G3DVCS	6 or 7	AG3DHST	4 or 5	GG3DNT	10	KG3DH	4 or 5
G3DEST	4 or 5	G3DVCST	6 or 7	AG3DJST	8	GG3DNSJ	10	LAG3DHS	4 or 5
G3DET	4 or 5	G3DW	Packing	AG3DKHP	No Seal	GG3DNST	10	LAG3DKH	No Seal
G3DF	Packing	G3DXS	4 or 5	AG3DKHS	No Seal	GG3DNSTX	10	LAG3DNRST	10
G3DG	9	G3DY	10	AG3DKHX	No Seal	GG3DRS	13	LBG3DBRST	6 or 7
G3DH	4 or 5	G3DYCSB	10	AG3DNST	4 or 5	GG3DSJX	10	LBG3DBST	6 or 7
G3DHCS	4 or 5	G3DYCSBT	10	AG3DRS	13	GG3DUCST	10		
G3DHH	4 or 5	G3DYCST	10	AG3DXSJ	10	GG3DUSJ	10		
G3DHST	4 or 5	G3DYRST	10	AG3DV	6 or 7	GG3DUST	10		
G3DHX	4 or 5	G3DYSC	10	BG3DBST	6 or 7	GG3DUSTX	10		

\* Pump model precedes rotor size.

## D. PUMP MODEL IDENTIFICATION

This instruction manual covers Imo Series G3D-275 pumps. The model of each pump is identified on pump nameplate. Refer to figure 1 and table 1 for instructional keys when using this manual.

**Figure 1. Definitions of Model Designators**

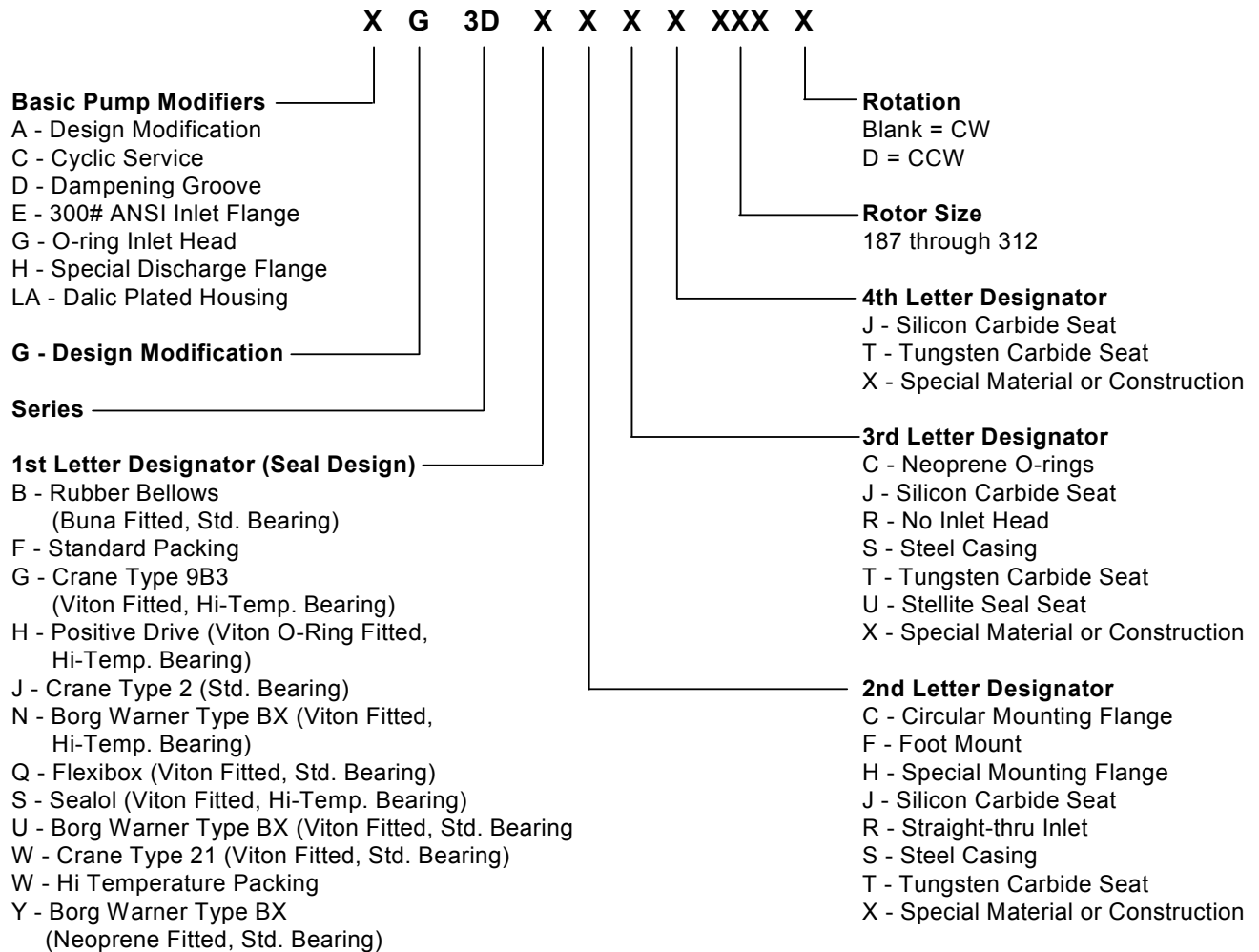

- 1 If you cannot positively identify your pump assembly in this book, contact Imo Pump's service department for assistance. Have pump model and serial number to assist in identification.
- 2 See Figure 26 for variations of pump inlets that might apply to your pump type.
- 3 See Figure 25 for variations of pump inboard cover/seal arrangements that might apply to your pump type.
- 4 See Seal Figures 2 through 10 for seal assembly variations as applicable to your pump type.

## E. ORDERING INSTRUCTIONS

When corresponding with Imo Pump regarding Series G3D-275 series pumps, refer to pump nameplate, this instruction manual, and assembly drawing as instructed below:

1. From pump nameplate, record pump model number, serial number, and manufactured date.
2. Record instruction manual number, revision, and date.
3. From instruction manual, record figure numbers that apply to replacement part(s).
4. From assembly drawing or parts list (see table 2) provide IDP number(s) and names for replacement part(s).
5. Give above information to your Imo service representative.

Imo sales and service representatives are listed herein and in General Instruction Manual, CA-1.

## F. OPERATION

### F.1 LIQUID LIMITATIONS

Never operate with thin liquids such as solvents or water. Pump is designed for liquids having general characteristics of oil.

### F.2 OPERATING LIMITS

	<b>CAUTION</b>	<b>ATTENTION</b>
Operating conditions, such as speed, fluid viscosity, temperature, inlet pressure, discharge pressure, filtration, duty cycle, drive type, mounting, etc., are interrelated. Due to these variable conditions, specific application limits may be different from operational limitations. Equipment must not be operated without verifying system operating requirements are within pump's capabilities.		

Under no circumstances are the following structural limitations to be exceeded.

MAXIMUM SPEED:	RPM					
	DISTILLATE OILS		LUBE AND SEAL OILS		RESIDUAL CRUDE OILS	
	TYPE B & H	TYPE B & H	TYPE F	TYPE B & H	TYPE F	
187	4400	4400	3000	1800 All Sizes	1800 All Sizes	
218	3600	3600	2500			
250	3600	3600	2150			
312	2500	2500				

Consult factory for allowable speeds for alternate seal arrangements.

VISCOSITY: ..... 33 SSU Minimum - Mechanical Seal Pumps  
 100 SSU Minimum - Packing Pumps  
 3000 SSU Maximum - Type B Mechanical Seal Pumps  
 Consult factory for allowable operating viscosity for other seal types at specific speeds and pressures.  
 Do not alter design viscosity without prior approval from factory.

TEMPERATURE: ..... Type B: 0-160°F,  
 Type H: 0-250°F at 1800 RPM or less, 0-225°F above 1800 RPM,  
 Type F: 0-250°F  
 Consult factory for allowable temperatures for alternate seal arrangements.

INLET PRESSURE: .. Types B and H - 75 PSIG nominal maximum  
 Type F - 10 PSIG nominal maximum  
 Consult factory for minimum required inlet pressure.  
 Special modifications for up to 250 PSIG.

DRIVE: ..... Direct, belt or chain (Type F - direct only)

FILTRATION: ..... Light fluids - 60 mesh  
 Heavy fluids - 1/8 to 3/16-inch

MOUNTING: ..... Foot or flange mounted in any attitude

## G. PARTS LIST

Table 5

### LIST OF MATERIALS (FIGURES 18 THROUGH 22)

ITEM	KIT	DESCRIPTION	ITEM	KIT	PART DESCRIPTION
001		Case	024		Lockwasher (2)
002	XX	Housing	025	X	Mechanical Seal
003		Plug	026		Inlet Head or Clamp Ring
003		Capscrew or Bolt	027		Spacer
004	XX	Tube	028		Nameplate
005	X	O-ring (2)	029		Drive Screw *
006	X	O-ring	030		Lockwasher
007	X	O-ring	031	X	Gasket
008	X	O-ring or Gasket	031		Capscrew (4)
009	XX	Inboard Cover	032		Plug
010		Capscrew or Bolt **	035	XX	Truarc Ring
011	XX	Power Rotor	035	X	Gasket
013	X	Truarc Ring (2)	036	X	Gasket
014	XX	Spacer	039		Check Valve
015	X	Ball Bearing	042		Tubing
016		Key	043		Spring Pin
017		Retainer	043		Spacer
018		Bolt (4)	044	X	O-ring
019	XX	Idler (2)	045	X	Dyna Seal
020	XX	Idler cups (2)***	046		O-ring
021	XX	Thrust Plate	046	X	Stop Pin
022		Spacer (2)	047	XX	Balance Piston Housing
023		Bolt or Stud (2)			

(X) Minor Repair Kit items  
 (XX) Major Repair Kit items. Items marked (X) also included in Major Repair Kit.

Quantities are one (1) except when noted in parentheses after part description or noted below.

\* Quantity is three (3) for Figure 13 pumps.

\*\* Based on Inboard Cover and Inlet Head design, quantity can be four (4), eight (8) or Sixteen (16).

\*\*\* Note: Some Idlers have a hydrostatic thrust design and do not need idler cups (21).



**Table 6**

**LIST OF MATERIALS (FIGURES 23 AND 24)**

ITEM	KIT	DESCRIPTION	ITEM	KIT	PART DESCRIPTION
001		Case	022	XX	Thrust Plate
002	XX	Housing	023		Spacer (2)
003		Plug	024		Bolt (2)
004		Tube	025		Lockwasher (2)
005	X	O-ring (2)	026		Inlet Head
006	X	O-ring	027		Key
007	X	O-ring	028		Elbow (2)
008	X	Gasket	029		Nipple (2)
009	XX	Inboard Cover	030	XX	Check Valve
010	XX	Capscrew (2)	031		Tubing
011		Bolt (8)	032		Tee
012	XX	Power Rotor	033		Nameplate
014	X	Balance Piston Housing	034		Drive Screw (3)
015		Spacer	035		Plug
016	X	Packing	036		Elbow
017		Packing Gland	037		Spring Pin (2)
018		Gland Screw (2)	038		Nut (2)
019		Washer (2)	039		Nipple
020	XX	Idler (2)	040		Nipple
021	XX	Idler Cups***			
(X) Minor Repair Kit items					
(XX) Major Repair Kit items. Items marked (X) also included in Major Repair Kit.					
Quantities are one (1) except when noted in parentheses after part description.					

\*\*\* Note: Some Idlers have a hydrostatic thrust design and do not need idler cups (21).

## H. PUMP MAINTENANCE



### WARNING

Failure to observe precautions while installing, inspecting and maintaining pump can cause injury to personnel from accidental handling of liquids that may harm skin or clothing, or fire hazard risks from flammable liquids, or injury from high pressure fluid jets.



### DANGER

**BEFORE** working on equipment, make sure all power to equipment is disconnected and locked-out.

### H.1 GENERAL COMMENTS

**NOTE:** Part number identifiers (IDP) contained within parenthesis such as (9) refer to circled numbers shown on assembly drawings (figures 2 through 4).

De-energize driver before starting with any maintenance action.

### H.2 TOOLS REQUIRED

Procedures described in this manual require common mechanics hand tools, a torque wrench, dial indicators for alignment and a suitable lifting device, such as slings, straps, etc.

### H.3. DISASSEMBLY AND ASSEMBLY PROCEDURES (MECHANICAL SEAL PUMPS)



### CAUTION

Fluid leakage from disassembly of pump may make the floor slippery and can cause personal injury

#### Disassembly Procedures For (Figures 18 through 21)

**NOTE:** Refer to pump assembly drawings, figures 18 through 22; inlet head arrangements, Figure 26, special inboard cover construction, Figure 25, and mechanical seal drawings and assembly drawings, Figures 2 through 17, during pump disassembly. Refer to Table 1 for proper mechanical seal identification. Disassembly procedures for all G3D pumps with mechanical seals are identical except when specifically noted.

Close off suction and discharge piping to pump and disconnect piping. If applicable, remove tubing (042, Figure 20) with check valve (039). (Must be reinstalled in original installed position.) Remove drain plugs and drain unit. Remove pump from driver, coupling and mounting bracket. Remove coupling hub and key (016).

1. Remove capscrews (010) or bolts (010) with lockwashers (030), if applicable, and remove inlet head (026) from case (001).

**NOTE:** If no inlet head is used, (Figure 26, Arrangement C) remove clamp ring (026).

2. Remove gasket (008) from case (001) or O-ring (008) from inlet head (026).
3. Remove bolts (023) or jam nuts (047) from studs (023) and lockwashers (024).
4. Remove thrust plate (021) and spacers (022). If installed, remove O-rings (046) from studs (023, Figure 21).
5. Remove idler cups (020), where applicable.\*
6. Remove idlers (019) by unscrewing idlers from housing (002) idler bores.

<b>CAUTION</b>	<b>ATTENTION</b>
Do not permit idlers (019) to drop as they emerge from housing (002).	

7. Remove bolts (018) and bearing retainer (017).
8. Pull assembled power rotor (011) from case (001). **NOTE:** Removal of assembled power rotor (011) includes removal of truarc rings (013), ball bearings (015) and spacer (014). If installed, mechanical seal (025) and truarc ring (035) will also be removed with assembled power rotor (011).
9. On pumps equipped with mechanical seal (025), remove gasket or O-ring from mechanical seal bore of cover (009).
10. Remove capscrews (010, 003 or 031) or bolts (010 or 003) and remove inboard cover (009) from case (001).
11. (Figures 18 through 21) Remove O-ring (007) from inboard cover (009)  
**NOTE:** If installed, lockwashers (030) will be removed with bolts (010).
12. Remove tube (004) with O-rings (005) and spacer (027) from either inboard cover (009) or housing (002).  
**NOTE:** Spacer (027) not installed on rotor size 312 pumps.
13. Remove O-rings (005) from tube (004). Remove O-rings (007) from case (001).
14. Remove housing (002) with O-ring (006) from inlet end of case (001). Remove O-ring (006) from housing (002).
15. Disassembly power rotor (011) as follows
  - (a) Remove outer truarc ring (013).
  - (b) Using a bearing puller or press, remove ball bearing (015).
  - (c) Remove inner truarc ring (013).
  - (d) Remove spacer (014).

**NOTE:** Based on mechanical seal design, removal of spacer (014) can remove mechanical seal stationary assembly.

\* Note: Some idlers have a hydrostatic thrust design and do not use idler cups (020).

**NOTE:** Power rotor (011) with balance piston is a sub-assembly. Do not remove balance piston as parts are not sold or serviced separately.

(e) Remove mechanical seal. Refer to Mechanical Seal Disassembly procedures for removal of stationary assembly (1 and 2) and rotating assembly (3).

(f) If applicable, remove truarc ring (035) or shim (051).

**NOTE:** Balance piston (012) furnished as part of power rotor (011) and bushing (033) furnished as part of inboard cover (009) and are not serviced separately when used on specific pump types.

### **Assembly Procedures (Figures 18 through 21)**

**NOTE:** Prior to assembly of pump, all parts should be cleaned and inspected for nicks and burrs. Replace all worn or damaged parts. Imo Pump recommends automatic replacement of gaskets, O-rings, mechanical seals and ball bearings when these parts are disturbed from their previously installed position. Refer to pump assembly drawings, Figures 18 through 22, inlet head arrangements Figure 26, special inboard construction, Figure 25, mechanical seal drawings and assembly drawings, Figures 2 through 17, and List of Material, Table 5, during pump assembly. Coat all parts with SAE-30 oil to assist in assembly. Assembly procedures for all G3D pumps with mechanical seals are identical except when specifically noted.

1. Install O-ring (006) into groove of rotor housing (002). Install O-rings (005) on tube (004) and install tube (004) in housing (002).
2. (Figures 18 through 21) Install housing (002), O-ring end first, in inlet end of case (001) until housing (002) is flush with inlet end of case (001). Align spacer (027) with tube (004) and install spacer (027) in case (001).

**NOTE:** Spacer (027) not installed on rotor size 312 pumps.

3. (Figures 18 through 21) Install O-ring (007) on inboard cover (009).
4. Install inboard cover (009) on case (001). NOTE: Ensure that tube (004) enters inboard cover (009) tube bore.
5. Install capscrews or bolts (003, 010 or 031) and torque bolts or capscrews (003 or 010) to proper value as given in Table 3.

**NOTE:** If installed, lockwashers (030) will be installed with bolts (010).

**Table 3  
TORQUE VALUES - MECHANICAL SEAL PUMPS**

PART	ROTOR SIZE	TORQUE VALVE	PART	ROTOR SIZE	TORQUE VALVE
010 and 031 <sup>(1)</sup>	187	35 lbs. ft. (± 5 lbs. ft.)	018	187	18 lbs. ft. (± 2 lbs. ft.)
	218	55 lbs. ft. (± 5 lbs. ft.)		218	20 lbs. ft. (± 2 lbs. ft.)
	250	70 lbs. ft. (± 5 lbs. ft.)		250	20 lbs. ft. (± 2 lbs. ft.)
	312	78 lbs. ft. (± 5 lbs. ft.)		312	38 lbs. ft. (± 2 lbs. ft.)
010 <sup>(2)</sup>	187	90 lbs. ft. (± 5 lbs. ft.)	023	187	10 lbs. ft. (± 2 lbs. ft.)
	218	75 lbs. ft. (± 5 lbs. ft.)		218	15 lbs. ft. (± 2 lbs. ft.)
	250	145 lbs. ft. (± 5 lbs. ft.)		250	15 lbs. ft. (± 2 lbs. ft.)
	312	78 lbs. ft. (± 5 lbs. ft.)		312	30 lbs. ft. (± 2 lbs. ft.)
003	187	20 lbs. ft. (± 2 lbs. ft.)	047	312	30 lbs. ft. (± 2 lbs. ft.)
	218	20 lbs. ft. (± 2 lbs. ft.)			
	250	20 lbs. ft. (± 2 lbs. ft.)			
(1) Part Number 010 or 031 installed in inboard cover (009).					
(2) Part Number 010 installed in inlet head (026).					

6. Assemble power rotor (011) as follows:

- NOTE:** For pumps with no mechanical seal, proceed to Step 6 (d).
- (a) Install truarc ring (035, Figures 12 and 14) or shim (051, Figure 11, rotor size 312).
  - (b) Install mechanical seal (025) rotating assembly (3, Figures 2 through 10).
  - (c) Install mechanical seal (025) stationary assembly (1 and 2, Figures 2 through 10) on power rotor or in spacer (014) based on seal design.
  - (d) Install spacer (014) and inner truarc ring (013).
  - (e) Install ball bearing (015) by pressing on inner race only of ball bearing (015). NOTE: Inner race of ball bearing (015) should be positioned next to truarc ring (013).
  - (f) Install truarc ring (013) next to ball bearing (015) in outer ring groove of power rotor (011).
7. On pumps equipped with mechanical seal, install gasket or O-ring in mechanical seal bore of cover (009).
  8. Install assembled power rotor (011), centering all parts, in case (001).
  9. Install retainer (017) using bolts (018). Torque bolts (018) to proper value given in Table 3.
  10. Install idlers (019) into housing (002) idler bores by turning idlers (019) while inserting them into housing.
  11. Install cups (020) on idlers (019), where applicable. \*
- \* Note: Some idlers have a hydrostatic thrust design and do not need idler cups (20).
12. Install spacers (022), thrust plate (021), lockwashers 24 and bolts (023) or jam nuts (047). Torque bolts (023) or jam nuts (047) to proper value given in Table 3.
  13. . Install O-ring (008) on inlet head (026) or gasket (008) on case (001). Install inlet head (026) or clamp ring (026, Figure 26, Arrangement C) using capscrews or bolts (010). Torque capscrews or bolts (010) to correct value given in Table 3. NOTE: If installed, lockwashers (030) will be installed with bolts (010).

\* Note: Some idlers have a hydrostatic thrust design and do not use idler cups (020)

14. Install key (016) and coupling hub on power rotor (011).
15. Install drain plugs if removed during disassembly.
16. If applicable, connect tubing (042, Figure 20) ensuring that check valve (039) is installed in original position
17. Connect pump to mounting bracket and coupling. Align pump with driver as described in CA-1 manual.

## **MECHANICAL SEALS**

Mechanical seals installed in Series G3D pumps are Type 2, Figures 2 and 3: Type 8-1, Figures 4 and 5: Type 21, Figures 6 and 7: Type 8B3, Figure 8: Type 9B3, Figure 9; Type BX, Figure 10; and Flexibox and Sealol, not illustrated. Disassembly and assembly procedures for mechanical seals are as follows:

### **DISASSEMBLY**

#### ***Stationary Assembly:***

- A. **(Figures 2, 4, 6 and Flexibox)** Slide stationary assembly, seat (1) and gasket (2) off power rotor shaft.
- B. **(Figures 3, 5, 7, 8, 9, 10 and Sealol)** Stationary assembly, seat (1) and O-ring (2), is removed with spacer (014) from power rotor shaft. Remove stationary assembly from spacer (014).

#### ***Rotating Assembly:***

- A. **(Figures 2, 3, 6, 7 and Flexibox)** Slide rotating assembly (3) off power rotor shaft. NOTE: Use a piece of shim stock for removal of Figure 11 to avoid damage to power rotor.
- B. **(Figures 4, 5, 8, 9, 10 and Sealol)** Loosen setscrews and slide rotating assembly off power rotor shaft.

### **ASSEMBLY**

#### ***Rotating Assembly:***

The rotating assembly (3) is normally packaged as an assembly for ease of installation. Ensure that all O-rings are properly positioned in assembly prior to installation. Coat all parts of the seal with oil prior to assembly on power rotor shaft. Refer to mechanical seal drawings, Figures 2 through 10, and mechanical seal assembly drawings, Figures 11 through 17, for applicable assembly procedures.

- A. **(Figures 2, 3, 6, 7 and Flexibox)** Slide rotating assembly (3) on power rotor shaft next to piston (012, Figures 11 and 13), truarc ring or spacer (035, Figures 12 and 14).

**NOTE:** Use a piece of shim stock under split sleeve of Flexibox seal to avoid damage to power rotor.

- B. Remove and discard retaining clips (4) prior to final tightening of setscrews (3F).
- C. **(Figures 2 through 10)** Install mechanical seal seat (1) and O-ring (2) in spacer (014, Figures 13, 15 and 16). Ensure that spring pin is properly positioned to engage slot in seal seat. Slide spacer (014) on power rotor. Install inner truarc ring (013) in power rotor groove. Press ball bearing (015) on power rotor, pressing only on inner race of ball bearing (015). Install outer truarc ring (013) in power rotor groove.

## Figures 2 through 10 Mechanical Types

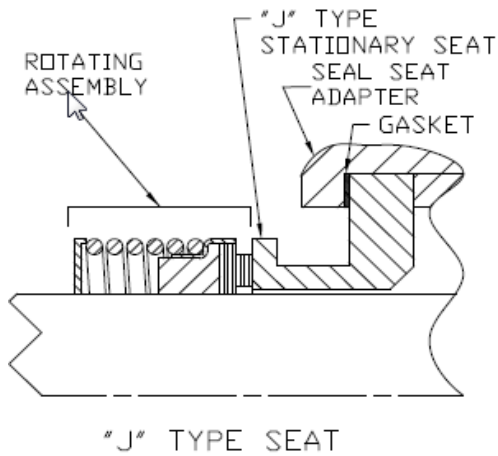

Figure 2. Type 2 Single Mechanical Seal Clamped or "J" Seat Type

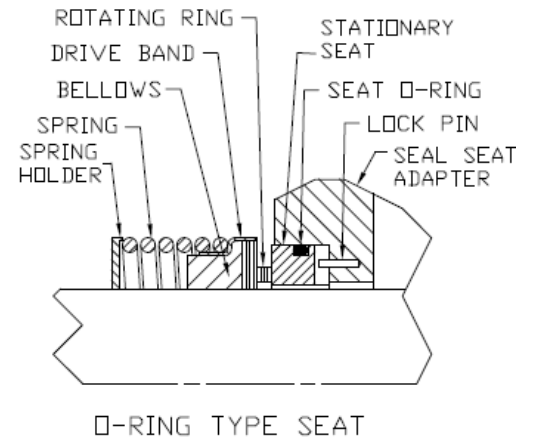

Figure 3. Type 2 Single Spring Mechanical Seal O-Ring Seat Type

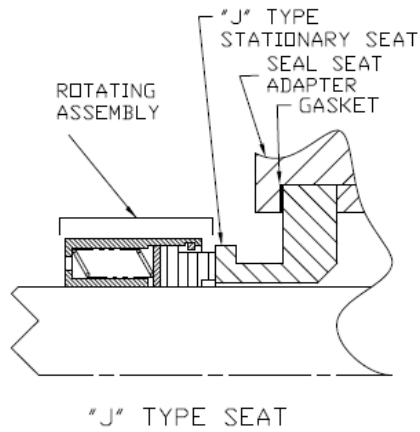

Figure 4. Type 8-1 Multi Spring Mechanical Seal Clamped or "J" Seat Type

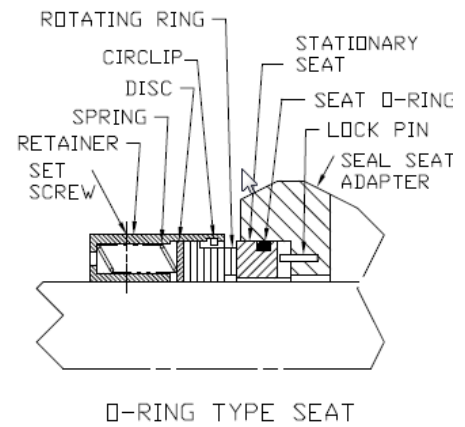

Figure 5. Type 8-1 Multi Spring Mechanical Seal O-Ring Seat Type

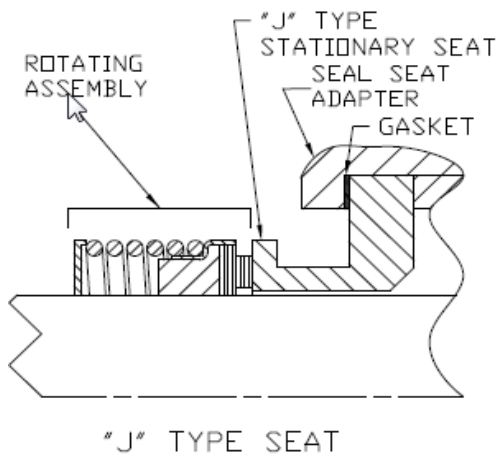

Figure 6. Type 21 Single Mechanical Seal Clamped or "J" Seat Type

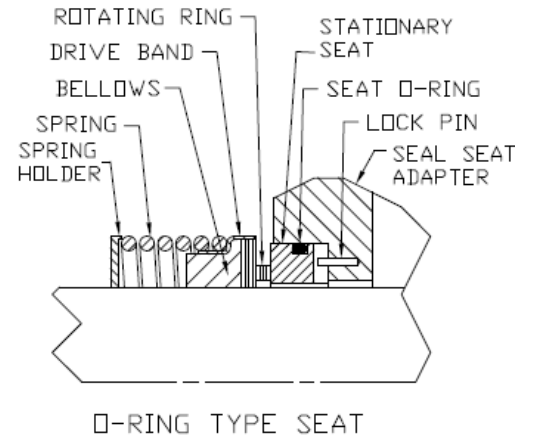

Figure 7 Type 21 Single Spring Mechanical Seal O-Ring Seat Type

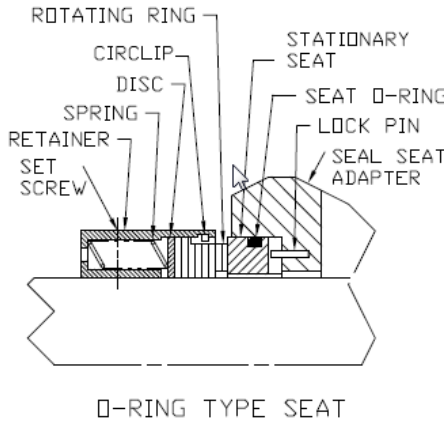

Figure 8. Type 8B3 Multi Spring Mechanical Seal O-Ring Seat

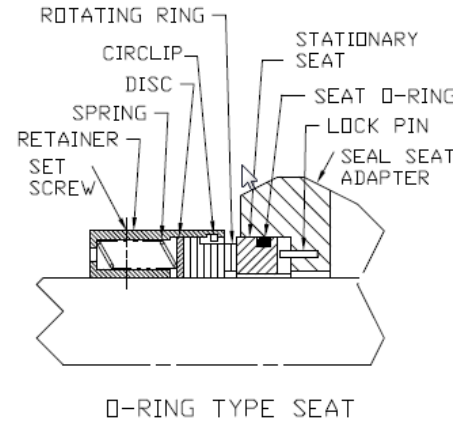

Figure 9. Type 8B3 Multi Spring Mechanical Seal O-Ring Seat Type



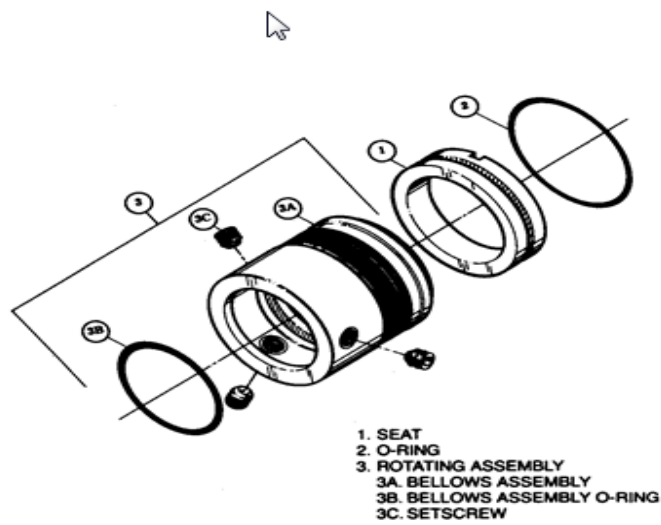

Figure 10. Type BX Mechanical Seal

Figures 11 through 17 Mechanical Seal Information

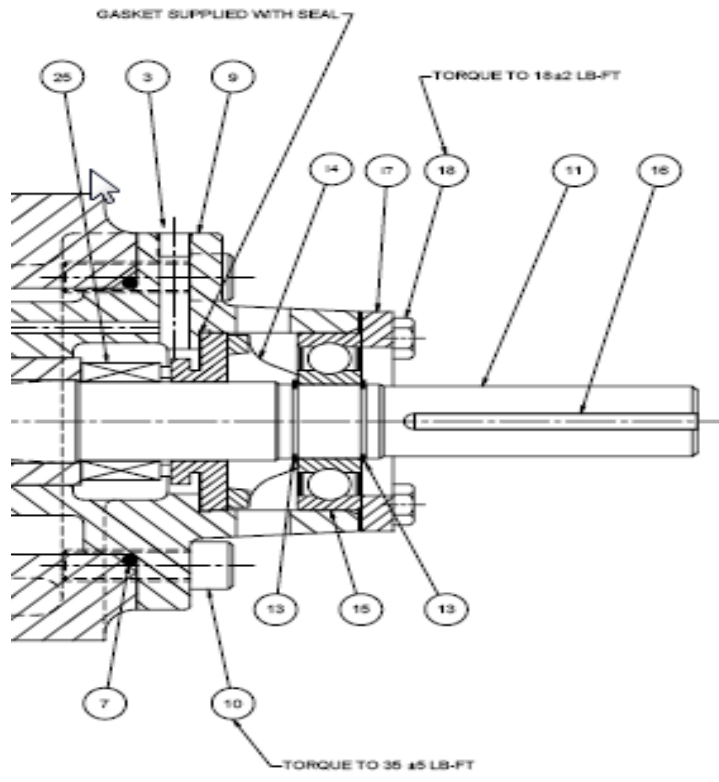
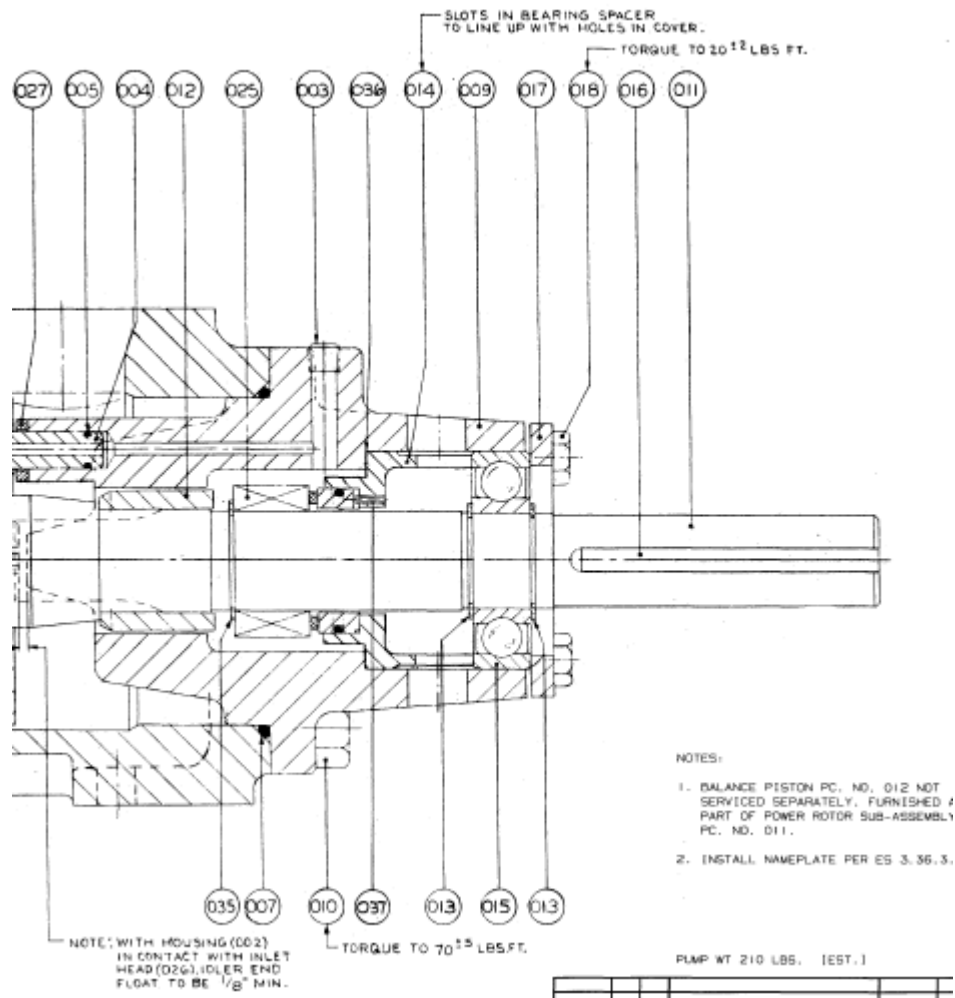
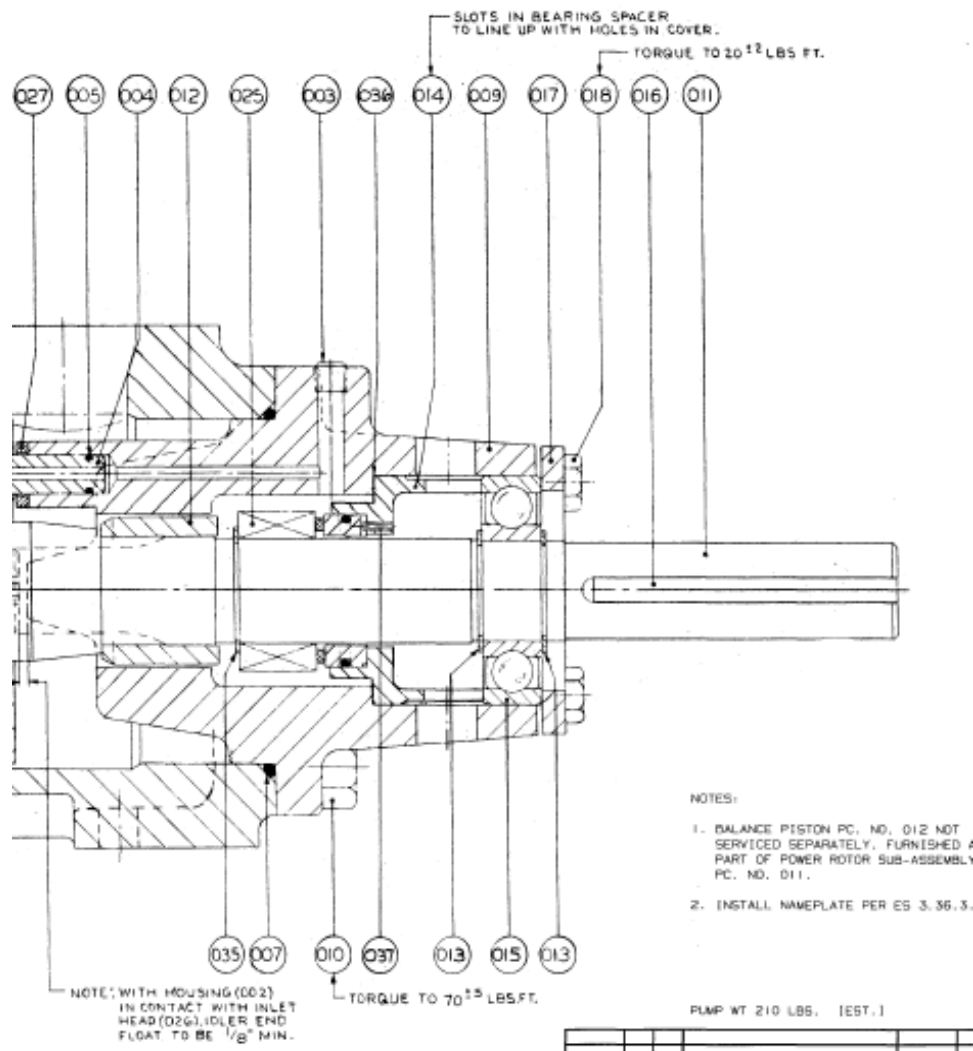

Figure 11. Type 2, Clamped Seat (Rotor Size 187) Type 8-1 and 21, Clamped Seat (187, 218, and 312) Flexbox Rotor Size



**Figure 12. Type 2, 8-1 O-ring Seat (Rotor Size 250)**



**Figure 13. Type 2 O-ring Seat (Rotor Size 187 and 218) Type 8-1 and 21, O-ring Seat (rotor Size 187 and 218), Sealot (Rotor Size 187), Type 8B3 (Rotor Size 187, 218, 312)**

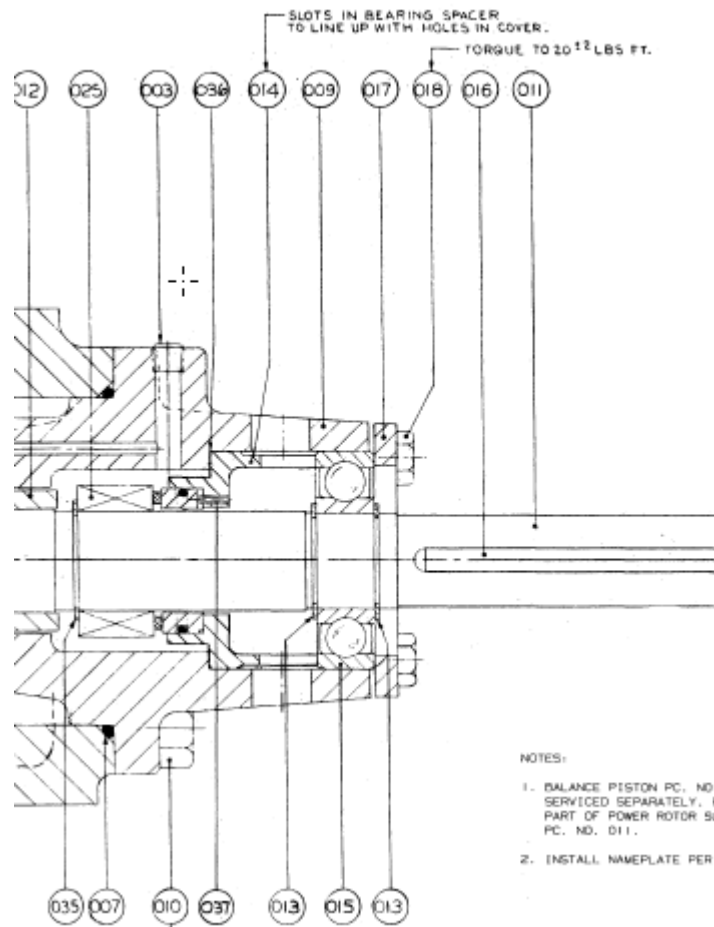

**Figure 14. Type 2, 81 and O-ring Seat (Rotor Size 250)**

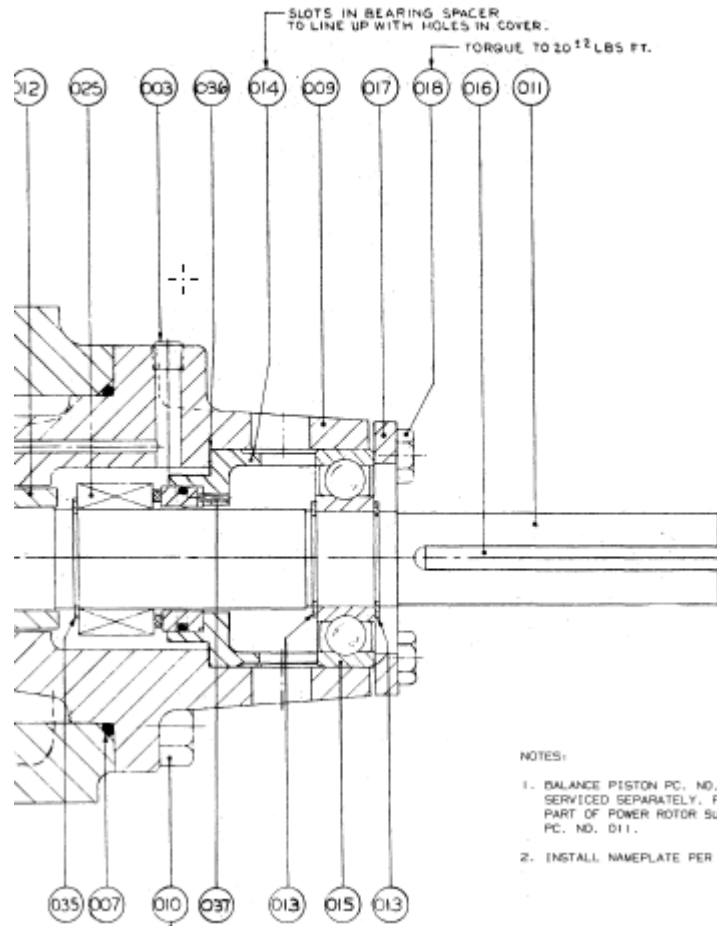

Figure15. Type BX (Rotor Size 187 through 250)

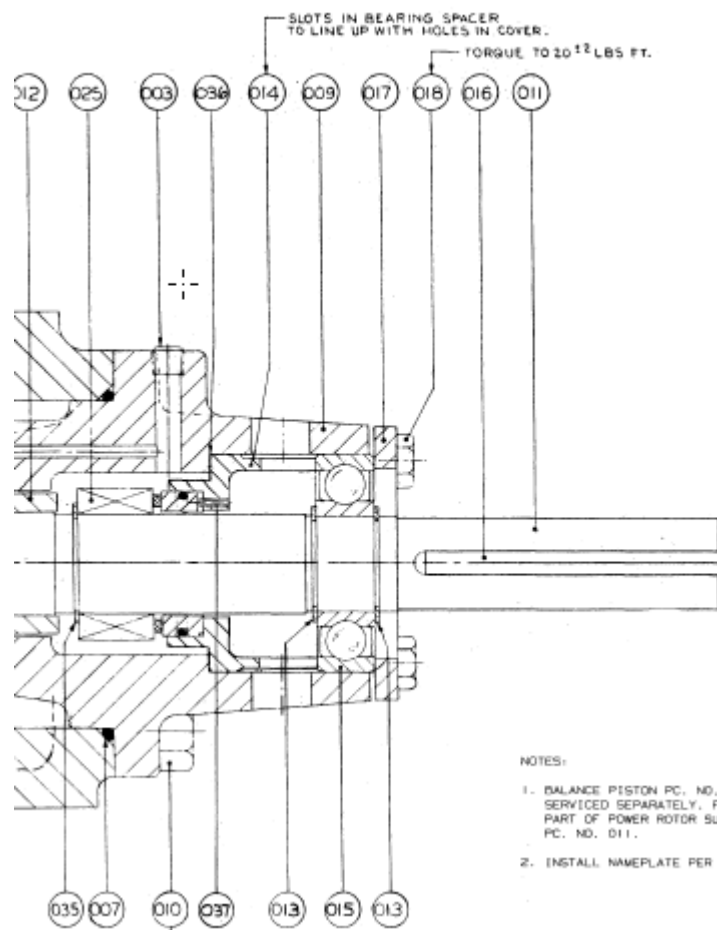

Figure16. Type 9B3 (Rotor Size 187)

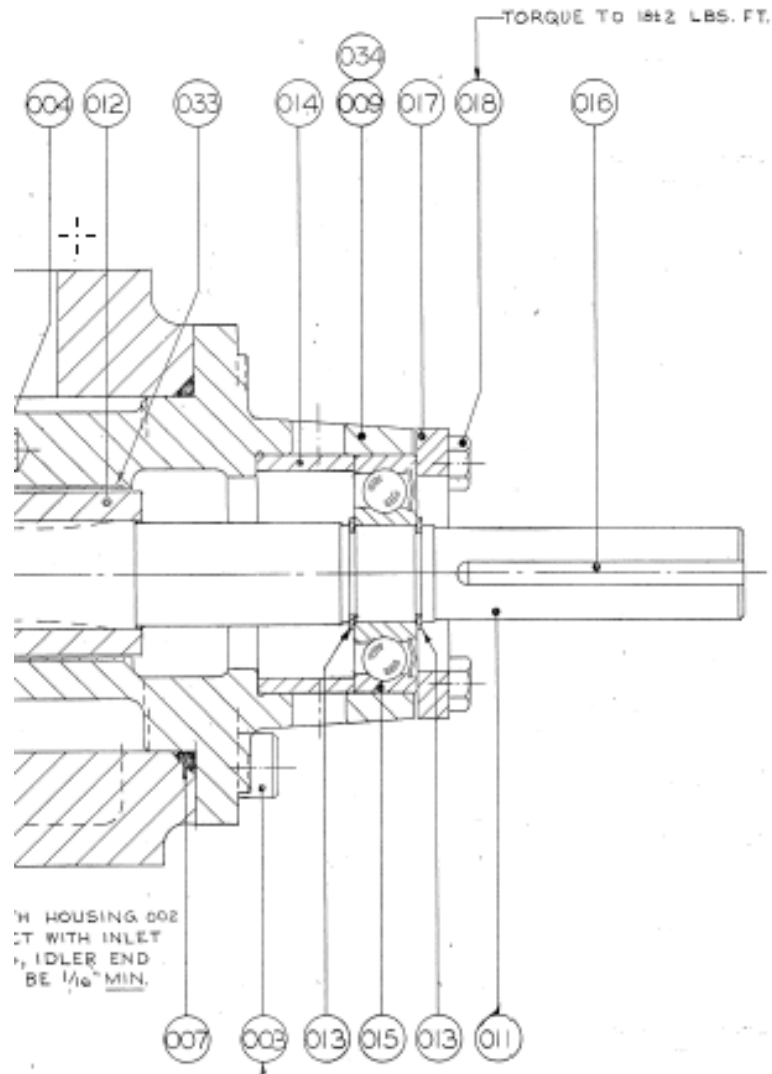

Figure 17. No Seal (Rotor Sizes 187 through 312)

## DISASSEMBLY AND ASSEMBLY PROCEDURES (PACKING PUMPS)

### Disassembly Procedures (Figures 23 and 24)

**NOTE:** Refer to pump assembly drawings, Figures 23 and 24, during pump disassembly. Disassembly procedures for Figures 23 and 24 packing pumps are identical.

1. Close off suction and discharge piping to pump and disconnect piping. Remove tubing (031) from pump, ensuring that tubing (031) is not bent or flattened. Remove drain plugs (003). Remove pump from driver, coupling and mounting bracket. Remove coupling hub and key (027).
2. Remove bolts or capscrews (011) and inlet head (026) and gasket (008).
3. Remove bolts (024) with lockwashers (025), thrust plate (022) and spacers (023).
4. Remove idler cups (021), where applicable. \*
5. Remove idler rotors (020) by unscrewing idlers (020) from housing (002) bores.
6. Loosen packing gland nuts (038) or capscrews (018) to relieve pressure on packing gland (017).
7. Remove capscrews or bolts (011). Pull assembled power rotor (012) from case (001).

**NOTE:** Removal of assembled power rotor will remove packing gland (017), packing (016), inboard cover (009), balance piston housing (014), tube (004) with O-rings (005), spacer (015) and O-ring (007).

8. Remove gland nuts (038) or screws (018), washers (019) and packing gland (017) from power rotor (012).
9. Using a "packing puller" or sharp pointed brass or copper rod, remove packing (016)
10. Remove capscrews (010) and remove inboard cover (009) with O-ring (007) from power rotor (012).
11. Remove balance piston housing (014) with tube (004) and spacer (015) from power rotor (012). Remove spacer (015) from tube (004) and remove tube (004) with O-rings (005) from balance piston housing (014). Remove O-rings (005) from tube (004).

**NOTE:** If tube (004) is not removed with power rotor assembly (012), it will be removed from housing (002).

**NOTE:** Balance piston (013) furnished as part of power rotor (012) and not serviced separately.

12. Remove housing (002) with O-ring (006) from inlet end of case (001). Remove O-ring (006) from housing (002).

### Assembly Procedures (Figures 23 and 24)

**NOTE:** Prior to assembly of pump, all parts should be cleaned and inspected for nicks and burrs. Replace all worn or damaged parts. Imo Pump recommends automatic replacement of O-rings, gasket, and packing when these parts are disturbed from their previously installed position. Refer to pump assembly drawings, Figures 23 and 24, and List of Material, Table 7, during pump assembly. Coat all parts with SAE-30 oil to assist in assembly. Assembly procedures for Figures 23 and 24 pumps are identical.

1. Install O-ring (006) on housing (002). Install housing (002), O-ring end first, in inlet end of case (001) until housing (002) is flush with inlet end of case (001).
2. Install O-rings (005) on tube (004) and install tube (004) in housing (002). Install spacer (015) on tube (004).



**Table 4**  
**TORQUE VALUES - PACKING PUMPS**

PART	ROTOR SIZE	TORQUE VALUE	PART	ROTOR SIZE	TORQUE VALUE
011(1)	187	35 lbs. ft. (± 5 lbs. ft.)	010	218	30 lbs. ft. (± 5 lbs. ft.)
	218	55 lbs. ft. (± 5 lbs. ft.)		250	30 lbs. ft. (± 5 lbs. ft.)
	250	70 lbs. ft. (± 5 lbs. ft.)			
011(2)	187	90 lbs. ft. (± 5 lbs. ft.)	024	187	10 lbs. ft. (± 2 lbs. ft.)
	218	75 lbs. ft. (± 5 lbs. ft.)		218	15 lbs. ft. (± 2 lbs. ft.)
	250	145 lbs. ft. (± 5 lbs. ft.)		250	15 lbs. ft. (± 2 lbs. ft.)
(1) Part Number Oil installed in inboard cover (009).					
(2) Part Number Oil installed in inlet head (026).					

3. Install inboard cover (009) on power rotor (012). Install balance piston housing on power rotor (012) and install capscrews (010). Torque capscrews (010) to proper value listed in Table 4.

4. Install O-ring (007) on inboard cover (009).

5. Install assembled power rotor (012) in case (001).

**NOTE:** Ensure that tube (004) enters balance piston housing (014) tube bore

6. Install bolts or capscrews (011) in inboard cover (009). Torque bolts or capscrews (011) to proper value listed in table 4.

7. Install idlers (020) into housing (002) idler bores by turning idlers (020) while inserting them into housing (002).

8. Install idler cups (021) on idlers (020), where applicable.\*

9. Install spacers (023), thrust plate (022), lockwashers (025) and bolts (024). Torque bolts (024) to proper value given in Table 4.

10. Install gasket (008) and inlet head (026) using bolts or capscrews (011). Torque bolts or capscrews (011) to proper value listed in Table 4.

11. Install packing (016) in packing bore of inboard cover (009). Joints of packing (016) rings to be staggered and hard and soft rings alternately inserted, beginning with a hard ring.

12. Install packing gland (017). Install gland nuts (038) or screws (018) with washers (019). Tighten nuts (038) or screws (018) hand tight.

13. Install key (027) and coupling hub on power rotor (012).

14. Install drain plugs (003). Replace tubing (031) and fittings in proper position.

\* **Note:** Some Idlers have a hydrostatic thrust design and do not need idler cups (21).

15. Connect pump to mounting bracket and coupling. Align pump with driver as described in CA-1 manual.

**CAUTION****ATTENTION**

When starting pump, adjust packing seepage to allow seepage of four to eight drops per minute. DO NOT over-tighten packing. Seepage from packing gland provides cooling and lubrication of packing.

## **I. TROUBLESHOOTING**

For assistance with troubleshooting see the General Instruction Manual, CA-1.

## **J. FIELD AND FACTORY SERVICE AND PARTS**

Imo Pump maintains a staff of trained service personnel that can provide pump installation, pump start-up, maintenance/overhaul and troubleshooting supervision as well as installation and maintenance training.

Our factories provide maintenance as well as overhaul and test facilities the in event the user prefers to return pumps for inspection or overhaul. Factory-overhauled pumps are normally tested and warranted “as-new” for a period of one year from date of shipment. For either field service or factory overhaul assistance, contact your local Imo Sales Office or representative at Technical/ Customer Service Department in Monroe, NC, USA.

Most pumps have repair kits available. Minor Repair Kits are used to repair leaking seals, bad bearings and/or for re-assembly after pump tear-down. They include (as applicable) pump shaft seals, packing, all gaskets/O-rings and bearings. Major Repair Kits are sufficient to rebuild completely worn-out pumps to “as-new” condition. They include all parts found in Minor Repair Kits plus all major internal parts subject to wear. Since kits have all necessary parts, kit purchase is preferred rather than selecting individual parts. When parts are individually selected from Parts List, some needed components are often overlooked. In addition, mixing worn or used parts with new parts risks rapid wear and shortened service life from new parts.

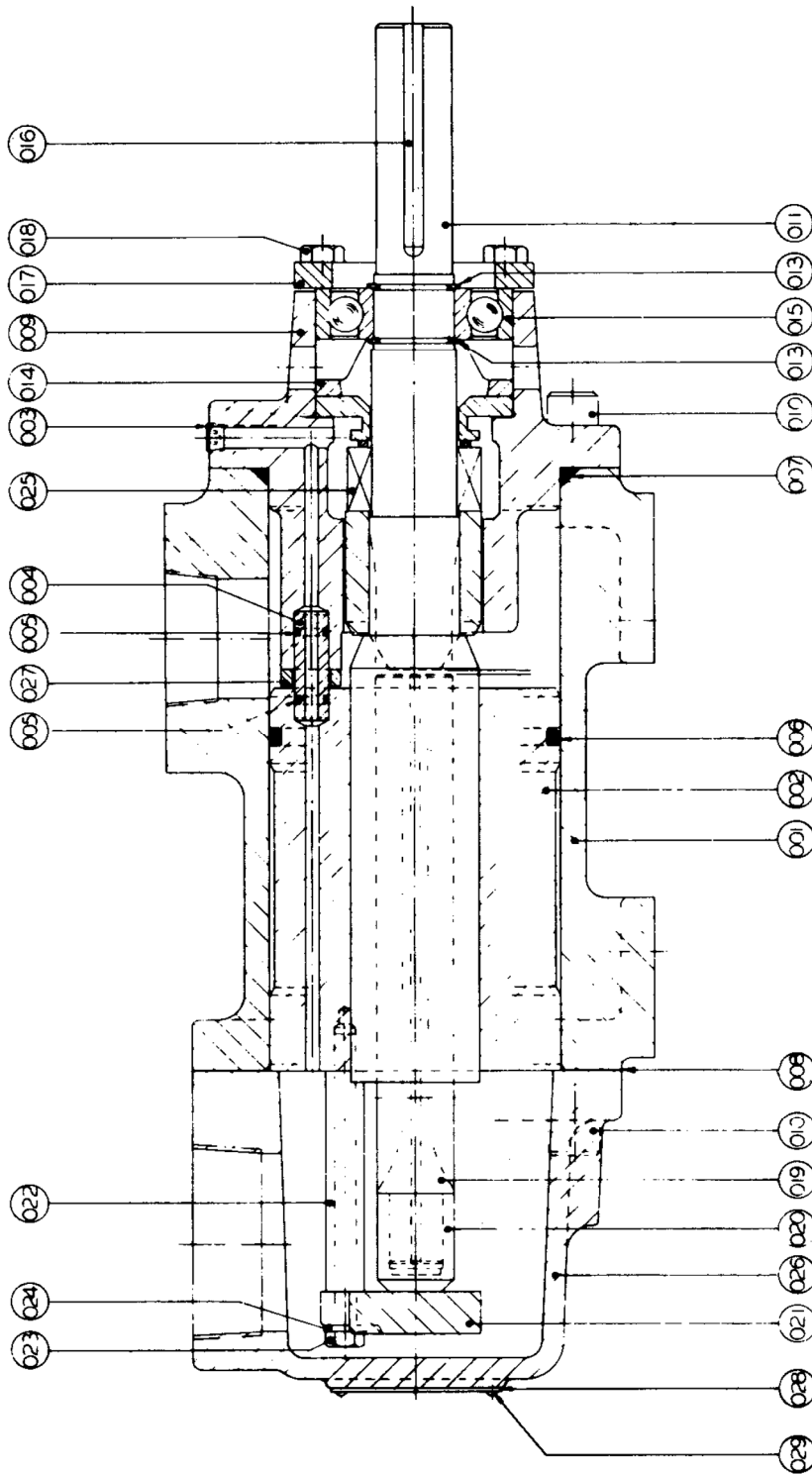

**Figure 18. Rotor Size 187**

**Note: Idler Cups (20) not required on some designs.**

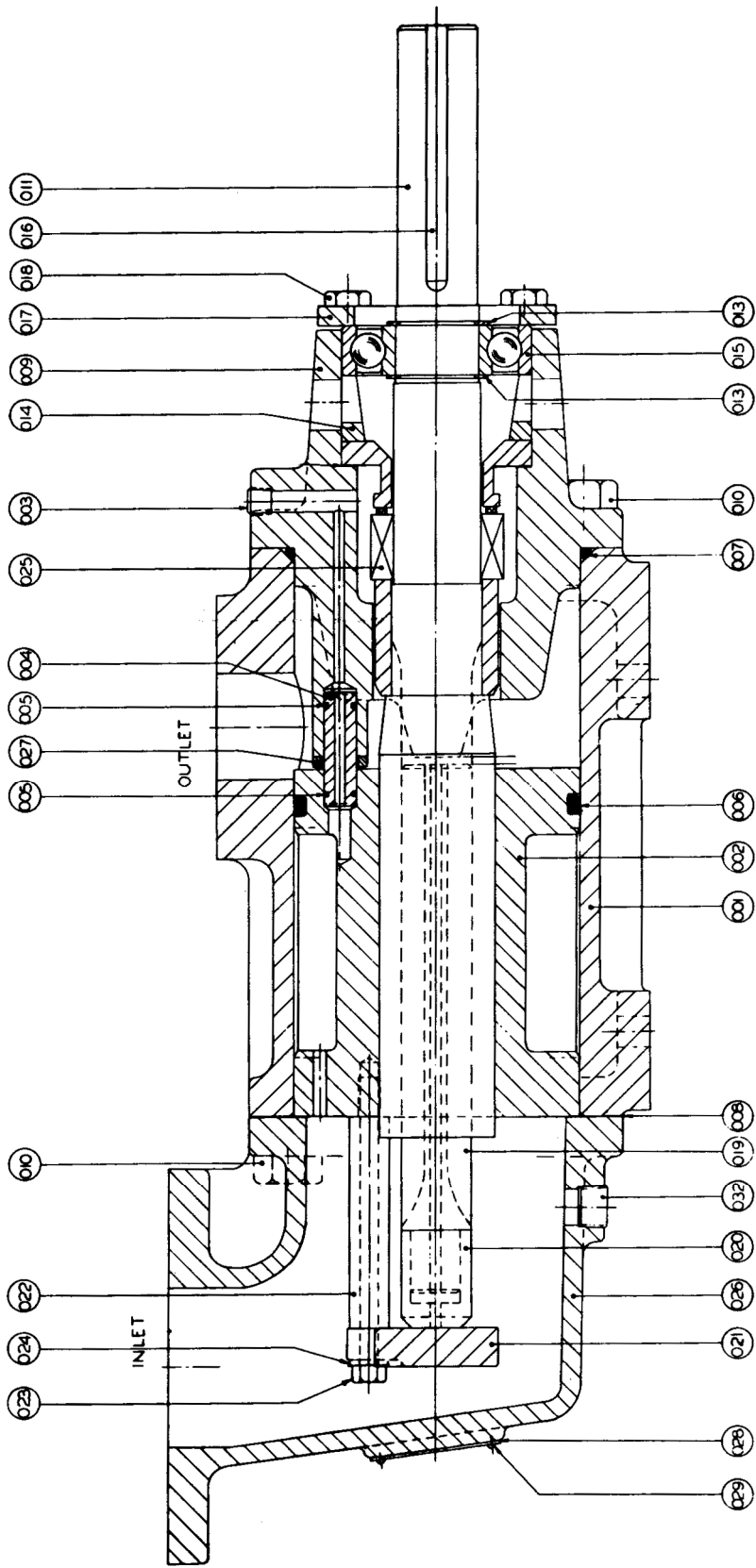
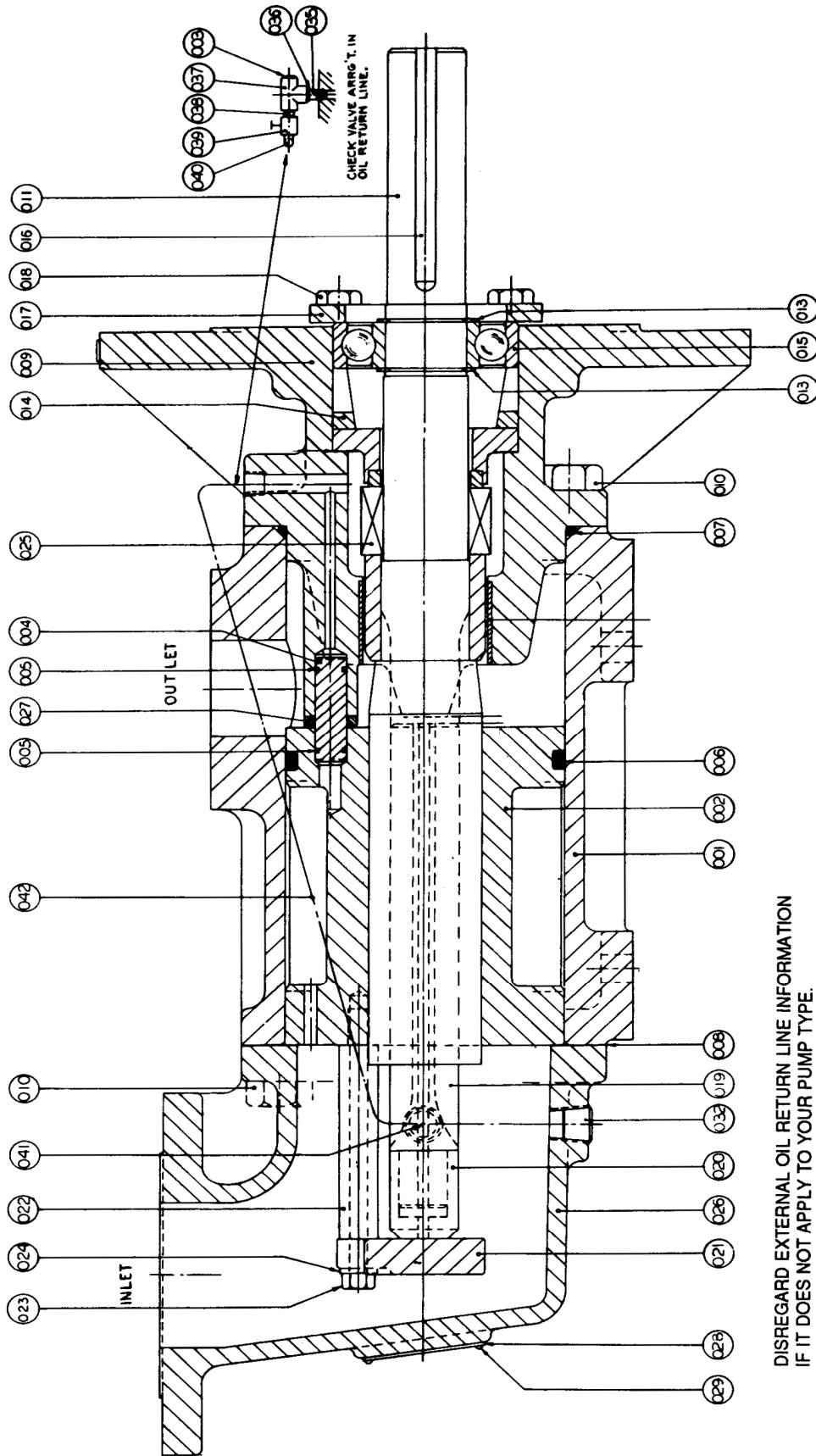

Figure 19. Rotor Sizes 218 and 250

Note: Idler Cups (20) not required on some designs.



DISREGARD EXTERNAL OIL RETURN LINE INFORMATION  
IF IT DOES NOT APPLY TO YOUR PUMP TYPE.

Note: Idler Cups (20) not required on some designs.

Figure 20. Rotor Sizes 218 and 250 (Vertical Mount, Oil Return Line from Seal Chamber)

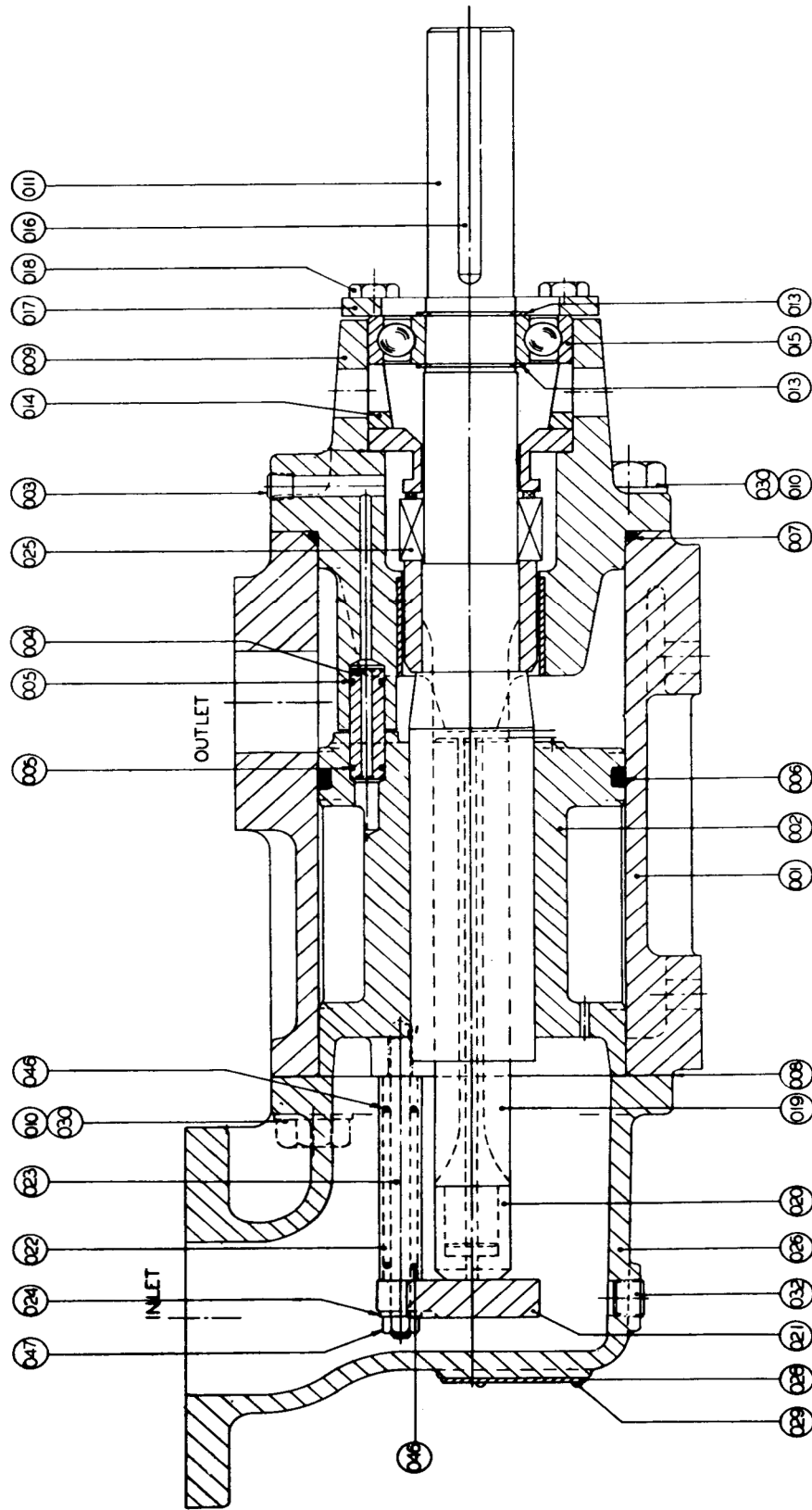

**Note: Idler Cups (20) not required on some designs.**

**Figure 21. Rotor Sizes 312**

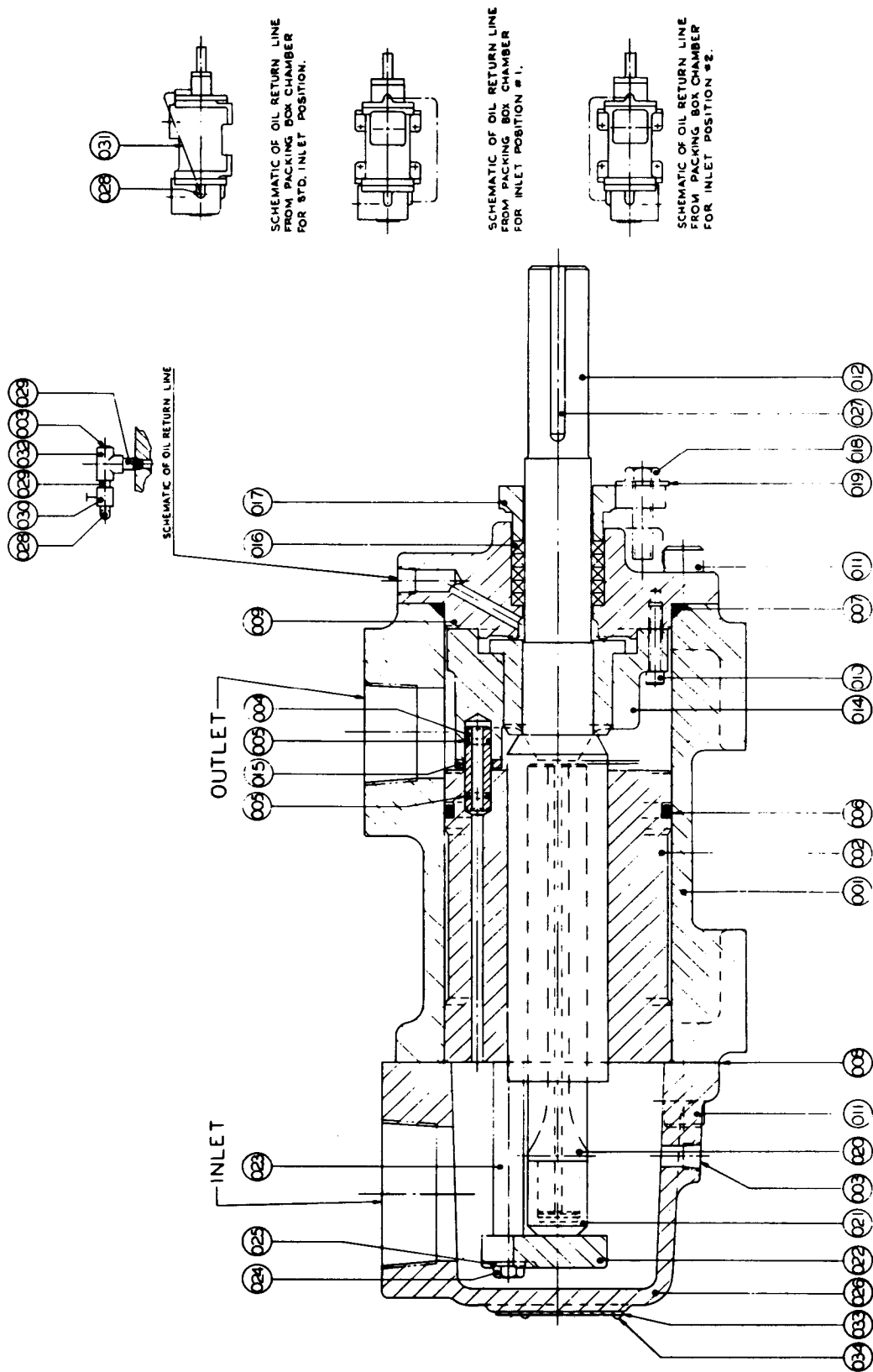

Note: Idler Cups (20) not required on some designs

Figure 23. Rotor Size 187

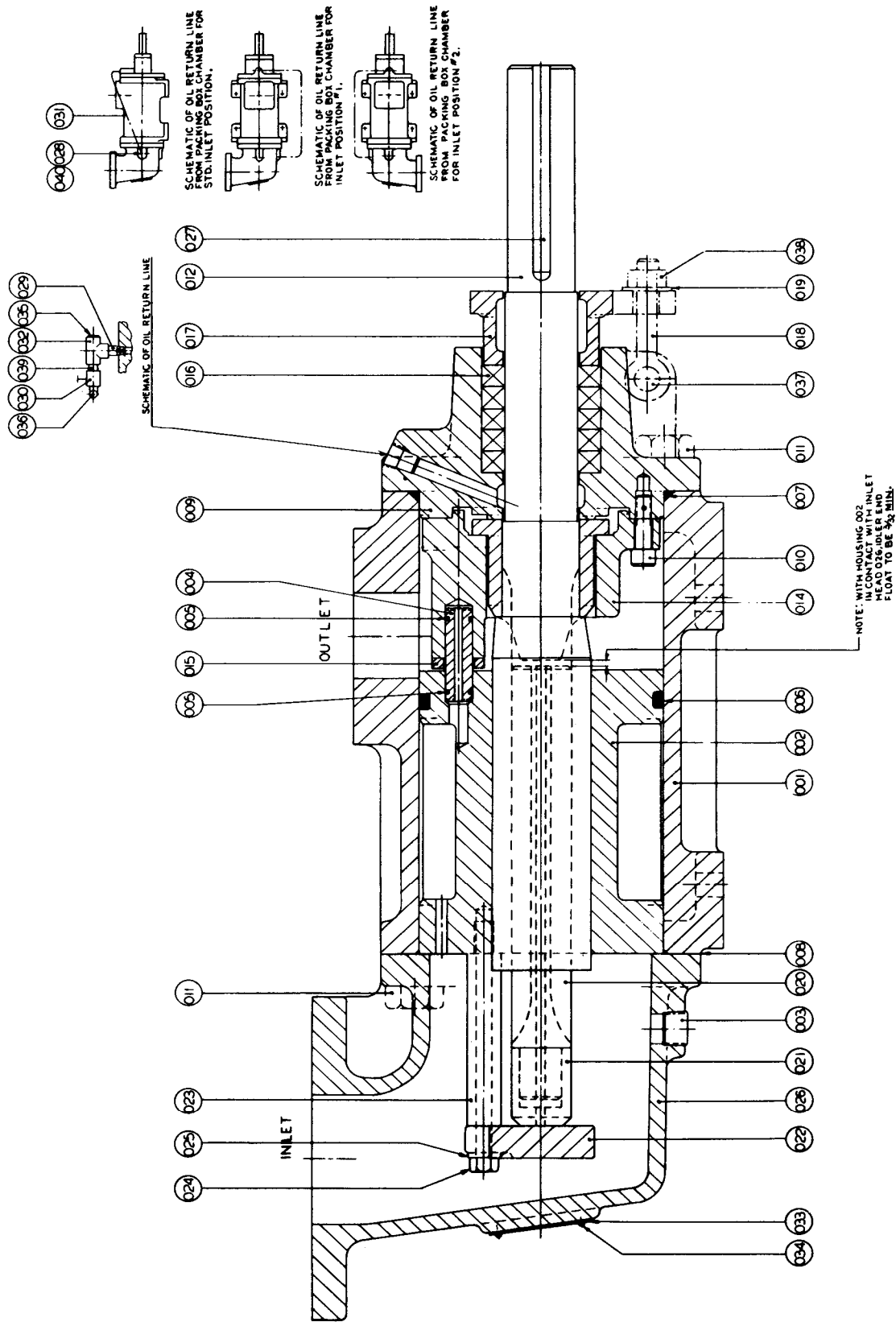

Note: Idler Cups (20) not required on some designs.

Figure 24. Rotor Size 218 and 250



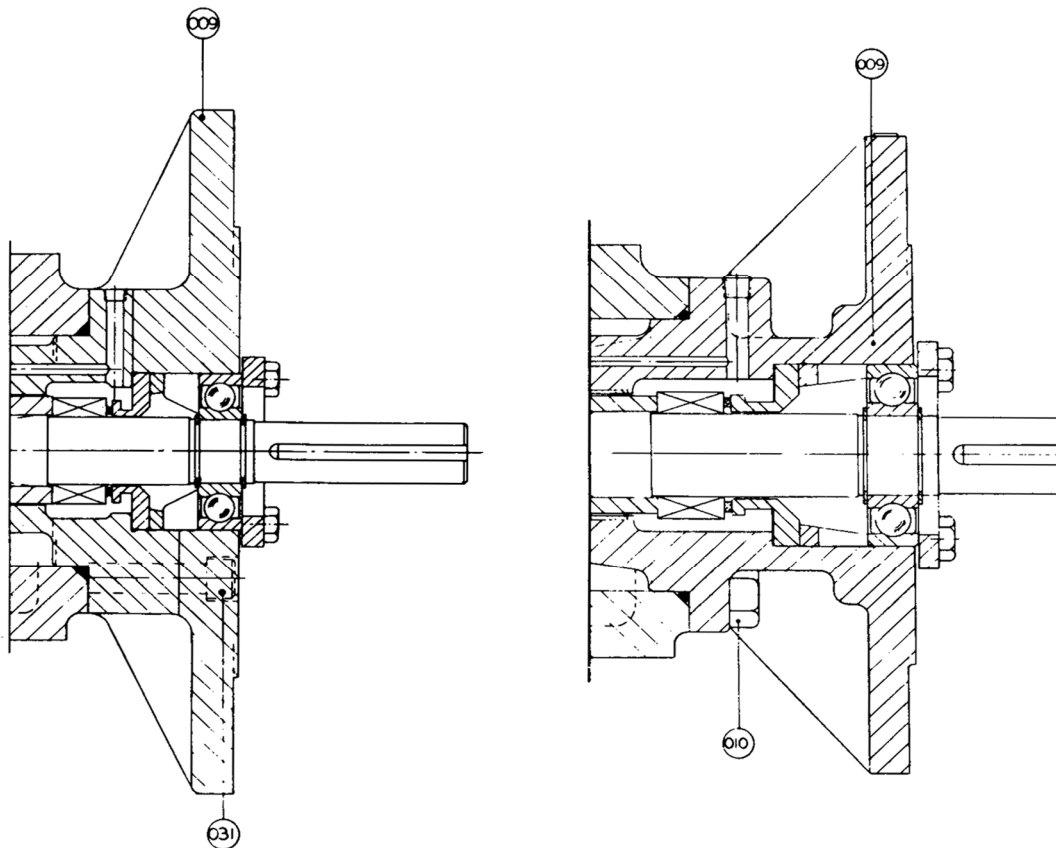

Construction A.  
Rotor Size 187

Construction B.  
Rotor Sizes 216 and 250

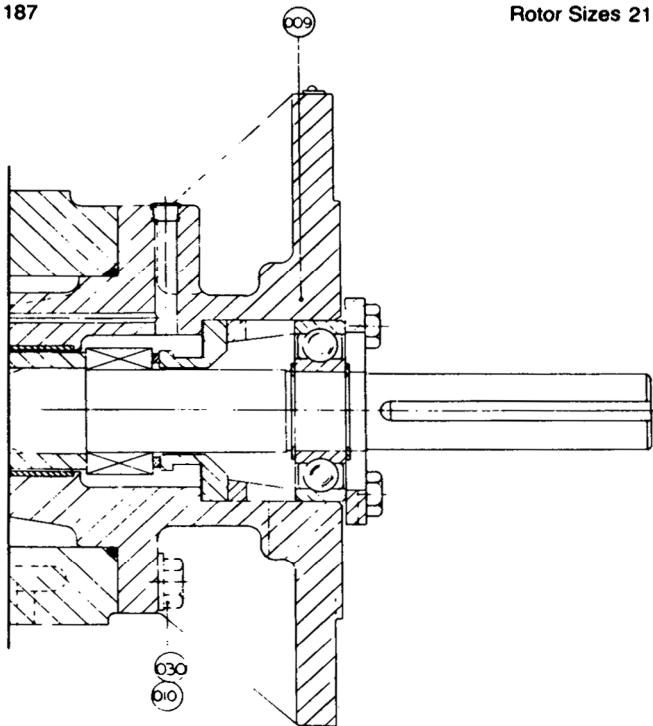

Construction C.  
Rotor Sizes 312 and 350

**Figure 25. Special Inboard Cover Construction**

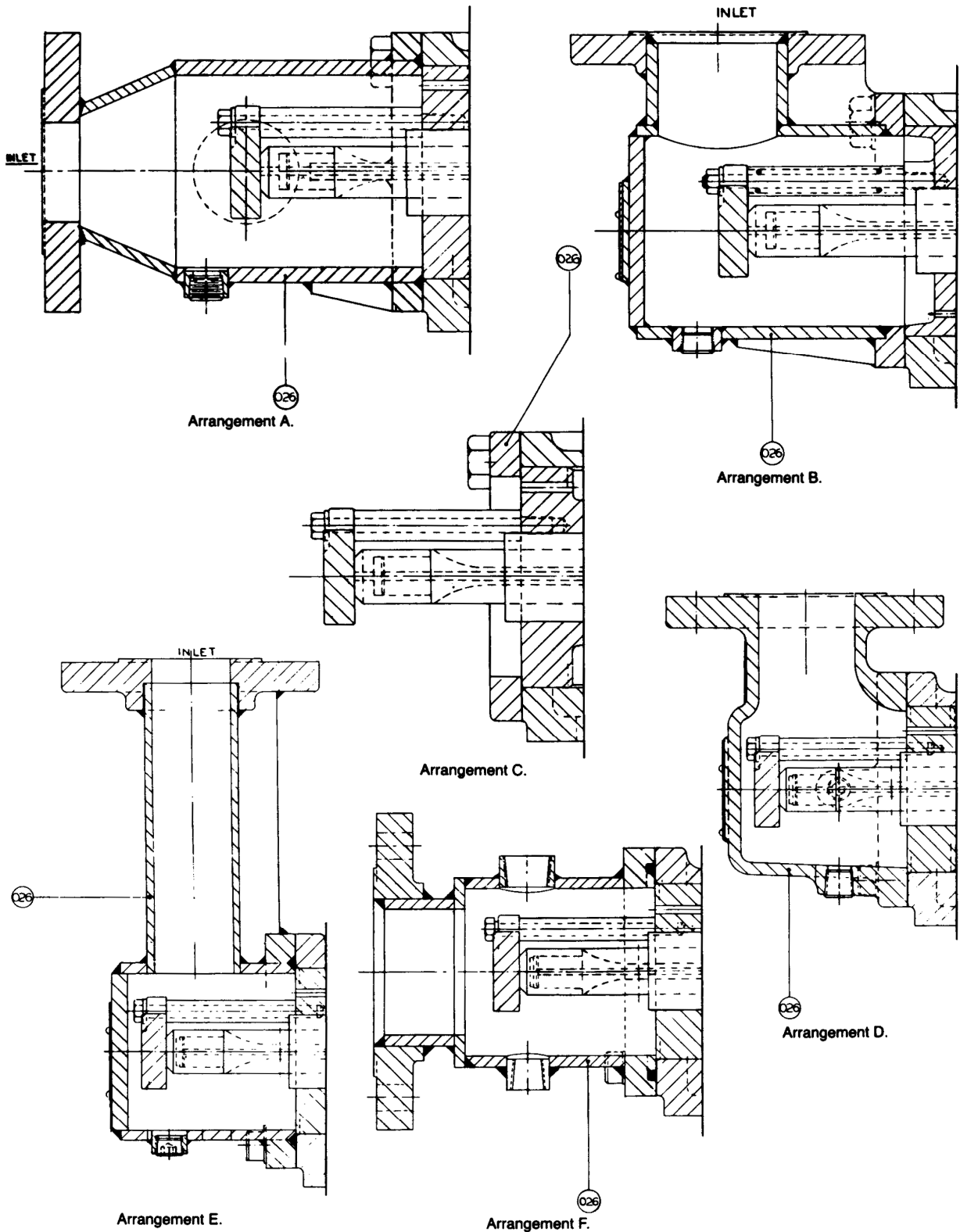

**Figure 26. Special Inlet Head Arrangements  
(continued on next page)**

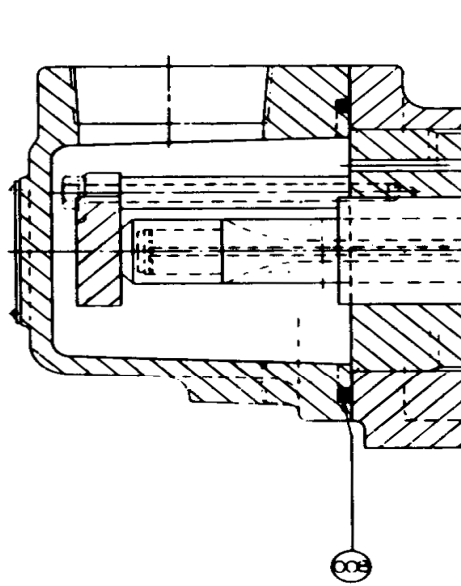

**Inlet Head with O-ring  
Arrangement G**

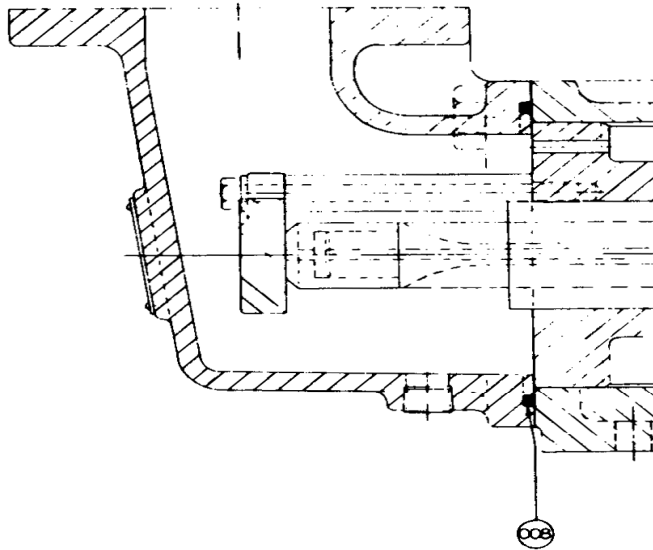

**Inlet Head with O-ring  
Arrangement H**

**Figure 26. Special Inlet Head Arrangements  
(continued from previous page)**

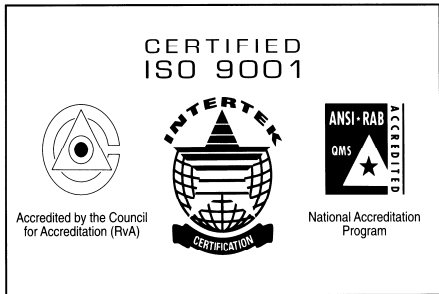

**CIRCOR**

1710 Airport Road  
PO Box 5020  
Monroe, NC USA  
28111.5020

*Tel:* +1. 877.853.7867  
*Email:* [cc@circor.com](mailto:cc@circor.com)  
*Web:* [www.circorpt.com](http://www.circorpt.com)

