



**INSTRUCTIONS and PARTS LIST**

**SERIES A324A  
(ROTOR SIZES 162-412)**

**WARNING**

**READ CA-1 AND THIS INSTRUCTION MANUAL BEFORE  
INSTALLATION, OPERATION, OR MAINTENANCE**

This manual now is  
identified as part no.  
SRM00037

**INSTRUCTIONS A324A (R-4)**

## ORDERING INSTRUCTIONS

All correspondence pertaining to renewal parts for the equipment must refer to the instruction book number and should be addressed to the nearest IMP Pump Division Sales Office or representative. See addresses of sales offices listed above.

The handling of renewal orders will be greatly facilitated if the following directions are carefully observed.

1. Give the number of the instruction book.
2. Give the serial number of the machine for which part is desired. This number appears on the nameplate.
3. Designate the desired part of by the number and name as listed in this instruction book.

**For Example:**

Instruction Book No. ....A324AS-325  
Serial Number .....505629  
Part Number and Name .....063, Power Rotor

## FOREWARD

The instructions given herein cover generally the operation and maintenance of subject equipment. Should any questions arise which may not be answered specifically by these instructions, they should be referred to IMO Pump Division for further detailed information and technical assistance. Customer Service phone 704-289-6511, Ext. 343, 349 or 358.

This manual cannot possibly cover every situation connected with the operation, adjustment, inspection, test overhaul and maintenance of the equipment furnished. Every effort is made to prepare the text of the manual so that engineering and design data is transformed into the most easily understood wording. IMO Pump Division, in furnishing this equipment and manual, must presume that the operating and maintenance personnel assigned thereto have sufficient technical knowledge and experience to apply sound safety and operational practices which may not be otherwise covered herein.

In application where IMO Pump Division furnished equipment is to be integrated with a process or other machinery, these instructions should be thoroughly reviewed to determine the proper integration of the equipment into the overall plant operational procedures. On critical or dangerous equipment, provide suitable safety and emergency systems to protect personnel and property from injury due to pump malfunction. If pump handles flammable, toxic, corrosive or explosive fluids, provide for safety in the event of pump leakage or malfunction.

If the installation, operation and maintenance instructions are not correctly and strictly followed and observed, serious damage to the pump could result. IMP Pump Division cannot accept responsibility for unsatisfactory performance or damage resulting from failure to comply with instructions.

## MAINTENANCE

### SECTION 1 (162-250 sizes)

**DISASSEMBLY** - Disconnect and remove shaft coupling. Remove outboard end cover (015). Pull the rotor set, power (013) and idler rotors (010). The rotors and housing bores may now be inspected. If bushing (018) is to be replaced, remove stop in (023) and remove bushing (018) from inboard cover (017).

In order to remove the rotor housings, remove pipe plugs (007) and housing stop pins (011). Stop pins are removed by using bolt and nut in tapped hole in top of pin. Note that stop pins should have one or two punch marks with a corresponding mark on the boss. If these marks are not present be sure to put them on before removing and observe carefully when reassembling. Disconnect tubing (037) and remove packing box end cover (017). Remove housings from their respective ends of the pump. Do not disturb adjusting screw settings unless new housings are to be installed. Spacer ring (012) can be removed from either end but it is seldom necessary.

**REASSEMBLY** - Before reassembling the pump, clean and inspect all parts. Replace all worn and damaged parts. All gaskets disturbed during disassembly should be replaced. Coat all rotating with light lubricating oil to aid reassembly. **DO NOT USE GREASE.**

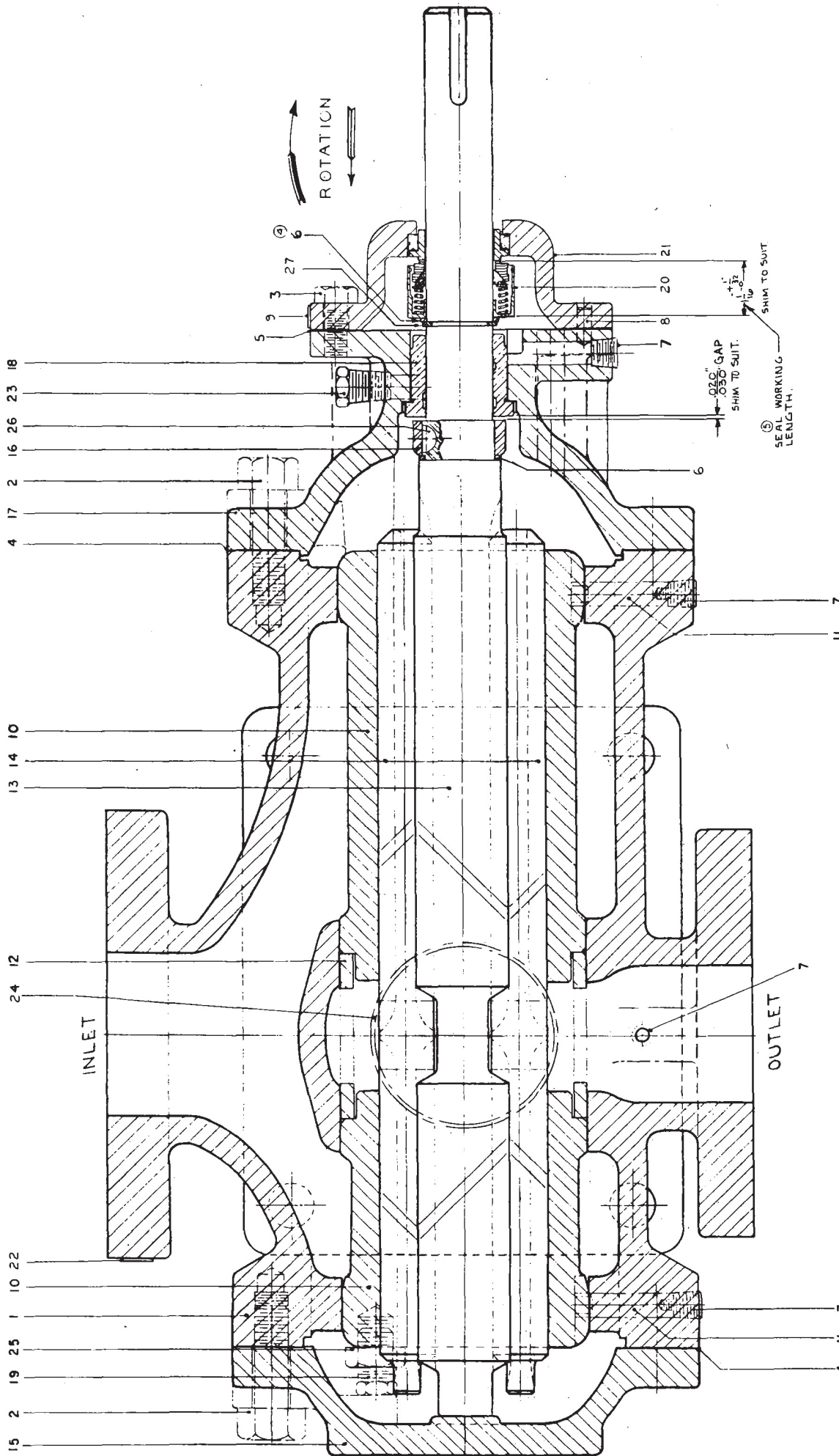
When replacing rotor housings (010) insert inboard housing first with stop pin slot properly positioned. Replace housing stop pin (011) taking care to use proper marked pin. Insert pipe plug (007) on top of pin. Install outboard housing using rotors as aligning bars. Replace other stop pin and pipe plug. If new housings are used stop pins must be checked carefully. These pins are fitted at assembly and it will probably be necessary to fit new pins to insure snug fit with new housings. Lubricate bushing (018) with oil, align bushing slot with tapped hole in inboard cover (017) where stop pin (023) will be installed. Carefully install bushing (018) into inboard cover (017). Using the inboard cover (017) as a fixture, carefully position the inboard cover (017) in a vice or other solid holding device on a drill press so that the tapped hole in the inboard cover is oriented in a vertical position. **NOTE:** Use caution to prevent damage to the threads of the tapped hole during this step. Run a 7/16" drill through the tapped hole and drill completely through one side of bushing (018). Carefully deburr the bushing bore where the drill comes through install stop pin (023) in inboard cover (017). Check and verify that the stop pin (023) fully engages the bushing (018) in the hole just drilled, but does not extend into the bushing bore. If stop in (023) extends into the bushing (018) bore, remove the pin and shorten as required. The stop pin (023) end face should be approximately 1/64" recessed from the bushing (018) bore. Next, loosen packing gland (028) slightly, install new gasket (004), and replace packing box end cover (017). Housing adjusting screws (019) at outboard end should be set by measuring distance from mounting face of end cover (015) to face of machine pad. Add to this figure 60% of the thickness of the gasket to be used. Transfer reading to head of adjusting screw and face of pump case. Check contact of adjusting screws with bluing to be sure desired pressure has been obtained. **CAUTION:** Do not have over .003" pressure on these screws to avoid distortion of rotor housing bores.

After pump is reassembled make sure tubing (037) is connected and that packing gland (028) is properly set. See instruction book CA-1 on proper setting of packing gland (8 to 10 drops per minute is required leakage). Check that rotors turn freely and that original alignment of pump and driver is re-established before closing the coupling.

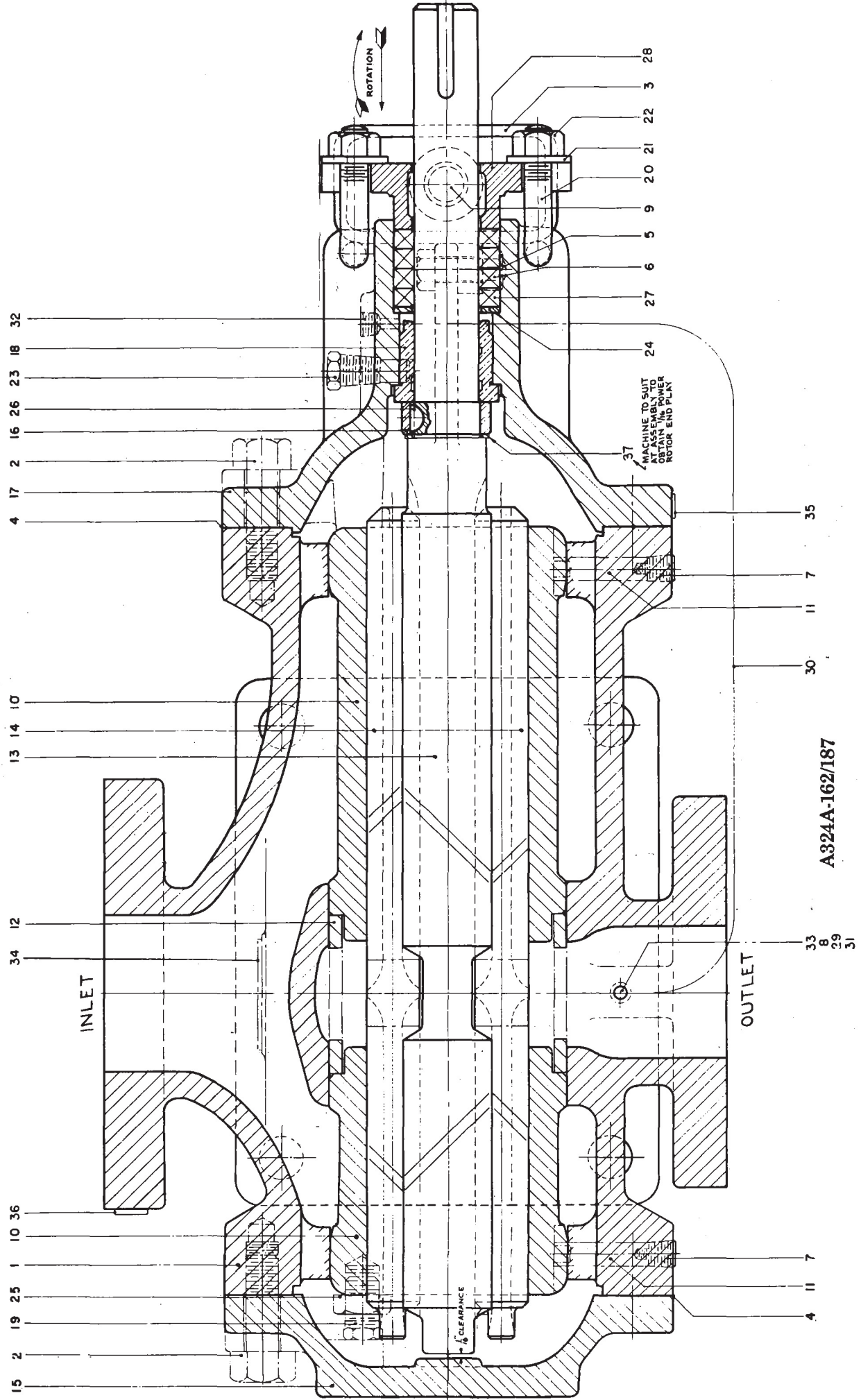
## PARTS LIST

A324A, AS, AA 162 - 250

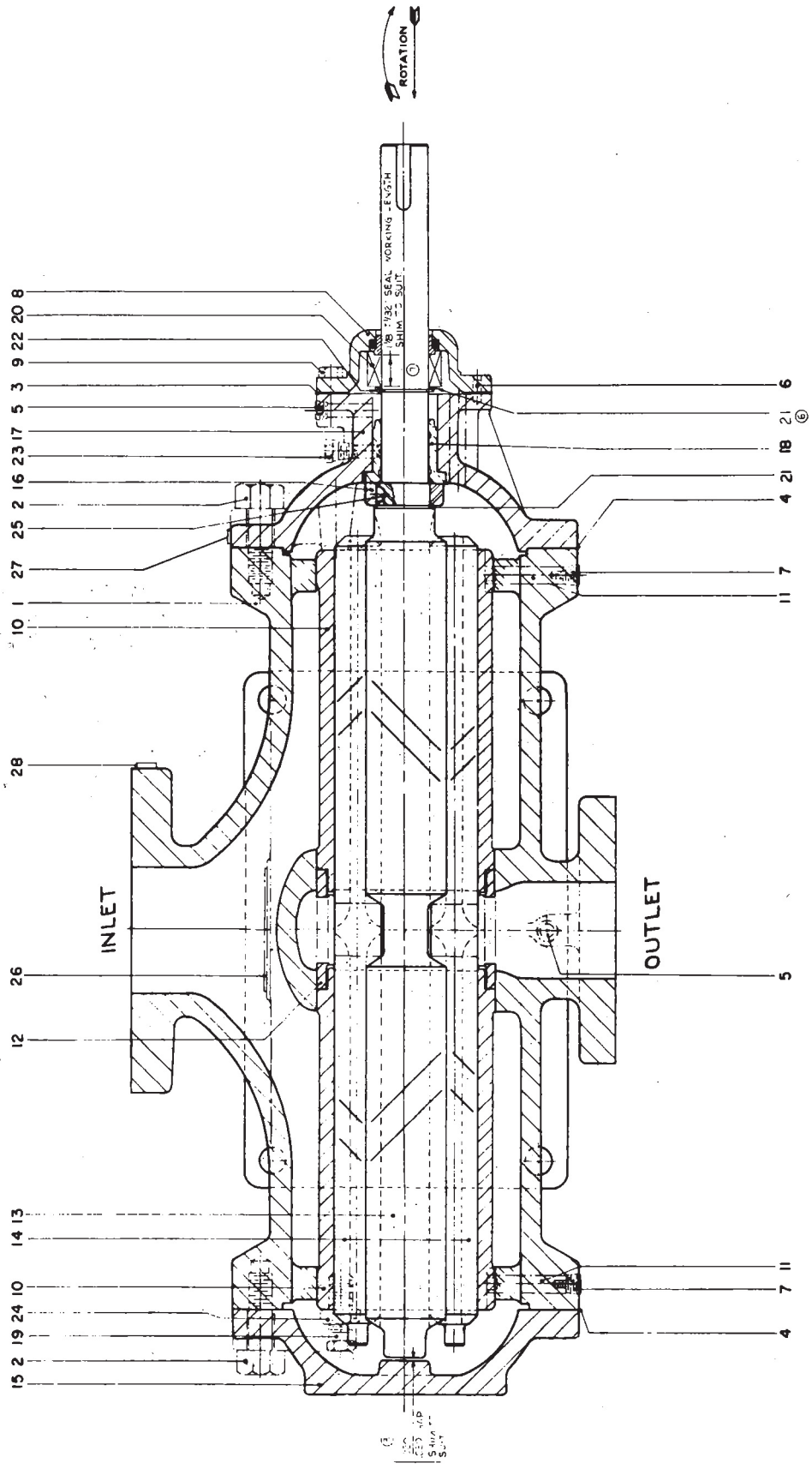
No.	Name	No.	Name
001	Case	021	Washer (Packing Design)
002	Bolt	021	Shim (Seal Design 231/250)
003	Drip Cup (Packing Design)	021	Seal Cover
003	Gasket (Seal Design 231/250)	022	Nut (Packing Design )
003	Bolt (Seal Design 162/187)	022	Snap Ring (Seal Design 231/250)
004	Gasket	023	Stop Pin
005	Gasket (Seal Design 162/187)	024	Washer (Packing Design)
006	Shim (Seal Design 162/187)	024	Jam Nut (231/250)
007	Pipe Plug	025	Jam Nut (162/187)
008	Needle Valve	025	Key (231/250)
008	Seal Cover (231/250)	026	Key (162/187)
009	Bolt (Seal Design 231/250)	027	Packing
010	Housing	027	Snap Ring (Seal Design 162/187)
011	Housing Stop Pin	028	Packing Gland
012	Spacer Ring	029	Tubing
013	Power Rotor	030	Nameplate
014	Idle Rotor	031	Nameplate
015	End Cover - Outboard	032	Nameplate
016	Thrust Collar	033	Rivet
017	Front Cover	034	Coupling
018	Bushing	035	Ermeto Fitting
019	Adjusting Screw	036	Ermeto Fitting
020	Seal	037	Shim
020	Gland Bolt	038	Nipple



A324AS/AA-162/187

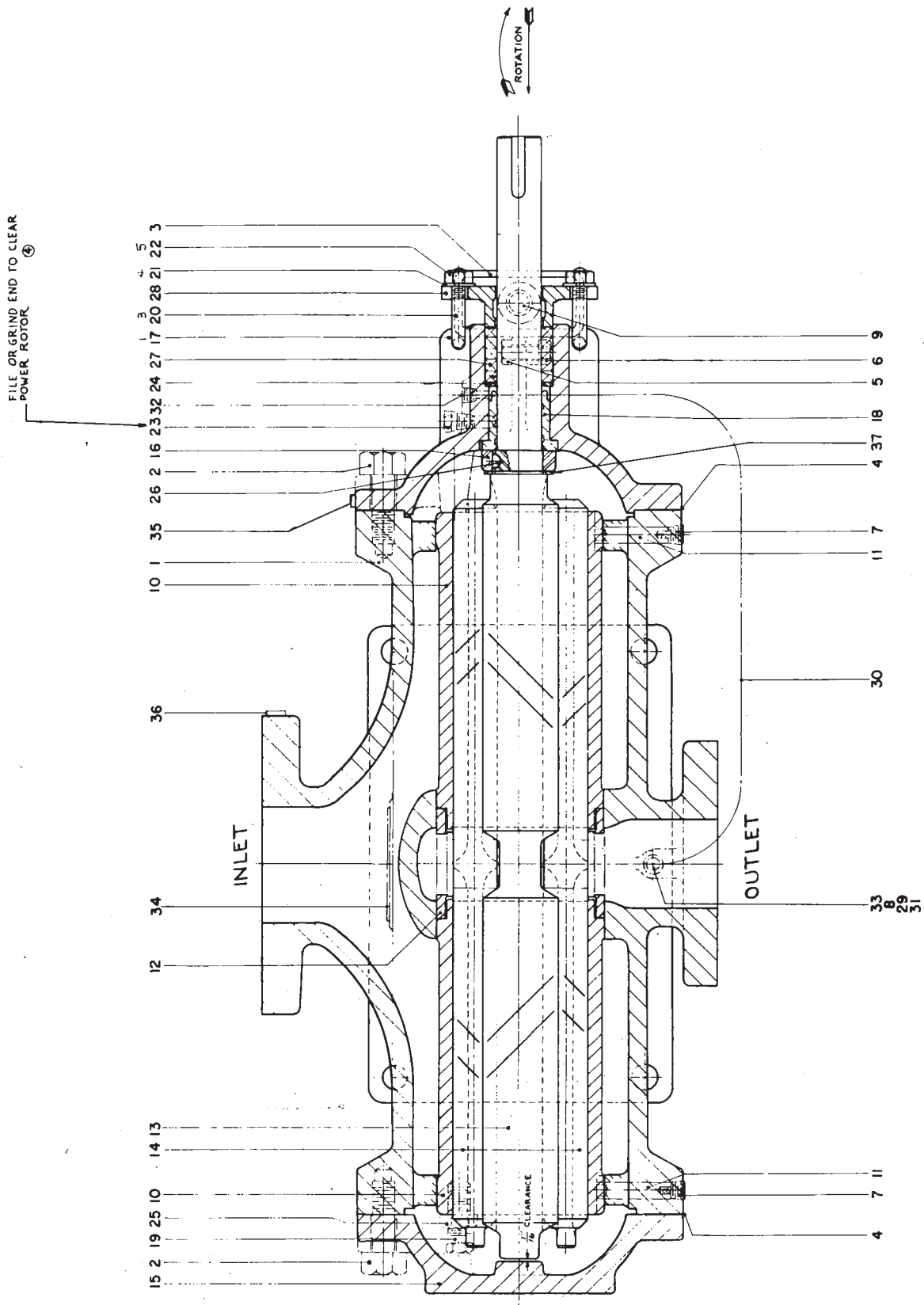


A324A-162/187



A324AS/AA-231/250

FILE OR GRIND END TO CLEAR  
POWER ROTOR ④



A324A-231/250



## **SECTION 2**

### **(275-300 sizes)**

**DISASSEMBLY** - Remove checknut (029) and shaft coupling. Remove packing gland (021). Remove outboard end cover (015) together with bushing (025) and thrust plate (032). Remove power rotor (013) and idler rotors (014) together from outboard end. Rotors and housing bores may now be inspected. If it is necessary to remove housings proceed as follows.

Remove pipe plugs (012) and rotor housing stop pins (011). Stop pins are removed by using bolt and nut in tapped hole in top of pin. Refer to Section 1 for instructions regarding marking of stop pins, if not already marked, before removal. Disconnect seal piping and remove packing box end cover (017). Remove rotor housings (010) from their respective ends of the pump. Do not disturb setting of housing adjusting screws (038) unless new housings are to be installed.

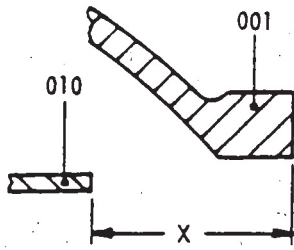
**REASSEMBLY** - Before reassembling the pump, clean and inspect all parts. Replace all worn or damaged parts. All gaskets disturbed during disassembly should be replaced. Coat all rotating parts with light lubricating oil to aid reassembly. **DO NOT USE GREASE.**

Replace rotor housings (010). Follow procedure outlined in Section 1 except that socket head pipe plug which goes on top of stop pin will be (012).

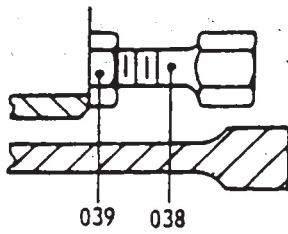
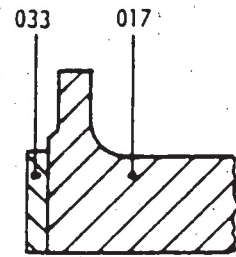
Housing adjusting screws should be set as follows: Set inboard end adjusting screws as shown in Fig. 1. Install new gasket (007) and replace packing box end cover (017) making sure adjusting screws are set firmly against thrust block (033). Proceed as shown in Fig. 2 and set outboard adjusting screws. Install new gasket (007) and install end cover (015). When end cover is pulled up tight, the adjusting screws fit snugly against thrust block (032). **CAUTION:** Do not have over .003" pressure on these screws to avoid distortion of rotor housing bores.

Adjust end play of power rotor within limits shown on assembly drawings (.030" with mechanical seal; .060" to .090" for packing type). End play is adjusted by use of laminated shim (041) which is on outboard end of power rotor.

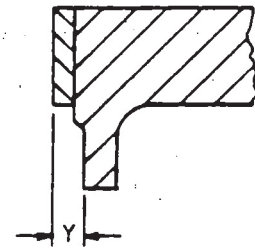
After pump is reassembled make sure seal piping is connected and that packing gland (021) is properly set. See instruction book CA-1 on properly setting packing gland. Check that rotors turn freely and that original alignment of pump and driver is re-established before closing the coupling.



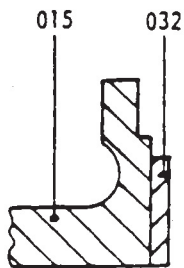
Subtract "Y" from "X". Add 60% of thickness of gasket to be used. Set adj. screw (038) to this figure. Use bluing or fuse wire to check contact.



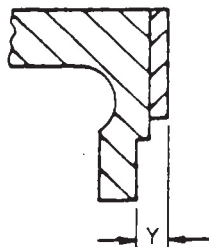
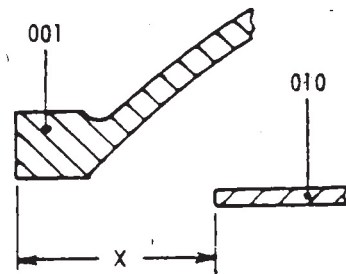
**INBOARD END**



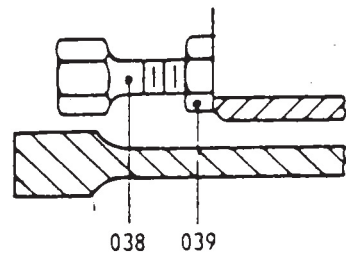
**FIG. 1**



Make sure housing assembly is snug against inboard end. Subtract "Y" from "X". Add 60% of thickness of gasket to be used. Set adj. screw (038) to this figure. Use bluing or fuse wire to check contact.



**OUTBOARD END**



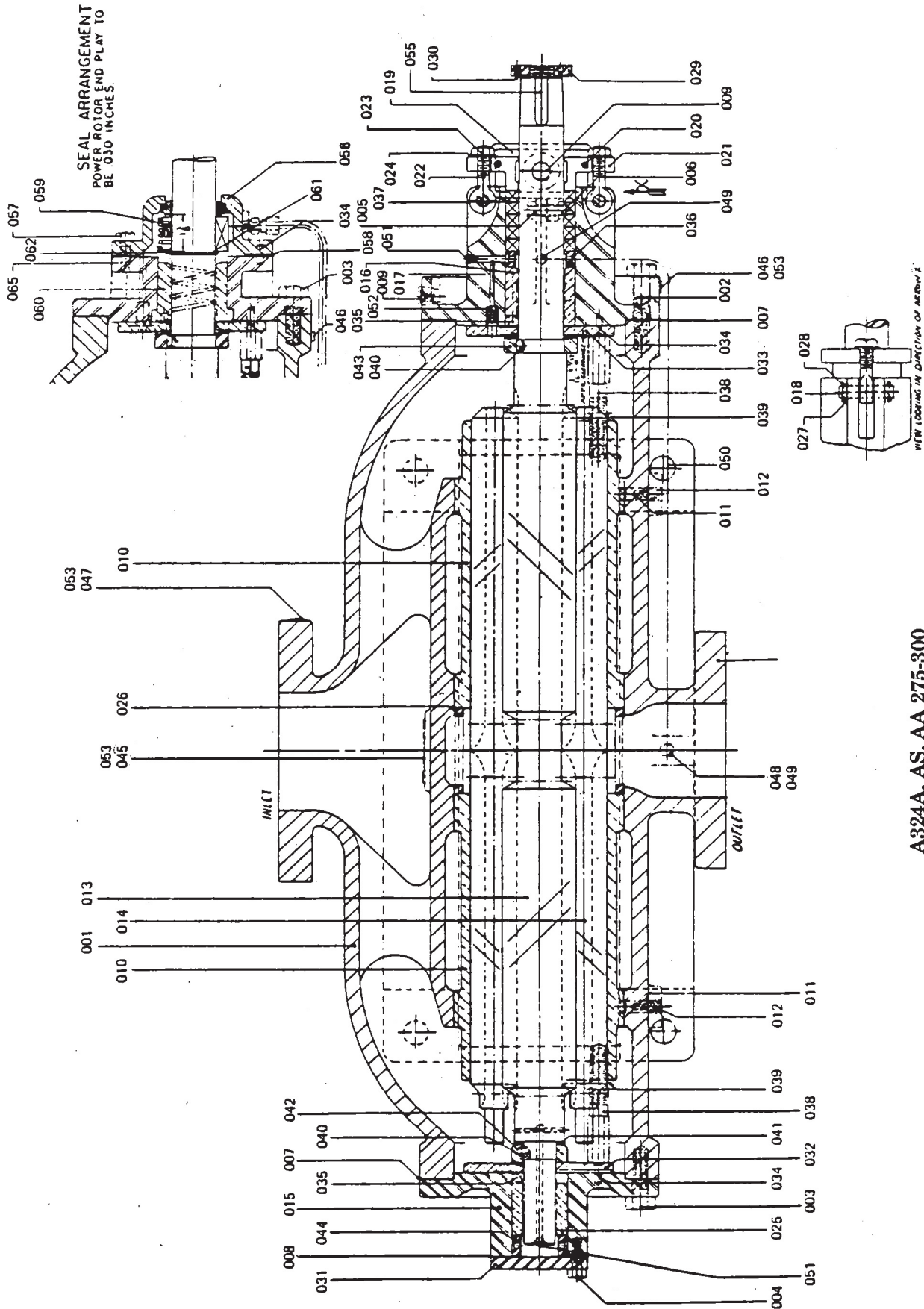
**FIG. 2**

**PARTS LIST  
SECTION 2  
A324A, AS & AA 275-300**

No.	Name	No.	Name
001	Pump Case	028	Cotter Pin
002	Hex Head Bolt	029	Check Nut
003	Hex Head Bolt	030	Set Screw
004	Hex Head Bolt	031	End Cover
005	Hex Head Bolt	032	Thrust Block
006	Nut	033	Thrust Block
007	Gasket	034	Dowel Pin
008	Gasket	035	Pin
009	Socket Head Pipe Plug	036	Lantern Ring
010	Rotor Housing	037	Packing
011	Rotor Housing Stop Pin	038	Adjusting Screw
012	Socket Head Pipe Plug	039	Jam Nut
013	Power Rotor	040	Woodruff Key
014	Idler Rotor	041	Laminated Shim
015	End Cover - Outboard	042	Thrust Collar
016	Bushing	043	Thrust Collar
017	Packing Box End Cover	044	Lantern Ring
018	Gland Bolt Pin	045	Name Plate
019	Drip Cup	046	Name Plate
020	Fillister Head Cap Screw	047	Name Plate
021	Packing Gland	048	Needle Valve
022	Gland Bolt	049	Ermeto Fitting
023	Nut	050	Tubing
024	Washer	051	Pipe Plug
025	Bushing	052	Relief Valve
026	Spacer Ring	053	Rivet
027	Washer	055	Key

**PARTS FOR AS TYPE PUMP ONLY**

056	End Cover
057	Hex Head Bolt
058	Gasket
059	Mechanical Seal
060	Bushing
061	Snap Ring
062	Laminated Shim
065	End Cover - Inboard



A324A, AS, AA 275-300

### SECTION 3 (325-412 sizes)

**DISASSEMBLY** - Remove checknut (042) and shaft coupling. Remove packing gland (026). Remove outboard end cover (015) together with bearing (016). Remove power rotor (013) and idler rotors (014) from outboard end. Rotors and housing bores may now be inspected. If it is necessary to remove housings proceed as follows.

Remove pipe plug (009) and rotor housing stop pin (011). Stop pins are removed by using bolt and nut in tapped hole in top of pin. Refer to Section 1 for information regarding marking of stop pins, if not already marked, before removal. Disconnect seal piping and remove packing box end cover (017). Remove rotor housings (010) from their respective ends of the pump. Do not disturb setting of housing adjusting screws unless new housings are to be installed.

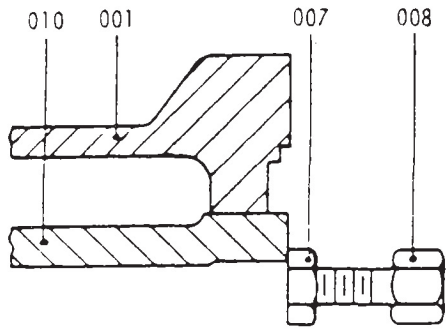
**REASSEMBLY** - Before reassembling the pump, clean and inspect all parts. Replace all worn or damaged parts. All gaskets disturbed during disassembly should be replaced. Coat all rotating parts with light lubricating oil to aid reassembly. **DO NOT USE GREASE.**

Replace rotor housing (010). Follow procedures outlined in Section 1 except that socket head pipe plug which goes on top of stop pin will be (009).

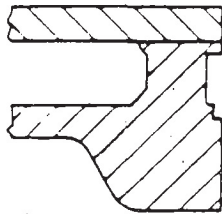
Housing adjusting screws should be set as follows: Set inboard end adjusting screws as shown in Fig. 3. Install new gasket (005) and replace packing box end cover (017) making sure adjusting screws are set firmly against bearing (018). Proceed as shown in Fig. 4 and set outboard adjusting screws. Install new gasket (005) and install end cover (015). When end cover is pulled up tight, the adjusting screws should fit snugly against bearing (016). **CAUTION:** Do not have over .003" pressure on these screws to avoid distortion of rotor housing bores.

Adjust end play of power rotor within limits shown on assembly drawing (.030" with mechanical seal: .060" to .090" for packing type). End play is adjusted by use of laminated shim (020) which is on outboard end of power rotor.

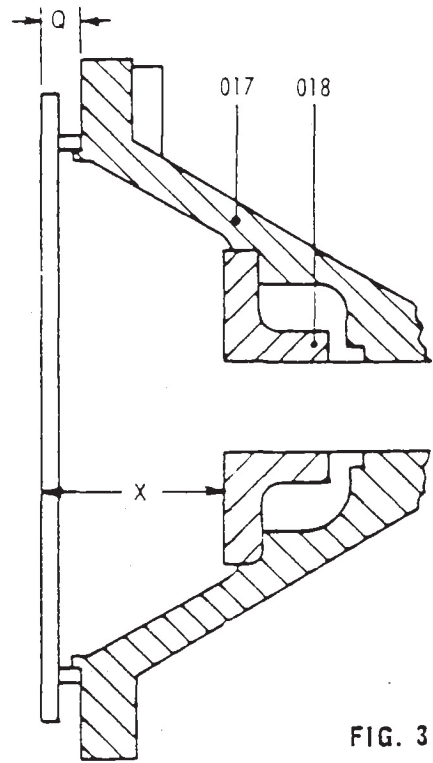
After pump is reassembled make sure seal piping is connected and that packing gland (026) is properly set. See instruction book CA-1 on properly setting packing gland. Check that rotors turn freely and that original alignment of pump and driver is re-established before closing the coupling.



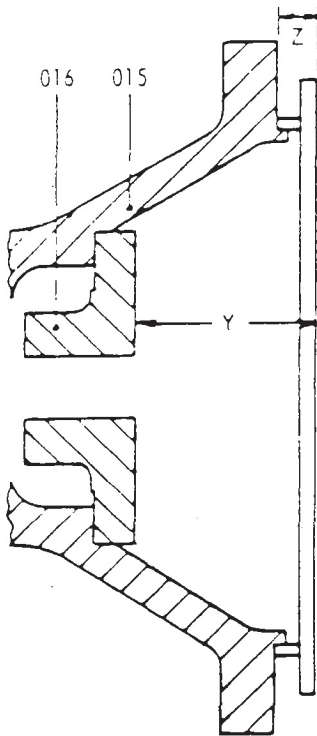
Set face of housing (010) flush with end of case (001). Subtract "Q" from "X". Add 60% of thickness of gasket to be used. Set adj. screw (008) to this figure. Use bluing or fuse wire to check contact.



**INBOARD END**

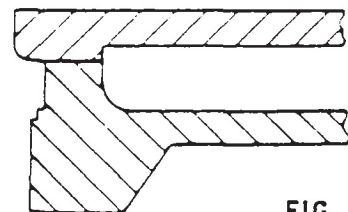
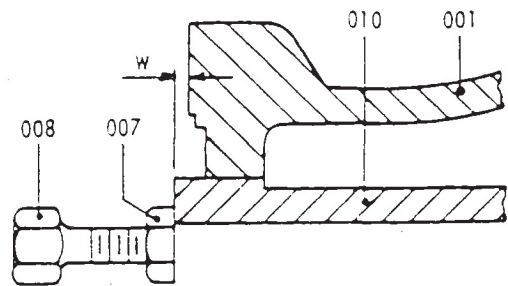


**FIG. 3**



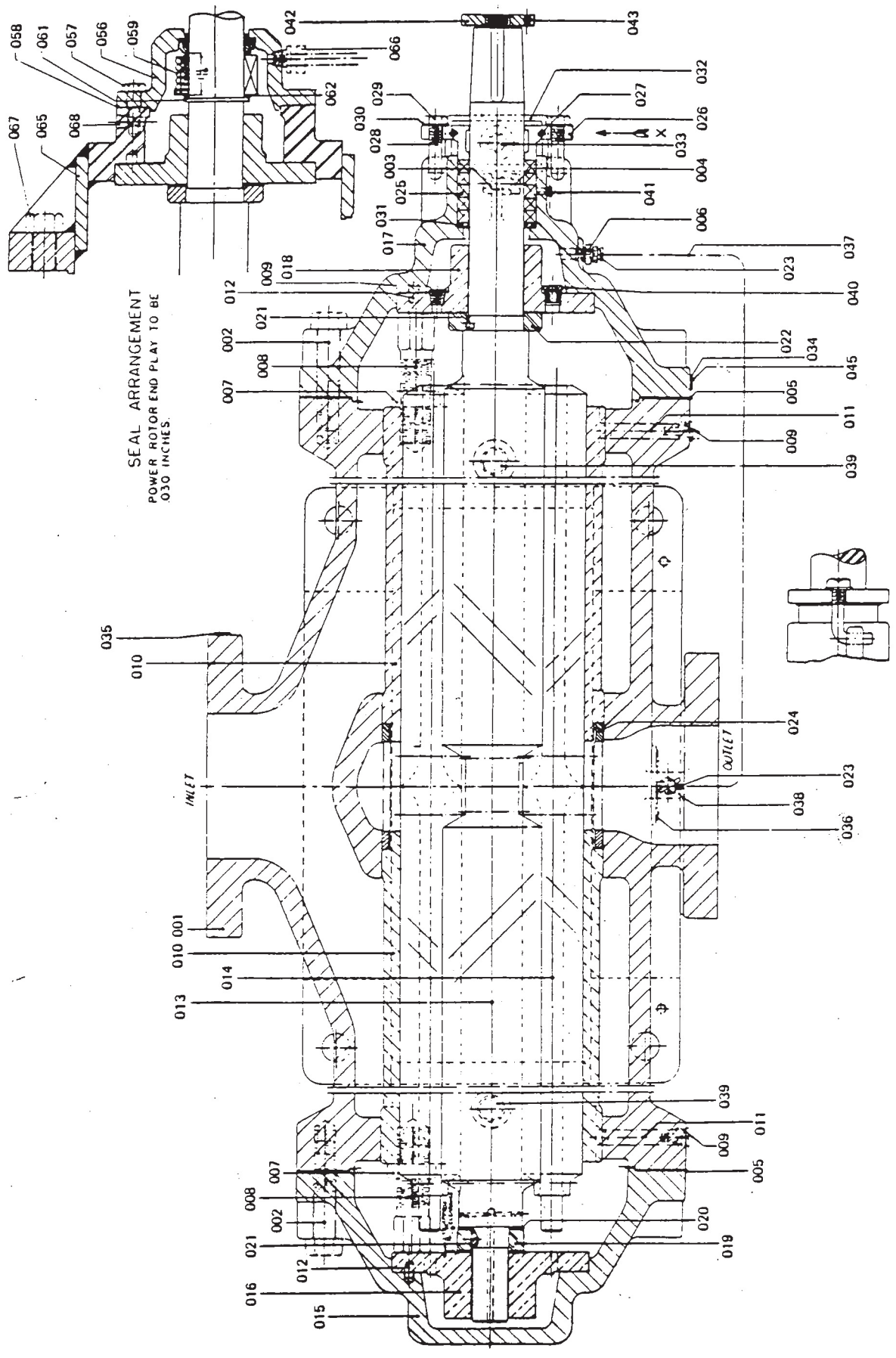
Make sure housing assembly is snug against inboard end. Subtract "Z" + "W" from "Y". Add 60% of thickness of gasket to be used. Set adj. screw (008) to this figure. Use bluing or fuse wire to check contact.

**OUTBOARD END**



**FIG. 4**



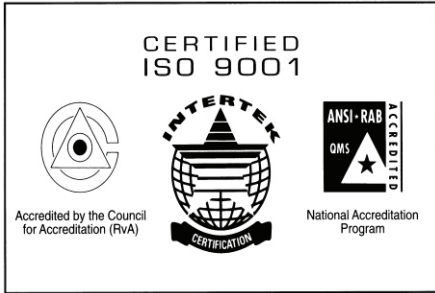


SEAL ARRANGEMENT  
 POWER ROTOR END PLAY TO BE  
 0.30 INCHES.

VIEW LOOKING IN DIRECTION  
 OF ARROW "X"

A324A, AA, AS, 325-412





**CIRCOR**

1710 Airport Road  
PO Box 5020  
Monroe, NC USA  
28111.5020

Tel: +1. 877.853.7867

Email: [cc@circor.com](mailto:cc@circor.com)

Web: [www.circorpt.com](http://www.circorpt.com)

